

Vitocal 350-G

Type BW/BWS 351.B20 to B42

Heat pump with electric drive, 1 and 2-stage

- Brine/water heat pump: 20.5 to 84.6 kW
- With conversion kit to water/water heat pump: 25.4 to 104.6 kW



VITOCAL 350-G



Safety instructions

 Please follow these safety instructions closely to prevent accidents and material losses.

Safety instructions explained

 **Danger**
This symbol warns against the risk of injury.

 **Please note**
This symbol warns against the risk of material losses and environmental pollution.

Note
Details identified by the word "Note" contain additional information.

Target group

These instructions are exclusively intended for authorised contractors.

- Work on the refrigerant circuit may only be carried out by authorised refrigeration engineers.
- Work on electrical equipment must only be carried out by a qualified electrician.
- The system must be commissioned by the system installer or a qualified person authorised by the installer.

Regulations to be observed

- National installation regulations
- Statutory regulations for the prevention of accidents
- Statutory regulations for environmental protection
- Codes of practice of the relevant trade associations
- Relevant country-specific safety regulations

Safety instructions (cont.)**Safety instructions for working on the system****Working on the system**

- Isolate the system from the power supply, e.g. by removing the separate fuse or by means of a mains isolator, and check that it is no longer live.

Note

In addition to the control circuit there may be several power circuits.

**Danger**

Contact with live components can result in severe injuries. Some components on PCBs remain live even after the power supply has been switched off.

Prior to removing covers from the appliances, wait at least 4 minutes until the voltage has completely dropped out.

- Safeguard the system against reconnection.
- Wear suitable personal protective equipment when carrying out any work.

**Danger**

Hot surfaces and fluids can lead to burns or scalding.

- Before maintenance and service work, switch OFF the appliance and let it cool down.
- Never touch hot surfaces on the appliance, fittings or pipework.

**Danger**

Risk of fire: Electrostatic discharge can cause sparks which may be ignited by escaping, flammable refrigerant (R32).

Prior to commencing work, touch earthed objects such as heating or water pipes to discharge static loads.

**Please note**

Electronic assemblies can be damaged by electrostatic discharge. Prior to commencing work, touch earthed objects such as heating or water pipes to discharge static loads.

Work on the refrigerant circuit

Refrigerants are air displacing, colourless, odourless gases.

- R32 forms flammable mixtures with air.
- R410A is not flammable.

**Danger**

Direct contact with liquid and gaseous refrigerant can cause serious damage to health.

- Avoid direct contact with liquid and gaseous refrigerant.
- Wear personal protective equipment when handling liquid and gaseous refrigerant.

**Danger**

Unregulated escape of refrigerant in enclosed spaces can lead to breathing difficulties and suffocation.

- Never breathe in refrigerant vapours.
- Ensure adequate ventilation in enclosed spaces.

Perform the following measures before beginning work on the refrigerant circuit:

- Check the refrigerant circuit for leaks.
- Ensure very good ventilation especially in the floor area and sustain this for the duration of the work.
- Inform all persons in the vicinity of the system about the type of work to be carried out.
- Secure the area surrounding the work area.

Safety instructions (cont.)

Further measures before starting work on the refrigerant circuit with flammable refrigerants (R32):

- Remove all flammable materials and ignition sources from the immediate vicinity of the heat pump.
- Before, during and after the work, check the surrounding area for escaping refrigerant using a suitable refrigerant detector.

This refrigerant detector must not generate any sparks and must be suitably sealed.

- A CO₂ or powder extinguisher must be to hand in the following cases:
 - Refrigerant is being topped up.
 - When soldering or welding work is being carried out.
- Display signs prohibiting smoking.

Danger

Damage to the refrigerant circuit can cause refrigerant to enter the hydraulic system. This can cause serious damage to health.

After completion of the work, professionally vent the hydraulic system on the primary and secondary sides.

Repair work

Please note

Repairing components that fulfil a safety function can compromise the safe operation of the system. Replace faulty components only with genuine Viessmann spare parts.

Auxiliary components, spare and wearing parts

Please note

Spare and wearing parts that have not been tested together with the system can compromise its function. Installing non-authorised components and making non-approved modifications or conversions can compromise safety and may invalidate our warranty.

For replacements, use only original spare parts supplied or approved by Viessmann.

Safety instructions for operating the system

What to do if water escapes from the appliance

Danger

If water escapes from the appliance there is a risk of electrocution. Switch OFF the heating system at the external isolator (e.g. fuse box, domestic distribution board).



Danger

If water escapes from the appliance there is a risk of scalding. Never touch hot heating water.

Index

1. Information	Disposal of packaging	7
	Symbols	7
	Intended use	7
	Product information	8
	■ Type BW 351.B	8
	■ Type BWS 351.B (heat pump stage 2)	8
	■ System examples	9
	■ Spare parts lists	9
2. Preparing for installation	Requirements regarding on-site connections	10
	■ 1-stage: Type BW 351.B	10
	■ 2-stage: Type BW 351.B + BWS 351.B	11
	Siting and transport requirements	11
	■ Transport	11
	■ Installation room requirements	12
3. Installation sequence	Positioning the heat pump	14
	■ Levelling the heat pump	14
	■ Removing the transport brackets	15
	■ Removing the top panel	16
	Making the hydraulic connections	16
	■ Connecting the primary circuit	17
	■ Connecting the secondary circuit	17
	Electrical connection	18
	■ Preparing the electrical connections	18
	■ Installing the programming unit (type BW 351.B)	19
	■ Routing cables to the wiring chamber	20
	■ Making the electrical connection of heat pump stage 1 (type BW 351.B) and stage 2 (type BWS 351.B)	22
	■ Overview of electrical connections in the heat pump control unit (type BW 351.B)	23
	■ Main PCB (function components 230 V~)	23
	■ Expansion PCB on main PCB (230 V~ components)	27
	■ Cross connect PCB (message and safety connections)	31
	■ Controller and sensor PCB (sensors)	33
	■ Connecting the primary circuit flow/return temperature sensor, 2-stage heat pump	34
	■ Swimming pool heating	35
	Power supply	35
	■ Heat pump control unit power supply 230 V~	36
	■ Compressor power supply 400 V~	37
	■ Power supply with power-OFF: Without on-site load disconnect	37
	■ Power supply with power-OFF: With on-site load disconnect	39
	■ Mains power supply in conjunction with on-site power consumption	42
	■ Smart Grid	42
	■ Phase monitor (if installed)	44
	Make connections at terminals X3.8/X3.9	45
	Closing the heat pump	45
	Checking the diaphragm grommets	48
4. Commissioning, inspection, maintenance	Steps - commissioning, inspection and maintenance	49
5. Maintenance	Overview of wiring chamber	64
	Opening the casing door	64
	Overview of internal components	65
	Draining the heat pump on the primary/secondary side	66
	Checking the sensors	66
	■ Viessmann NTC 10 kΩ (blue marking)	67
	■ Viessmann Pt500A (green marking)	68









Index (cont.)

	Checking MCBs/fuses	68
	The appliance is too noisy	69
	Condensation and moisture in the heat pump module	69
	Removing the heat pump module	70
	Installing the heat pump module	72
6. Commissioning/service reports	Hydraulic parameter report	73
	Control parameter report	73
7. Specification	Specification for brine/water heat pumps	84
	Specification for water/water heat pumps	86
8. Appendix	Commissioning order	87
	Final decommissioning and disposal	87
9. Certificates	Declaration of conformity	88
10. Keyword index	89







Disposal of packaging

Please dispose of packaging waste in line with statutory regulations.

Symbols

Symbol	Meaning
	Reference to other document containing further information
	Step in a diagram: The numbers correspond to the order in which the steps are carried out.
	Warning of material losses and environmental pollution
	Live electrical area
	Pay particular attention.
	<ul style="list-style-type: none"> Component must audibly click into place. or Acoustic signal
	<ul style="list-style-type: none"> Fit new component. or In conjunction with a tool: Clean the surface.
	Dispose of component correctly.
	Dispose of component at a suitable collection point. Do not dispose of component in domestic waste.

The steps in connection with commissioning, inspection and maintenance are found in the "Commissioning, inspection and maintenance" section and identified as follows:

Symbol	Meaning
	Steps required during commissioning
	Not required during commissioning
	Steps required during inspection
	Not required during inspection
	Steps required during maintenance
	Not required during maintenance

Intended use

The appliance is only intended to be installed and operated in sealed unvented heating systems that comply with EN 12828, with due attention paid to the associated installation, service and operating instructions.

Depending on the version, the appliance can only be used for the following purposes:

- Central heating
- Central cooling
- DHW heating

The range of functions can be extended with additional components and accessories.

Intended use presupposes that a fixed installation in conjunction with permissible, system-specific components has been carried out.

Commercial or industrial usage for a purpose other than central heating/cooling or DHW heating shall be deemed inappropriate.

Intended use (cont.)

Incorrect usage or operation of the appliance (e.g. the appliance being opened by the system user) is prohibited and will result in an exclusion of liability. Incorrect usage also occurs if the components in the heating system are modified from their intended function.

Note

The appliance is intended exclusively for domestic or semi-domestic use, i.e. even users who have not had any instruction are able to operate the appliance safely.

Product information**Type BW 351.B****Design**

Vitocal 350-G, type BW 351.B are brine/water heat pumps for central heating, room cooling and DHW heating in mono mode or mono energetic systems. The refrigerant circuit has an electronic expansion valve (EEV) with an independent control circuit (refrigerant circuit controller). For central heating and DHW heating, an instantaneous heating water heater (on site) can also be controlled.

Output extension

The output of type BW 351.B can be supplemented with a heat pump stage 2 (type BWS 351.B).

Hydraulics

For type BW 351.B, high efficiency circulation pumps for the primary and secondary circuits and a high efficiency circulation pump for DHW heating are available as accessories.

Conversion to a water/water heat pump

The Vitocal 350-G brine/water heat pump, type BW 351.B, becomes a water/water heat pump in conjunction with the conversion kit (accessories). A separate well circuit provides the primary circuit with heating energy via a separating heat exchanger (accessories). The components of the well circuit and primary circuit are controlled by the heat pump control unit.

Central heating

The heat pump can supply up to 3 heating circuits – 1 heating circuit without and 2 heating circuits with mixer. The mixer extension kit (accessories) is required to control the mixer for the second heating circuit with mixer.

Room cooling

Rooms can be cooled either via 1 heating/cooling circuit or 1 separate cooling circuit. Hydraulic components need to be provided on site for this purpose.

Heat pump control unit

The entire system is monitored and controlled by the integral Vitotronic 200 heat pump control unit, type WO1C.

Type BWS 351.B (heat pump stage 2)

Heat pump stage 2 is used to extend the output of type BW 301.B (heat pump stage 1).

Note

Heat pump stage 2 must be installed to the left of heat pump stage 1.

Design

Heat pump stage 2 has a separate refrigerant circuit with refrigerant circuit controller, but no separate heat pump control unit. Stage 2 is switched via the heat pump control unit of stage 1.

Product information (cont.)

Hydraulics

On the primary side of a 2-stage version, either use a separate primary pump for each stage, or use a shared primary pump. Irrespective of this, the flow and return temperature sensors are installed in the primary circuit on the shared flow and return.

Depending on the hydraulic connection, heat pump stage 2 can be used both for central heating and for DHW heating. A separate secondary pump and circulation pump for cylinder heating (both accessories) are therefore required for the heat pump stage 2.

System examples

Available system examples: See www.viessmann-schemes.com.

Spare parts lists

Information about spare parts can be found on the Viessmann spare parts app.



Requirements regarding on-site connections

1-stage: Type BW 351.B

Installation

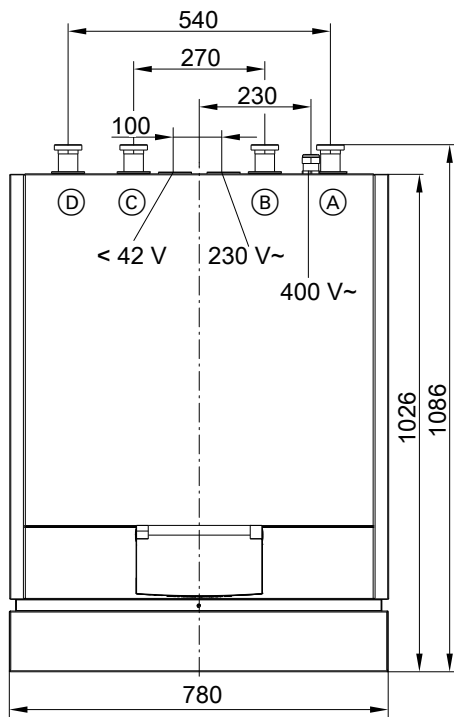
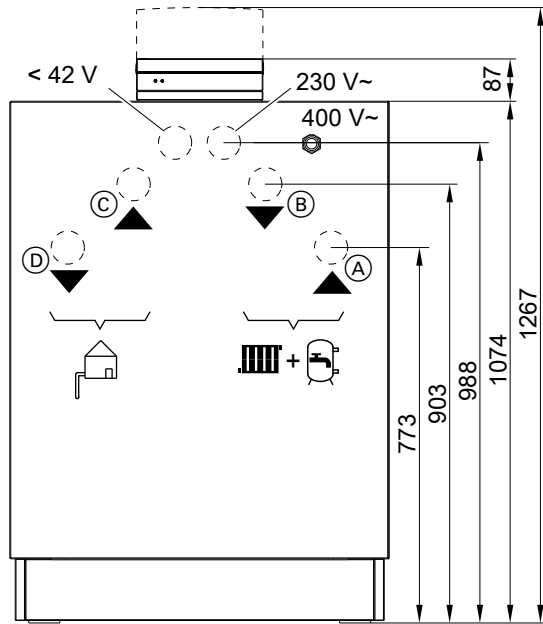

Fig. 1

- (A) Secondary circuit return
- (B) Secondary circuit flow
- (C) Primary circuit flow (heat pump brine inlet)
- (D) Primary circuit return (heat pump brine outlet)

Requirements regarding on-site connections (cont.)

2-stage: Type BW 351.B + BWS 351.B

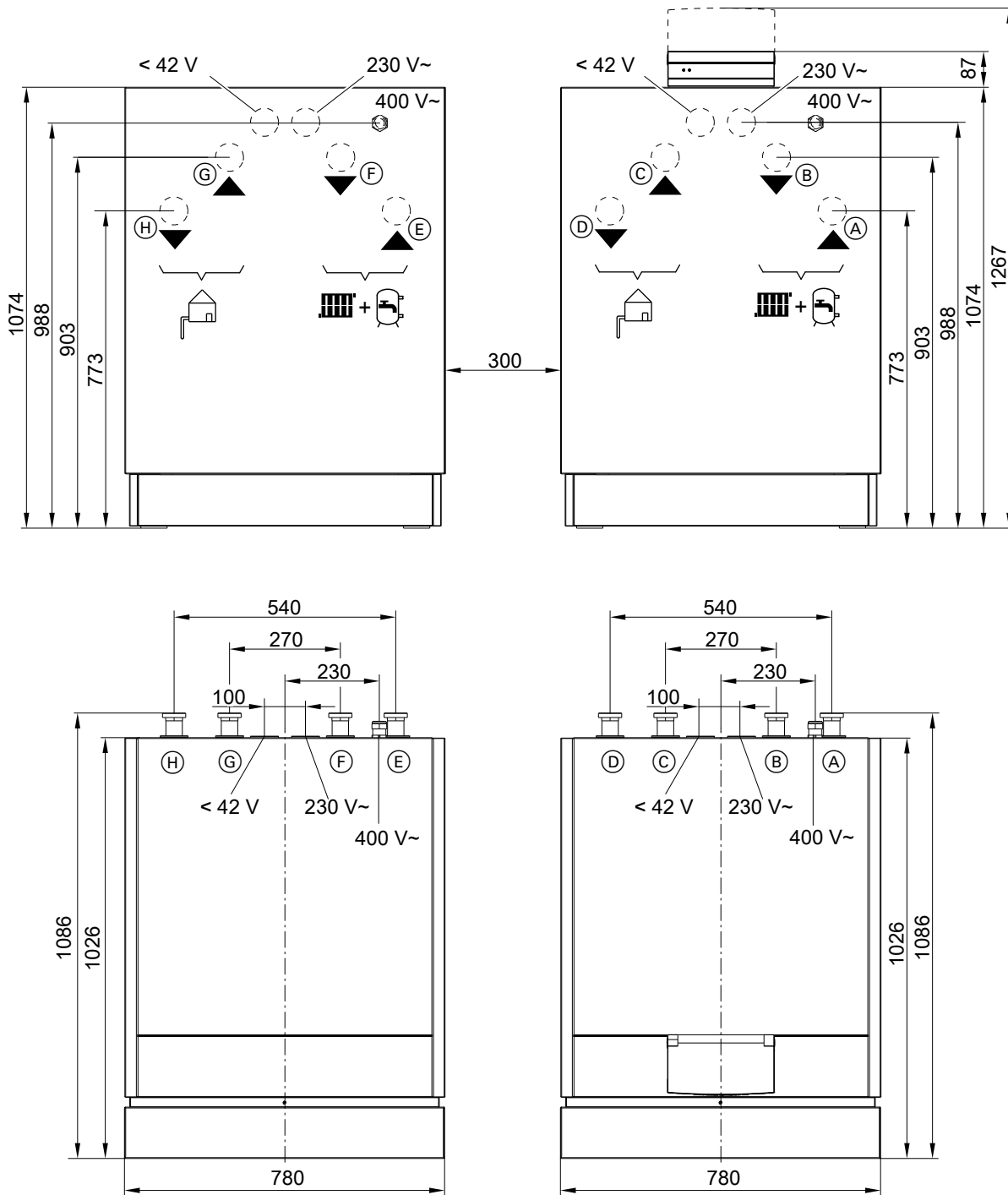

Fig. 2 Type BWS on the left; type BW on the right

- (A)/(E) Secondary circuit return
- (B)/(F) Secondary circuit flow
- (C)/(G) Primary circuit flow (heat pump brine inlet)
- (D)/(H) Primary circuit return (heat pump brine outlet)

Siting and transport requirements

Transport

For handling purposes, the heat pump module can be removed: See page 70.

Preparing for installation

Siting and transport requirements (cont.)

- ! Please note**
Impacts, compression and tensile loads can cause damage to the outside panels of the appliance.
Never put weight on the top, front or side panels of the appliance.

- ! Please note**
Tilting the compressor at a steep angle inside the heat pump can result in appliance damage.
Max. tilting angle: 45° for a very short time

Installation room requirements

- ! Please note**
Unfavourable ambient conditions can lead to malfunctions and appliance damage.

The installation room must be dry and free from the risk of frost:

- Ensure ambient temperatures between 0 and 35 °C.
- Max. 70 % relative humidity (corresponds to an absolute humidity of approx. 25 g water vapour/kg dry air)

- ! Danger**
Dust, gases and vapours can be damaging to health and trigger explosions.
Avoid dust, gases and vapours in the installation room.

- ! Please note**
Overloading the floor can result in damage to the building structure.
Observe the permissible floor load. Take the total weight of the appliance into account.

Total weight

Type	Weight in kg	
BW	351.B20	270
	351.B27	285
	351.B33	310
	351.B42	315

Type	Weight in kg	
BWS	351.B20	265
	351.B27	280
	351.B33	305
	351.B42	310

To prevent the transmission of structure-borne noise, never site the appliance above ceilings with wooden joists, e.g. in the attic.

Minimum room volume (to EN 378)

Type	Refrigerant charge in kg	Minimum room volume in m ³
▪ BW	351.B20	5.3
▪ BWS	351.B27	7.0
	351.B33	8.6
	351.B42	8.7

Minimum clearances for 1-stage (type BW 351.B)

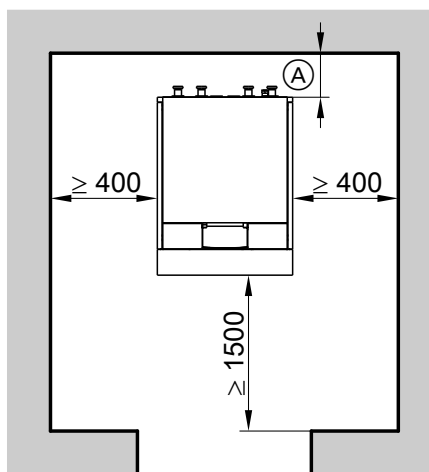

Fig. 3

- Ⓐ Clearance subject to on-site installation and site conditions

Note

- Observe clearances for installation and maintenance.
- Additional strain relief clamps are required for the power cables if the clearance behind the heat pump is more than 80 mm.

Siting and transport requirements (cont.)

Minimum clearances for 2-stage (type BW 351.B + BWS 351.B)

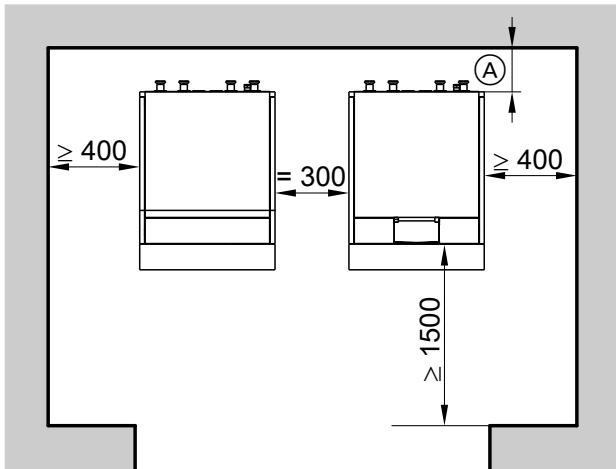

Fig. 4

Ⓐ Clearance subject to on-site installation and site conditions

Note

- Observe clearances for installation and maintenance.
- Additional strain relief clamps are required for the power cables if the clearance behind the heat pump is more than 80 mm.

Installation sequence

Positioning the heat pump

Position the heat pump according to the details on page 11.

Levelling the heat pump

Note

If the adjustable feet are used to compensate for an uneven floor (max. 10 mm), the pressure load on the feet must be distributed evenly.

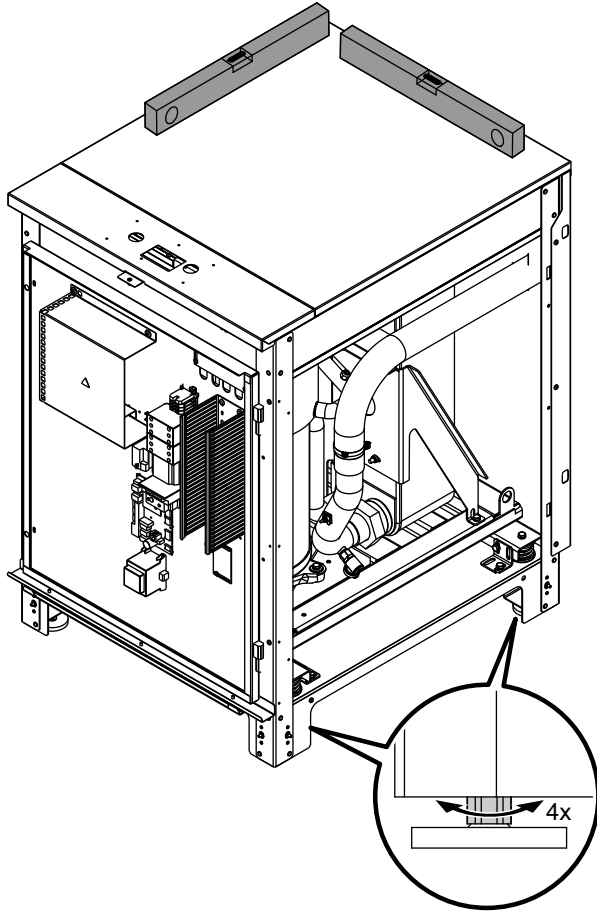

Fig. 5

Positioning the heat pump (cont.)**Removing the transport brackets****Please note**

Operating the appliance without first removing the transport brackets will cause vibrations and excessive noise.

Undo the transport brackets and secure them to the base support.

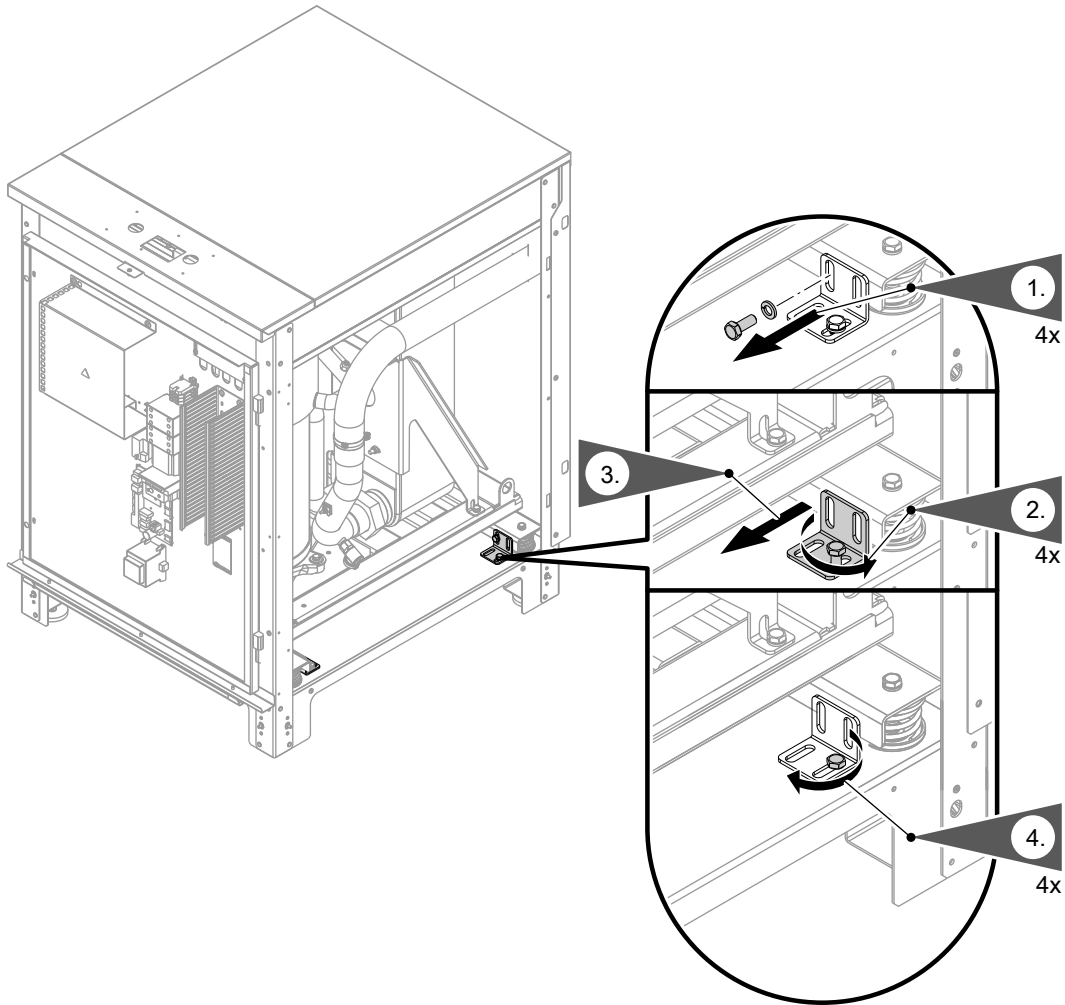

Fig. 6

Removing the top panel

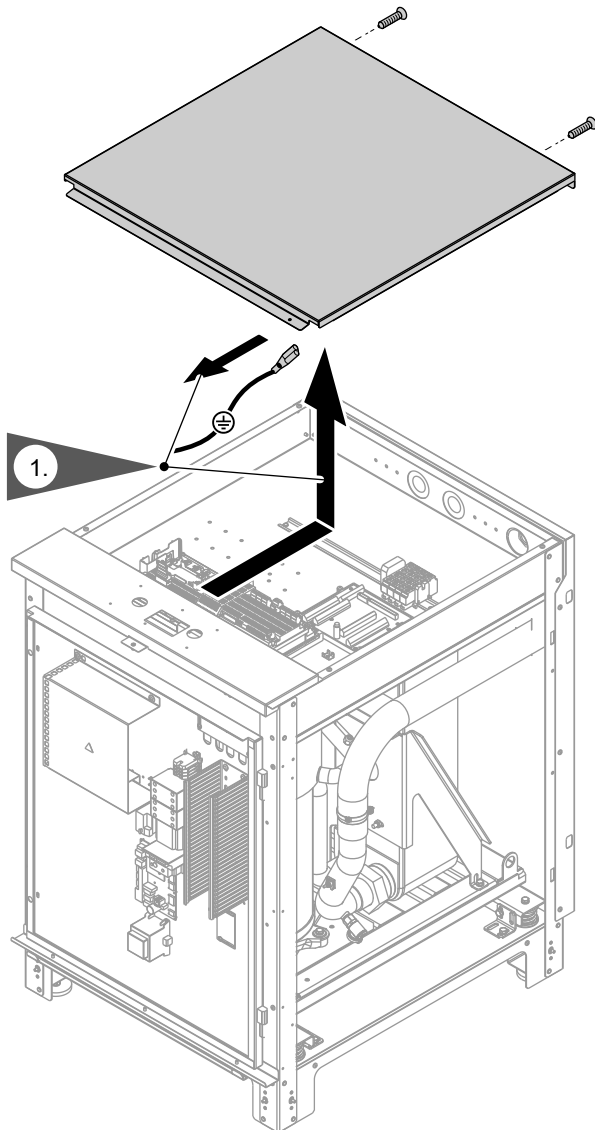

Fig. 7

Making the hydraulic connections

- For arrangement of hydraulic connections: See page 10.
- Make the hydraulic connections between the two heat pumps above the heat pumps (on site).
- All required components (with a suitably designed plate heat exchanger) for the cooling circuit must be provided on site.
- An instantaneous heating water heater (on site) can **only** be installed outside the heat pump. The system flow temperature sensor must be installed in the flow direction downstream of the instantaneous heating water heater.

Making the hydraulic connections (cont.)

Connecting the primary circuit

- !** **Please note**
The heat transfer medium can cause corrosion damage to on-site lines and components. The components and lines used must be resistant to the heat transfer medium. Never use zinc-plated/galvanised pipes.

1. Equip the primary circuit with an expansion vessel and safety valve (to DIN 4757).

Note

- The expansion vessel must be approved to DIN 4807. The diaphragms of the expansion vessel and safety valve must be suitable for the heat transfer medium.
- The blow-down and drain pipes should terminate in a container. This container must be able to hold the maximum possible expansion volume of the heat transfer medium.

2. Ensure adequate thermal and anti-vibration insulation where pipes penetrate walls.
3. Connect primary pipes to heat pump.

- !** **Please note**
Mechanically loaded hydraulic connections lead to leaks, vibration and appliance damage. Connect on-site lines so that they are free of load and torque stress.

- !** **Please note**
Leaking hydraulic connections lead to appliance damage. Ensure the diaphragm grommets at the hose outlets are seated correctly. Seal hose outlets with sealing tape if necessary.

4. Insulate pipes inside the building to prevent heat and vapour diffusion.
5. Charge the primary circuit with Viessmann heat transfer medium and vent.

Note

Ensure frost protection down to $-19\text{ }^{\circ}\text{C}$. Viessmann heat transfer medium is a ready-mixed ethylene glycol-based medium. It contains inhibitors for corrosion protection. The heat transfer medium can be used at temperatures down to $-19\text{ }^{\circ}\text{C}$.

Note

For diaphragm grommets, see page 48.

Connecting the secondary circuit

1. Equip the secondary circuit on site with an expansion vessel and safety assembly (in accordance with DIN 4757). Fit the safety assembly to the on-site line in the heating water return.

Installation sequence

Making the hydraulic connections (cont.)

2. Connect secondary lines to the heat pump ($\varnothing \geq 54$ mm).



Please note

Mechanically loaded hydraulic connections lead to leaks, vibrations and appliance damage.
Connect on-site lines so that they are free of load and torque stress.



Please note

Leaking hydraulic connections lead to appliance damage.

- Check the internal and on-site hydraulic connections for leaks.
- In the event of leaks, drain off liquid via the drain valve. Check the seating of seal rings. **Always** replace displaced seal rings.
- Ensure the diaphragm grommets at the hose outlets are seated correctly. Seal hose outlets with sealing tape if necessary. Position of diaphragm grommets for hoses: See page 48.

3. Fill and vent secondary circuit.
Observe additional information regarding filling and venting: See page 51.

4. Thermally insulate lines inside the building.

Note

- Ensure the minimum flow rate, e.g. by means of an overflow valve: See "Specification" on page 84 onwards.
- In underfloor heating circuits, install a temperature limiter on site to restrict the maximum temperature of the underfloor heating system.

Electrical connection

Preparing the electrical connections

Cables

- For cable lengths and cable cross-sections, see the following tables.
- For accessories:
Cables with the required number of cores for external connections.
Prepare an on-site distribution box.



Danger

Damaged wiring insulation wiring can lead to serious injury from electrical current and result in appliance damage.
Route cables so that they cannot touch very hot, vibrating or sharp-edged components.



Danger

Incorrect wiring can lead to serious injury from electrical current and result in appliance damage.

Take the following measures to prevent drifting of wires into the adjacent voltage area:

- Route LV leads < 42 V separately from cables > 42 V/230 V~/400 V~ and secure with cable ties.
- Only strip the minimum of insulation from cables as close as possible to the terminals and bundle tightly to the corresponding terminals.
- If 2 components are connected to the same terminal, press both cores together in a **single** wire ferrule.

Required cable lengths in the heat pump plus wall clearance

Type	BW 351.B	BWS 351.B
Heat pump control unit power supply 230 V~	1.0 m	—
Compressor power supply 400 V~	1.0 m	1.0 m
Additional connecting cables	1.5 m	—

Electrical connection (cont.)

Recommended power cables

Power supply		Cable	Max. cable length
Compressor 400 V~	Type BW/BWS 351.B20	5 x 2.5 mm ²	50 m
	Type BW/BWS 351.B27	5 x 4.0 mm ²	50 m
	Type BW/BWS 351.B33	5 x 4.0 mm ²	50 m
	Type BW/BWS 351.B42	5 x 6.0 mm ²	50 m
Heat pump control unit 230 V~	Without power-OFF	3 x 1.5 mm ²	40 m
	With power-OFF	5 x 1.5 mm ²	40 m

Installing the programming unit (type BW 351.B)

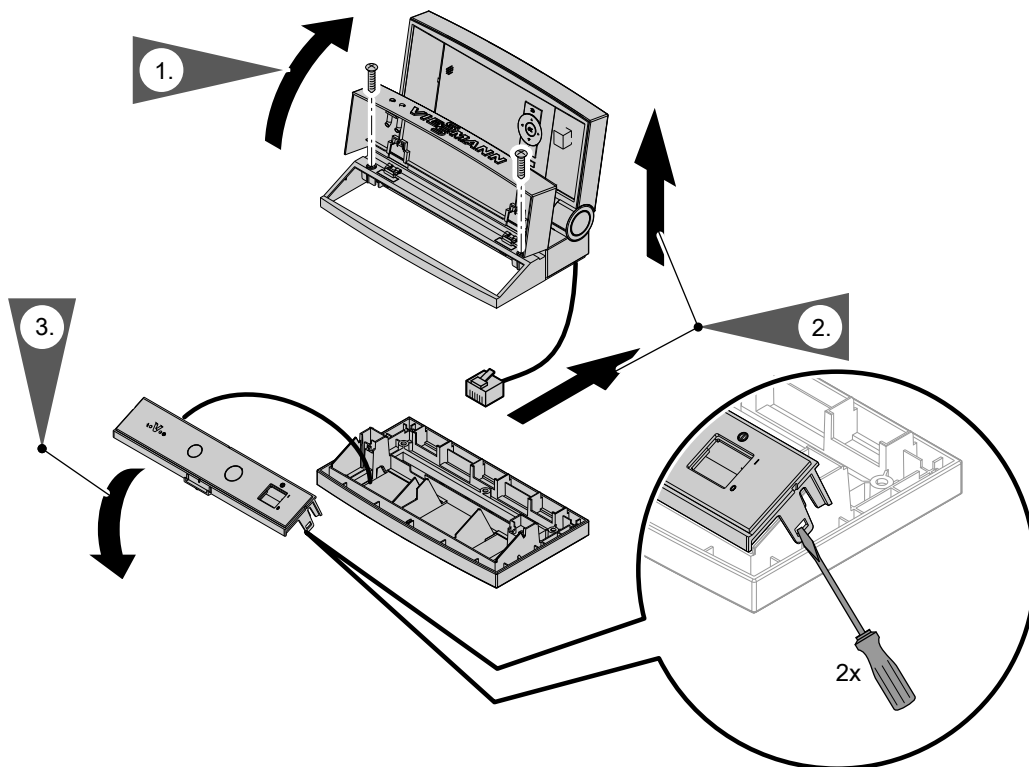

Fig. 8

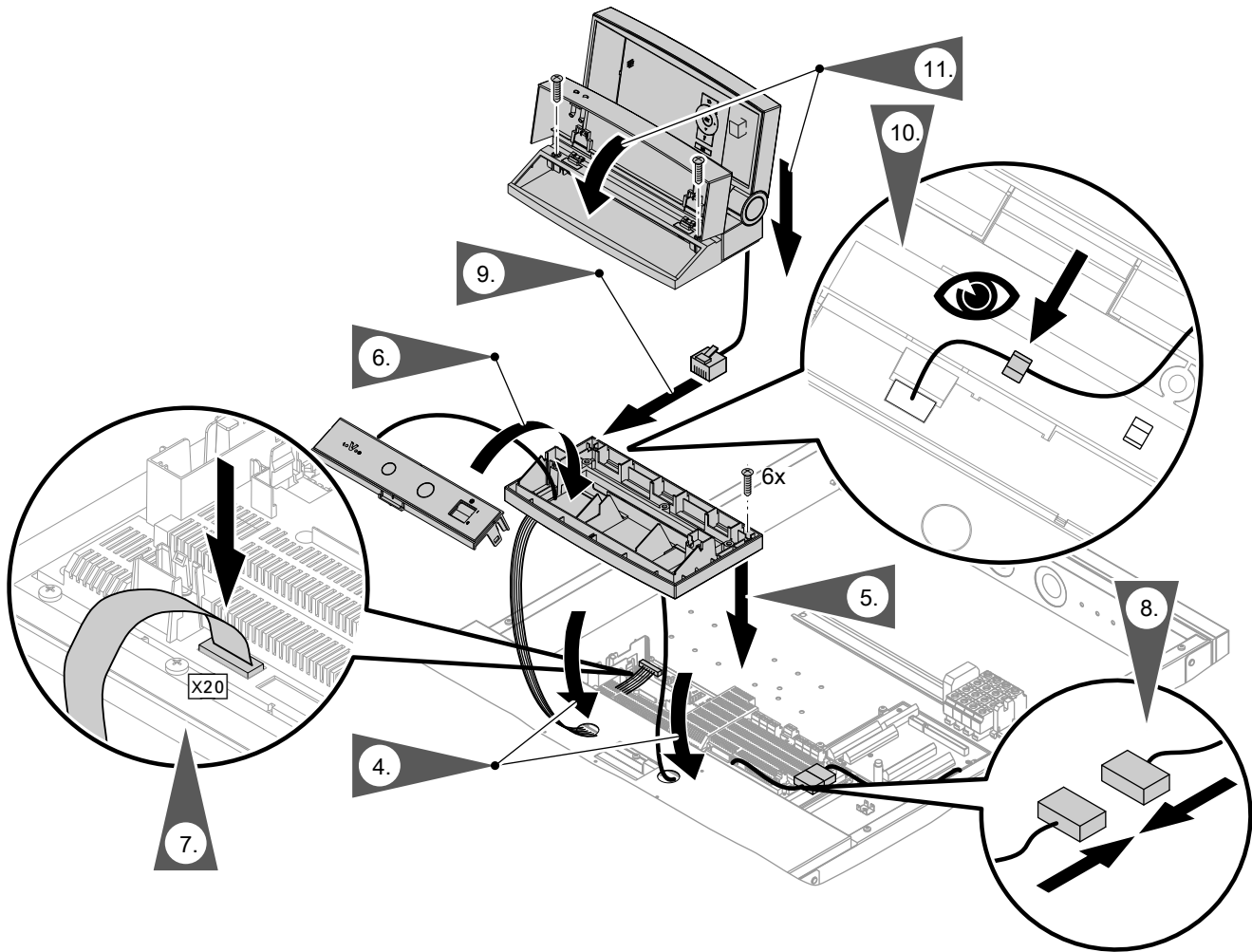

Fig. 9

Routing cables to the wiring chamber

When routing the on-site power cables, observe the location of the cable entries into the appliance through its back panel: See page 10.

Electrical connection (cont.)

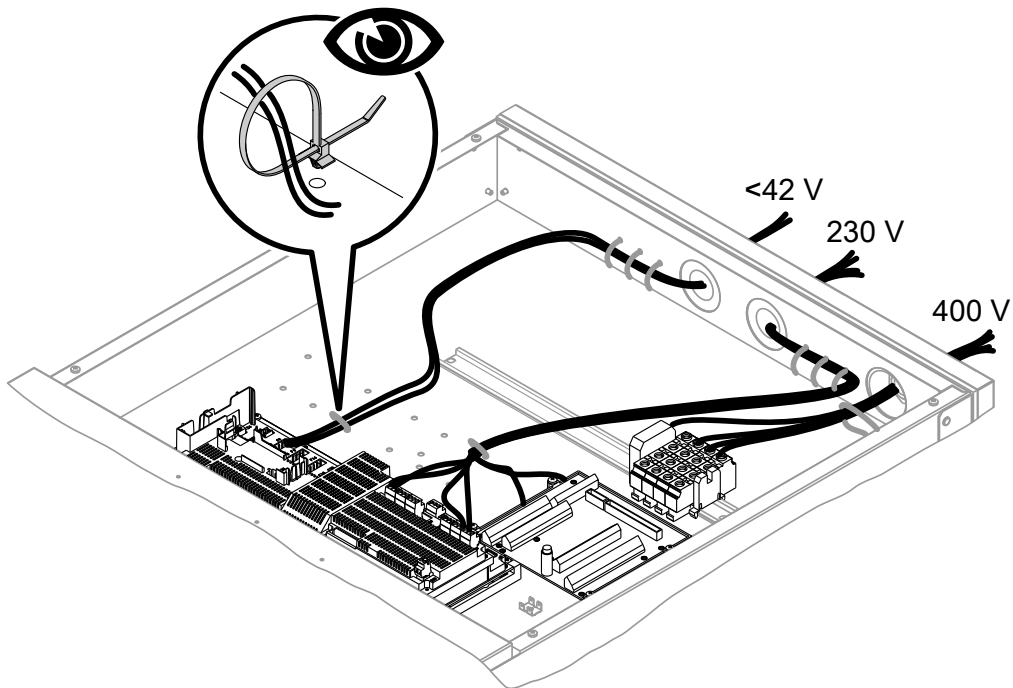

Fig. 10

1. Route LV leads through the "< 42 V" opening to the terminal area of the heat pump control unit. Provide strain relief using the cable ties supplied.
2. Route 230 V cables through the "230 V" opening to the terminal area of the heat pump control unit.
3. Route the compressor power cable through the "400 V" opening to the terminal area. For power supply, see from page 35.

Note

Route LV leads and 230 V cables as far apart as possible.

Electrical connection (cont.)

Making the electrical connection of heat pump stage 1 (type BW 351.B) and stage 2 (type BWS 351.B)

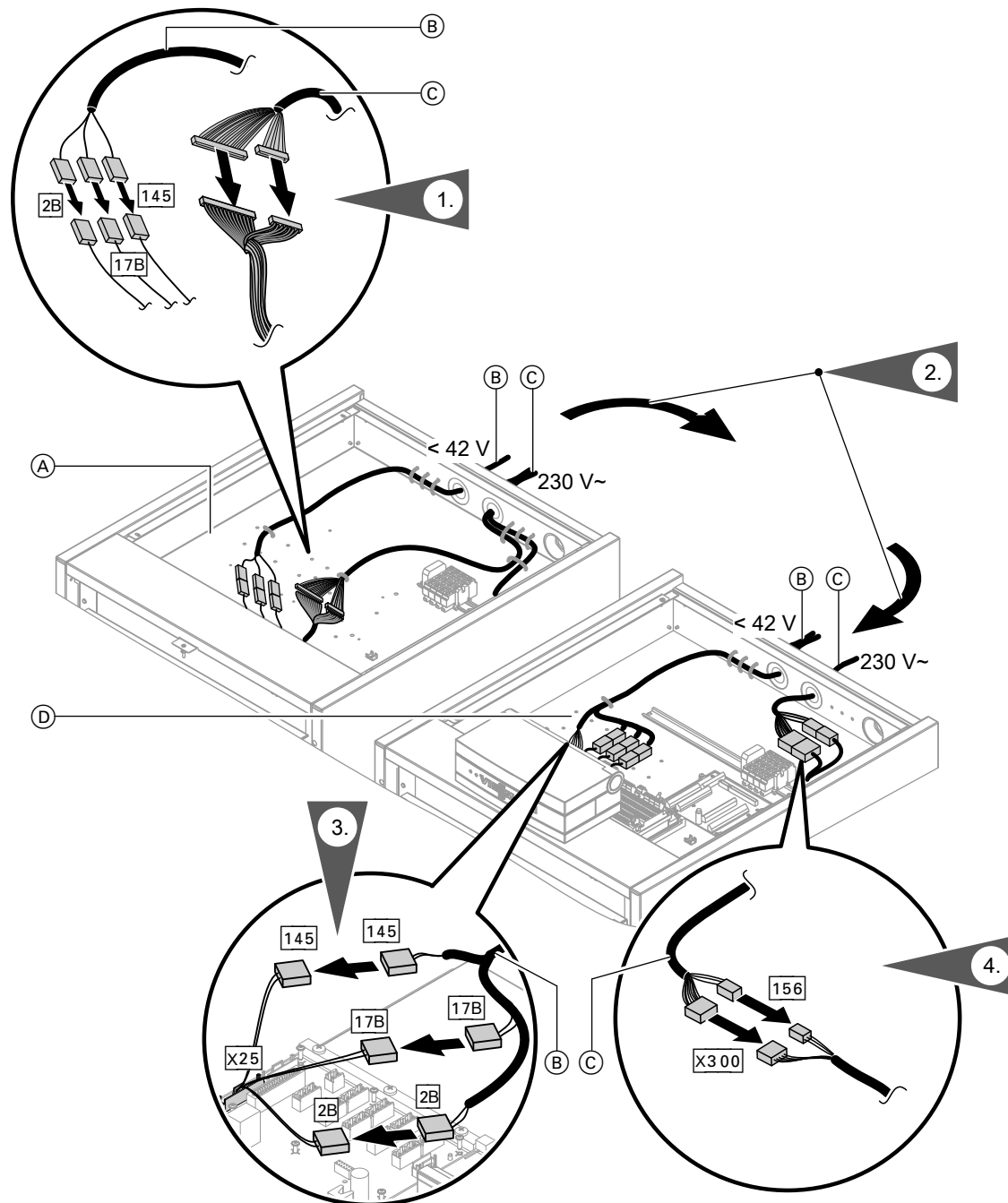

Fig. 11

- (A) Wiring chamber, heat pump stage 2 (type BWS)
- (B) LV <math>< 42\text{ V}</math> connecting leads:
 - With plugs 2B, 17B and 145 in the wiring chamber of heat pump stage 1 (type BW)
 - With plugs 2B, 17B and 145 in the wiring chamber of heat pump stage 2 (type BWS)
- (C) 230 V~ connecting cables:
 - With plugs without ID in the wiring chamber of heat pump stage 2 (type BWS)
 - With plugs X300 and 156 in the wiring chamber of heat pump stage 1 (type BW)
- (D) Wiring chamber, heat pump stage 1 (type BW)

Electrical connection (cont.)

Overview of electrical connections in the heat pump control unit (type BW 351.B)

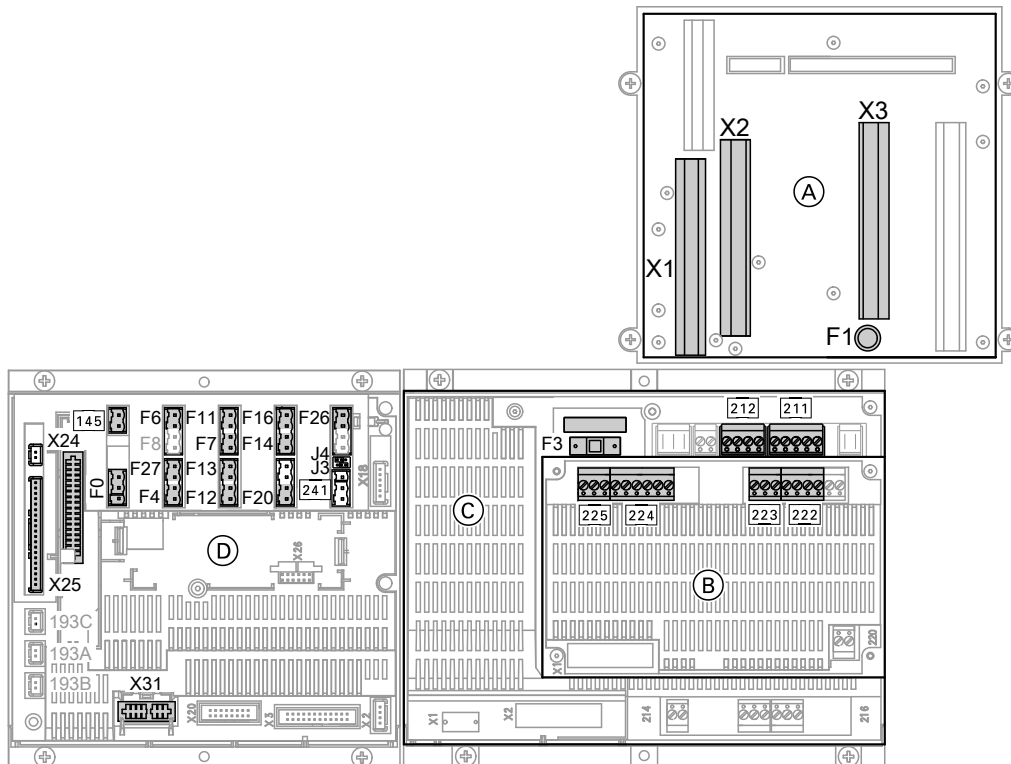

Fig. 12

- (A) Cross connect PCB: See page 31.
 F1 Fuse 6.3 A (slow)
- (B) Expansion PCB on main PCB: See page 27.
- (C) Main PCB: See page 23.
 F3 Fuse 6.3 A (slow)
- (D) Controller and sensor PCB: See page 33.

Main PCB (function components 230 V~)



Information regarding the connection values

- The specified output is the recommended connected load.
- The total output of all components connected directly to the heat pump control unit (e.g. pumps, valves, message facilities, contactors) must not exceed 1000 W.
 If the total output is < 1000 W, the individual rating of a component (e.g. pump, valve, message facility, contactor) can be greater than specified. However, the breaking capacity of the corresponding relay must not be exceeded.
- The stated current indicates the max. switching current of the switching contact (observe the total current of 5 A).
- Controls for external heat source and central fault messages are unsuitable for safety LV.

Set the required parameters during commissioning:
 See page 51 onwards.

Electrical connection (cont.)

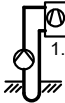
Plug 211

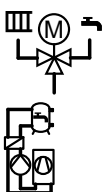

Terminals	Function	Explanation
211.1 	<ul style="list-style-type: none"> Primary pump (heat pump stage 1 or shared primary pump) Control of well pump 	<p>Connection values</p> <ul style="list-style-type: none"> Output: 200 W Voltage: 230 V~ Max. switching current: 4(2) A
211.2 	Secondary pump (heat pump stage 1)	<ul style="list-style-type: none"> In systems without a heating water buffer cylinder, no other heating circuit pump is required (see terminal 212.2). Connect a temperature limiter in series to restrict the maximum temperature for underfloor heating circuits (if installed). <p>Connection values</p> <ul style="list-style-type: none"> Output: 140 W Voltage: 230 V~ Max. switching current: 4(2) A
211.3 	Control of instantaneous heating water heater, stage 1	<p>Connection values</p> <ul style="list-style-type: none"> Output: 10 W Voltage: 230 V~ Max. switching current: 4(2) A
211.4 	<ul style="list-style-type: none"> 3-way diverter valve "central heating/DHW heating" Circulation pump for cylinder heating 	<p>Connection values</p> <ul style="list-style-type: none"> Output: 130 W Voltage: 230 V~ Max. switching current: 4(2) A
211.5 * NC	Control of the natural cooling function	<p>Circuit on site</p> <p>Connection values</p> <ul style="list-style-type: none"> Output: 10 W Voltage: 230 V~ Max. switching current: 4(2) A

Plug 212

Terminals	Function	Explanation
212.1 * AC	Control of the active cooling function	<p>Circuit on site</p> <p>Connection values</p> <ul style="list-style-type: none"> Output: 10 W Voltage: 230 V~ Max. switching current: 4(2) A
212.2 	Heating circuit pump for heating circuit without mixer A1/HC1	<ul style="list-style-type: none"> This pump is connected in addition to the secondary pump if a heating water buffer cylinder is installed. Connect a temperature limiter in series to restrict the maximum temperature for underfloor heating circuits (if installed). <p>Connection values</p> <ul style="list-style-type: none"> Output: 100 W Voltage: 230 V~ Max. switching current: 4(2) A

Electrical connection (cont.)

Plug 212

Terminals	Function	Explanation
212.3 	DHW circulation pump	Connection values <ul style="list-style-type: none"> ▪ Output: 50 W ▪ Voltage: 230 V~ ▪ Max. switching current: 4(2) A
212.4 	3-way diverter valve for heating water buffer cylinder bypass or heat pump in the case of dual alternative mode	Connection values <ul style="list-style-type: none"> ▪ Output: 130 W ▪ Voltage: 230 V~ ▪ Max. switching current: 4(2) A

Connecting a temperature limiter as a maximum temperature limiter for underfloor heating

Connecting a general temperature limiter (B)

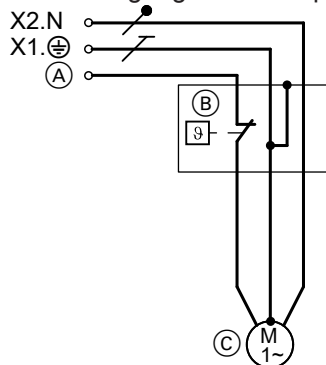

Fig. 13

Connecting the temperature limiter, part no. 7151728, 7151729 (B)

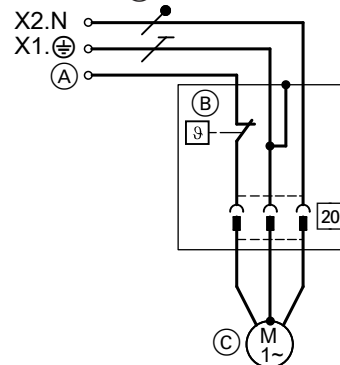

Fig. 14

	Connection (A) to control unit	Circulation pump (C)
Heating circuit without mixer A1/HC1		
▪ Without heating water buffer cylinder	211.2	Secondary pump
▪ With heating water buffer cylinder	212.2	Heating circuit pump A1/HC1
Heating circuit with mixer M2/HC2	225.1	Heating circuit pump M2/HC2

Connecting the temperature limiter, part no. 7151728, 7151729 (B) to the mixer extension kit

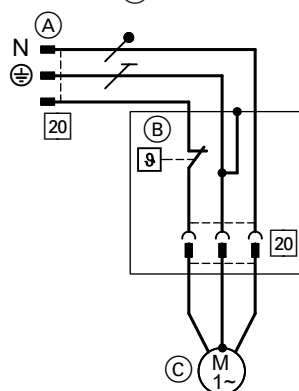





Fig. 15

- (A) Connect plug 20 to the extension kit.
- (B) Temperature limiter
- (C) Heating circuit pump M3/HC3

Electrical connection (cont.)





Plug 214

Terminals	Function	Explanation
214.1  M2	External hook-up, heating/cooling circuits: Central heating demand, heating circuit M2/HC2	230 V~ digital input: <ul style="list-style-type: none"> ▪ 230 V~: Central heating demand for heating circuit M2/HC2 active ▪ 0 V: No demand ▪ Breaking capacity 230 V, 0.15 A
214.2  M2	External hook-up, heating/cooling circuits: Central cooling demand, heating circuit M2/HC2	230 V~ digital input: <ul style="list-style-type: none"> ▪ 230 V~: Central cooling demand for heating circuit M2/HC2 active ▪ 0 V: No demand ▪ Breaking capacity 230 V, 0.15 A
214.3  M3	External hook-up, heating/cooling circuits: Central heating demand, heating circuit M3/HC3	230 V~ digital input: <ul style="list-style-type: none"> ▪ 230 V~: Central heating demand for heating circuit M3/HC3 active ▪ 0 V: No demand ▪ Breaking capacity 230 V, 0.15 A
214.4  M3	External hook-up, heating/cooling circuits: Central cooling demand, heating circuit M3/HC3	230 V~ digital input: <ul style="list-style-type: none"> ▪ 230 V~: Central cooling demand for heating circuit M3/HC3 active ▪ 0 V: No demand ▪ Breaking capacity 230 V, 0.15 A

Note

If heat pump stage 2 is connected, the external hook-up for heating/cooling circuits is not possible.

Plug 216

Terminals	Function	Explanation
216.1  A1 	External hook-up, heating/cooling circuits: Central heating demand, heating circuit A1/HC1 Or Smart Grid: Floating contact 1	230 V~ digital input: <ul style="list-style-type: none"> ▪ 230 V~: Central heating demand for heating circuit A1/HC1 active ▪ 0 V: No demand ▪ Breaking capacity 230 V, 2 mA 230 V~ digital input: <ul style="list-style-type: none"> ▪ 230 V~: Contact active ▪ 0 V: Contact not active ▪ Breaking capacity 230 V, 2 mA
216.2  A1	External hook-up, heating/cooling circuits: Room cooling demand, heating circuit A1/HC1	230 V~ digital input: <ul style="list-style-type: none"> ▪ 230 V~: Room cooling demand for heating circuit A1/HC1 active ▪ 0 V: No demand ▪ Breaking capacity 230 V, 0.15 A
216.4 	Smart Grid: Floating contact 2	230 V~ digital input: <ul style="list-style-type: none"> ▪ 230 V~: Contact active ▪ 0 V: Contact not active ▪ Breaking capacity 230 V, 2 mA

Note

If heat pump stage 2 is connected, the external hook-up for heating/cooling circuits is not possible.

Electrical connection (cont.)





Expansion PCB on main PCB (230 V~ components)

Information regarding the connection values

- The specified output is the recommended connected load.
- The total output of all components connected directly to the heat pump control unit (e.g. pumps, valves, message facilities, contactors) must not exceed 1000 W.
If the total output is < 1000 W, the individual rating of a component (e.g. pump, valve, message facility, contactor) can be greater than specified. However, the breaking capacity of the corresponding relay must not be exceeded.
- The stated current indicates the max. switching current of the switching contact (observe the total current of 5 A).
- Controls for external heat source and central fault messages are unsuitable for safety LV.

Set the required parameters during commissioning:
See page 51 onwards.

Plug 222

Terminals	Function	Explanation
222.1  	Control of mixer motor for external heat generator Mixer CLOSE signal	Connection values <ul style="list-style-type: none"> ▪ Output: 10 W ▪ Voltage: 230 V~ ▪ Max. switching current: 0.2(0.1) A
222.2  	Control of mixer motor for external heat generator Mixer OPEN signal	Connection values <ul style="list-style-type: none"> ▪ Output: 10 W ▪ Voltage: 230 V~ ▪ Max. switching current: 0.2(0.1) A
222.3 222.4 	Control of external heat generators and 1 high limit safety cut-out each (on site, max. 70 °C), to switch off or switch between the following components: Central heating: <ul style="list-style-type: none"> ▪ Secondary pump, heat pump ▪ Secondary pump, heat pump stage 2 (if installed) ▪ External heat generator DHW reheating: <ul style="list-style-type: none"> ▪ Circulation pump for cylinder heating or ▪ 3-way diverter valve "central heating/DHW heating" 	Floating contact Connection values (contact breaking capacity) <ul style="list-style-type: none"> ▪ Voltage: 230 V~ (not suitable for safety LV) ▪ Max. switching current: 4(2) A Connections for high limit safety cut-outs for central heating: <ul style="list-style-type: none"> ▪ In series to the secondary pump (terminal 211.2 on the main PCB) ▪ In series to the secondary pump, heat pump stage 2 (terminal 224.3) ▪ In series for controlling the external heat generator (terminal 222.3) Connections for high limit safety cut-outs for DHW reheating: <ul style="list-style-type: none"> ▪ In series with the circulation pump for cylinder heating or 3-way diverter valve "central heating/DHW heating" (terminal 211.4 on main PCB)

Installation sequence

Electrical connection (cont.)

High limit safety cut-out for heat pump in conjunction with external heat generator

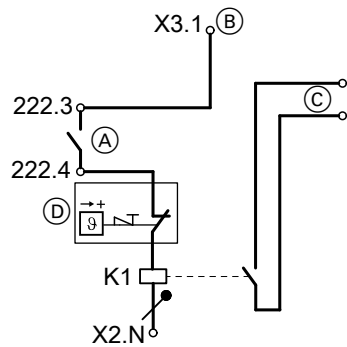

Fig. 16

- (A) Terminals on extension PCB
 - (B) Connect jumper across X3.1 and 222.3.
 - (C) Connection on external heat generator to terminals for "External demand"
 - (D) High limit safety cut-out to protect the heat pump (max. 70 °C)
- K1 Relay
- Sizing according to the external heat generator
 - Observe safety instructions.

Plug 223

Terminals	Function	Explanation
223.1 223.2	Central fault message	Floating contact: <ul style="list-style-type: none"> ▪ Closed: Fault ▪ Open: No fault ▪ Not suitable for safety LV
		Connection values (contact rating): <ul style="list-style-type: none"> ▪ Voltage: 230 V~ ▪ Max. switching current: 4(2) A

Central fault message

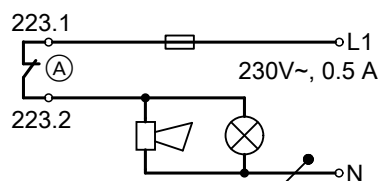
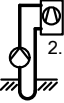



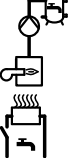

Fig. 17

- (A) Terminals on extension PCB

Electrical connection (cont.)

Plug 224

Terminals	Function	Explanation
224.2 	Primary pump for heat pump stage 2	Connection values <ul style="list-style-type: none"> ▪ Output: 200 W ▪ Voltage: 230 V~ ▪ Max. switching current: 4(2) A
224.3 	Secondary pump for heat pump stage 2	Connection values <ul style="list-style-type: none"> ▪ Output: 130 W ▪ Voltage: 230 V~ ▪ Max. switching current: 4(2) A
224.4 	Switching an instantaneous heating water heater, stage 2	Connection values <ul style="list-style-type: none"> ▪ Output: 10 W ▪ Voltage: 230 V~ ▪ Max. switching current: 4(2) A
224.5 	Circulation pump for cylinder heating for heat pump stage 2	Connection values <ul style="list-style-type: none"> ▪ Output: 130 W ▪ Voltage: 230 V~ ▪ Max. switching current: 4(2) A
224.6 	Cylinder loading pump (DHW side) 2-way shut-off valve	Connect cylinder loading pump and 2-way shut-off valve in parallel. Connection values <ul style="list-style-type: none"> ▪ Output: 130 W ▪ Voltage: 230 V~ ▪ Max. switching current: 4(2) A
224.7 	Circulation pump for DHW reheating or Control of immersion heater (in DHW cylinder)	Connection values <ul style="list-style-type: none"> ▪ Output: 100 W ▪ Voltage: 230 V~ ▪ Max. switching current: 4(2) A

Electrical connection (cont.)

Control and power circuit of the instantaneous heating water heater

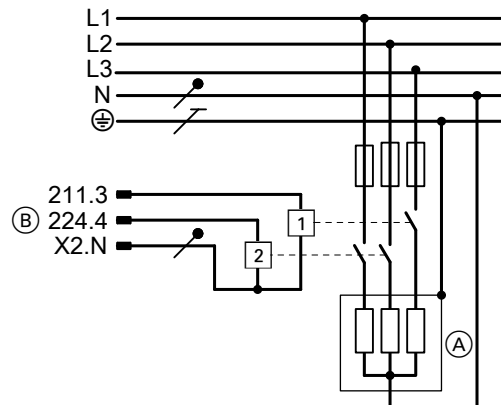

Fig. 18

- Ⓐ Instantaneous heating water heater
- Ⓑ Connection to the main PCB and expansion PCB
211.3 stage 1
224.4 stage 2

Immersion heater EHE 400 V~

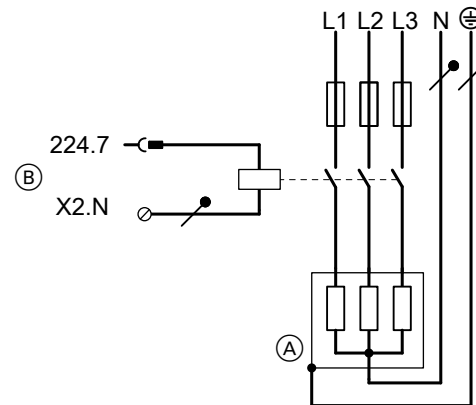

Fig. 19

- Ⓐ Immersion heater EHE, power supply 3/N/PE
400 V/50 Hz
- Ⓑ Terminals of the heat pump control unit



Plug 225

Terminals	Function	Explanation
225.1 M2 III	Heating circuit pump of the heating circuit with mixer M2/HC2	Connect a temperature limiter to restrict the maximum temperature for underfloor heating circuits (if installed) in series. Connection values: ▪ Output: 100 W ▪ Voltage: 230 V~ ▪ Max. control current: 4(2) A
225.2 M2 X ▼ II	Mixer motor control, heating circuit M2/HC2 Signal mixer CLOSE ▼	Connection values: ▪ Output: 10 W ▪ Voltage: 230 V~ ▪ Max. control current: 0.2(0.1) A
225.3 M2 X ▲ II	Mixer motor control, heating circuit M2/HC2 Signal mixer OPEN ▲	Connection values: ▪ Output: 10 W ▪ Voltage: 230 V~ ▪ Max. control current: 0.2(0.1) A



Electrical connection (cont.)

Cross connect PCB (message and safety connections)

Set the required parameters during commissioning:
See page 51 onwards.



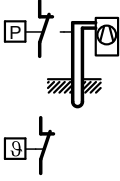





Terminals	Function	Explanation
F1	Fuse 6.3 A (slow)	Note Observe the total load 1000 W of all connected components.
X1	Earth conductor X1.⊕	Terminals for earth conductor of all associated system components
X2	Neutral conductor X2.N	Terminals for neutral conductor of all associated system components
X3	<ul style="list-style-type: none"> ▪ Power supply terminals of control unit "L1" and auxiliary components ▪ Switched phase L1: X3.1, X3.2, X3.3, X3.7, X3.11, X3.13 	Terminals for signal and safety connections Switched phase L1: <ul style="list-style-type: none"> ▪ Switched phase can be used for on-site system components. ▪ Observe the total load 1000 W of all connected components.
X3.1	Switched phase	
X3.2 X3.14 	"External blocking" signal: External blocking of compressor and pumps, mixer in control mode or CLOSE	Requires floating contact: <ul style="list-style-type: none"> ▪ Closed: Power-OFF enabled ▪ Open: No power-OFF ▪ Breaking capacity 230 V~, 2 mA Note <ul style="list-style-type: none"> ▪ The system may no longer be protected against frost. ▪ These and further external functions (e.g. provision of external set values) can alternatively be connected via the external EA1 extension. See "EA1 extension" installation instructions
X3.3 X3.4 	Flow switch	Requires floating contact: <ul style="list-style-type: none"> ▪ Closed: Heat pump in operation ▪ Open: Heat pump shut down ▪ Breaking capacity 230 V~, 0.15 A <ul style="list-style-type: none"> ▪ Jumper is used in some devices. ▪ No jumper should be installed if a flow switch is connected.
X3.6 X3.7 	Power-OFF	Requires floating contact: <ul style="list-style-type: none"> ▪ Closed: No blocking (safety chain continuous) ▪ Open: Blocking enabled ▪ Breaking capacity 230 V~, 0.15 A

Electrical connection (cont.)

Terminals	Function	Explanation
		<p>Note</p> <ul style="list-style-type: none"> No parameters need to be set No jumper should be installed if a power-OFF contact is connected. The compressor is "forced" off as soon as the contact opens. The power-OFF signal switches off the power supply to the relevant components, subject to the power supply utility. For the instantaneous heating water heater, the stages to be switched off can be selected ("Output for instant. heating water heater at power-OFF 790A"). The power supply for the heat pump control unit (3 x 1.5 mm²) and the cable for the power-OFF signal can be combined in a single 5-core cable. <p>In connection with Smart Grid: Do not connect the power-OFF signal. Do not remove jumper.</p>
<p>X3.8 X3.9</p> 	<p>Pressure switch, primary circuit and/or</p> <p>Frost stat or Jumper</p>	<p>Requires floating contact:</p> <ul style="list-style-type: none"> Closed: Safety chain has continuity Open: Safety chain interrupted; heat pump shut down Breaking capacity 230 V~, 0.15 A <ul style="list-style-type: none"> Connected in series if 2 safety components are installed Insert jumper if no safety components are installed.
<p>X3.10 X3.11</p> 	<p>Fault message, lag heat pump in a cascade or Jumper</p>	<p>Requires floating contact:</p> <ul style="list-style-type: none"> Closed: No fault Open: Fault Breaking capacity 230 V~, 0.15 A <p>No jumper should be installed if a message contact is connected.</p>
<p>X3.12 X3.13</p> 	<p>"External demand" signal: External starting of compressor and pumps, mixer in control mode or OPEN, changeover of the operating status of several system components</p>	<p>Requires floating contact:</p> <ul style="list-style-type: none"> Closed: Demand Open: No demand Breaking capacity 230 V~, 2 mA <p>Note These and further external functions (e.g. provision of external set values) can alternatively be connected via the external EA1 extension. See "EA1 extension" installation instructions</p>
<p>X3.17 X3.18</p>	<p>Fuse F1 6.3 A (slow)</p>	
<p>X3.18</p>	<p>Heat pump control unit power supply: Phase L1 X1.1 Earth conductor connection X2.1 Neutral conductor connection</p>	<p>Power supply 230 V~</p>

Electrical connection (cont.)**Controller and sensor PCB (sensors)**

Set the required parameters during commissioning:
See page 51 onwards.

Plug	Sensor	Type
F0.1/F0.2	Outside temperature sensor	NTC 10 kΩ
F0.2/F0.3	Radio clock receiver (on site)	DCF
F4	Buffer temperature sensor	NTC 10 kΩ
F6	Top cylinder temperature sensor	NTC 10 kΩ
F7	Bottom cylinder temperature sensor	NTC 10 kΩ
F11	Contact humidistat 24 V _~	—
F12	Flow temperature sensor, heating circuit with mixer M2/HC2	NTC 10 kΩ
F13	System flow temperature sensor with sensor well (downstream of the heating water buffer cylinder and external heat generator)	NTC 10 kΩ
F14	Flow temperature sensor, cooling circuit: Heating circuit without mixer A1/HC1 or separate cooling circuit SKK	NTC 10 kΩ
F16	Room temperature sensor, cooling circuit <ul style="list-style-type: none"> ▪ Required for separate cooling circuit SKK ▪ Recommended for heating/cooling circuit without mixer A1/HC1 	NTC 10 kΩ
F20	Boiler water temperature sensor, external heat generator	NTC 10 kΩ
F27	Flow temperature sensor, secondary circuit for heat pump stage 2	Pt500A (PTC)
		
 (X25.13/ X25.14)	Return temperature sensor, secondary circuit for heat pump stage 2 (if installed)	Pt500A (PTC)
	KM-BUS (wires interchangeable) Use the KM-BUS distributor (accessories) if several devices are connected. KM-BUS subscribers (examples): <ul style="list-style-type: none"> ▪ Mixer extension kit M3/HC3 ▪ Remote control: Set the heating circuit allocation on the remote control. ▪ EA1 extension, AM1 extension 	
	Modbus 2 (wires not interchangeable) Connection for energy meter of photovoltaic system	
J3	Jumper for terminator, Modbus 2 <ul style="list-style-type: none">  Terminator active (delivered condition)  Terminator not active 	
J4	Jumper for setting master/slave, Modbus 2 <ul style="list-style-type: none">  Heat pump control unit is slave  Heat pump control unit is master (delivered condition) 	
X18	Modbus 1 Viessmann appliances, e.g. ventilation unit Vitovent 300-F Note <i>If further Viessmann appliances are to be connected to Modbus 1, plug in the Modbus distributor (accessories): See "Modbus distributor" installation instructions.</i>	
X24	Connection, LON communication module (accessories): See installation instructions "LON communication module".	
X31	Coding card slot	

Electrical connection (cont.)

Plug	Sensor	Type
193 A	PWM signal, primary pump	
193 B	PWM signal, secondary pump	
193 C	PWM signal, circulation pump for cylinder heating	

Note

Flow temperature sensor for heating circuit with mixer M3/HC3: The flow temperature sensor for one heating circuit with mixer M3/HC3 is connected to the mixer extension kit (accessories).

Connecting the primary circuit flow/return temperature sensor, 2-stage heat pump

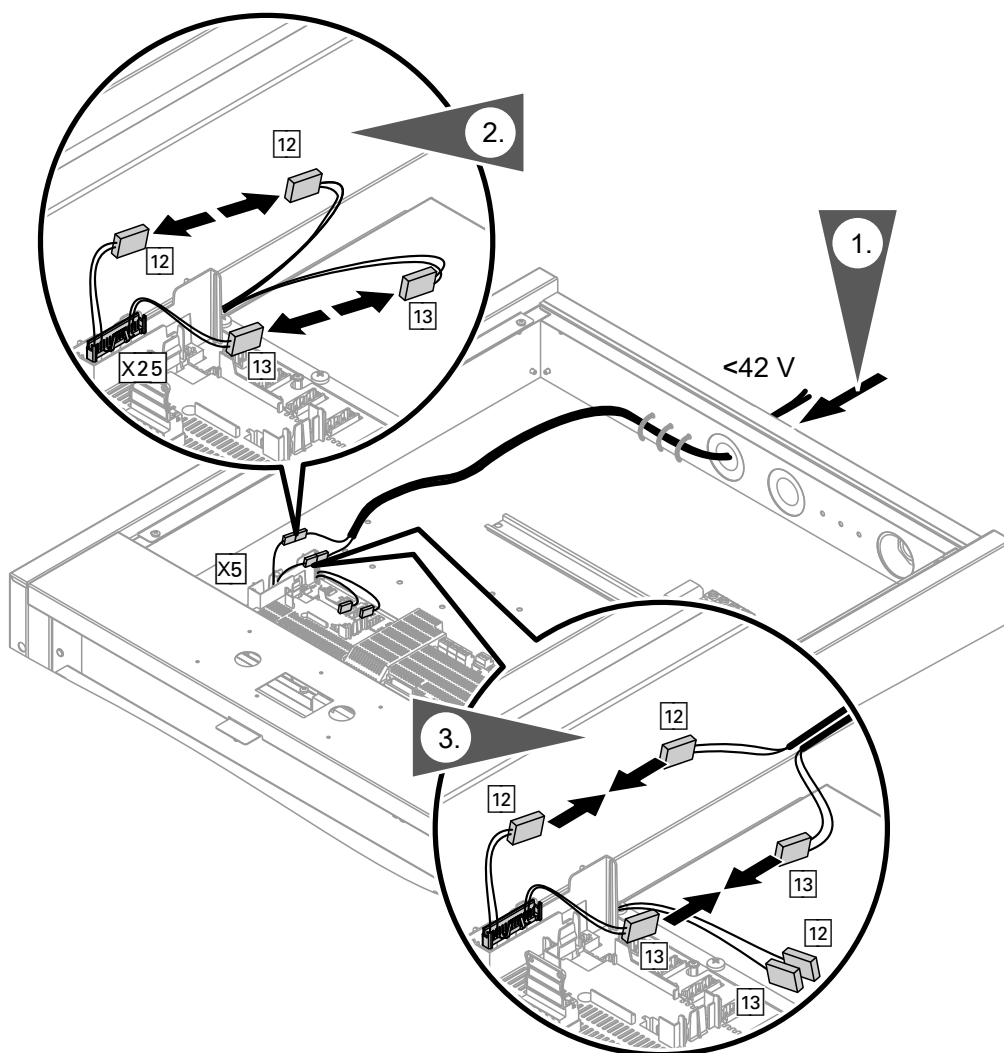

Fig. 20

- 12 Flow temperature sensor, primary circuit
- 13 Return temperature sensor, primary circuit

! Please note
 Unmarked sensor leads cannot be uniquely identified, e.g. during diagnosis.
 Mark sensor leads.

! Please note
 If sensor lead wires drift into the adjacent voltage area, this can cause appliance damage, e.g. when a wire comes loose.
 Secure sensor leads and stripped leads (with plug 12/13) to the other low voltage leads using the cable ties provided.

Electrical connection (cont.)

Swimming pool heating

Note

- Swimming pool heating is controlled via EA1 extension with KM-BUS.
- Make connections to EA1 extension **only** in accordance with Fig. 21.
- A filter circuit pump **cannot** be controlled via the heat pump control unit.

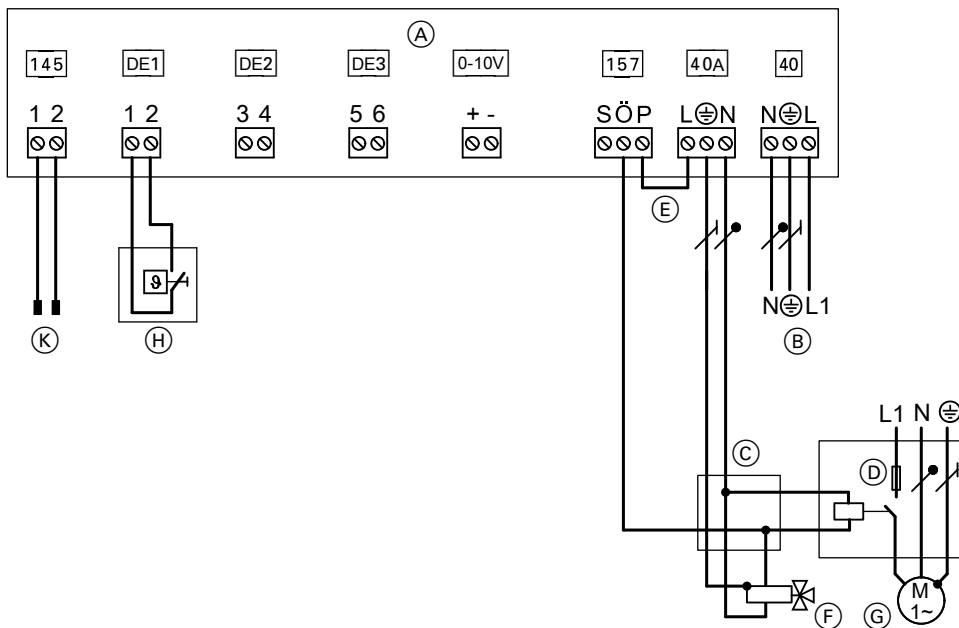



Fig. 21

- (A) EA1 extension
- (B) Power supply 1/N/PE 230 V/50 Hz
- (C) Junction box (on site)
- (D) Fuses and contactor for circulation pump for swimming pool heating (accessories)
- (E) Jumper
- (F) 3-way diverter valve for "Swimming pool" (zero volt: heating the heating water buffer cylinder)
- (G) Circulation pump for swimming pool heating (accessories)
- (H) Temperature controller for swimming pool temperature control (floating contact: 230 V~, 0.1 A, accessories)
- (K) KM-BUS connection to the controller and sensor PCB

Power supply

Isolators for non-earthed conductors

- Install an isolator in the power cable to provide omnipolar separation from the mains for all active conductors, corresponding to overvoltage category III (3 mm) for full isolation. This isolator must be fitted in the permanent electrical installation in line with installation requirements, e.g. mains isolator or upstream circuit breaker.
- We additionally recommend installing an AC/DC-sensitive RCD (RCD class B ) for DC (fault) currents that can occur with energy efficient equipment.
- Select and size residual current devices to DIN VDE 0100-530.



Danger

Incorrect electrical installations can lead to serious injury from electrical current and result in appliance damage.

Connect the power supply and implement all safety measures (e.g. RCD circuit) in accordance with the following regulations:

- IEC 60364-4-41
- VDE regulations
- TAR medium voltage VDE-AR-N-4110

Power supply (cont.)

⚠ Danger
The absence of system component earthing can lead to serious injury from electrical current and component damage in the event of an electrical fault.
The appliance and pipework must be connected to the equipotential bonding of the building.

⚠ Danger
Incorrect core assignment can lead to serious injury from electrical current and result in appliance damage.
Never interchange cores "L" and "N".

- Consult your power supply utility, which may offer different supply tariffs for the power circuits. Observe the technical connection conditions of the power supply utility.
 - If the compressor and/or instantaneous heating water heater (if installed) are operated at an economy tariff (power-OFF), provide an additional cable (e.g. 3 x 1.5 mm²) for the power-OFF signal from the distribution board (meter box) to the heat pump control unit.
- or**
- Combine the cables for the power-OFF signal and for the heat pump control unit power supply (3 x 1.5 mm²) in a 5-core cable.
- The power-OFF (for compressor and/or instantaneous heating water heater) is assigned via the type of connection and via parameter settings in the heat pump control unit.
In Germany, the power supply can be cut for a maximum of 3 x 2 hours per day (24 h).
 - The **heat pump control unit/PCB** must be supplied **without** power-OFF. Tariffs subject to possible shutdown must not be used here.

- When using power generated on site (use of power generated by the PV system to meet own requirements):
During the power-OFF period, it is **not** possible to operate the compressor with power generated on site.
- Protect the power cable for the heat pump control unit with an MCB/fuse of max. 16 A.
- For accessories and external components that will not be connected to the heat pump control unit, provide the power supply via the same MCB/fuse, or at least on the same phase, as the heat pump control unit.
Connection to the same MCB/fuse provides additional safety when the power is switched off. Observe the power consumption of the connected consumers.
- If the power supply to the appliance is connected with a flexible cable, ensure that the live conductors are pulled taut before the earth conductor in the event of strain relief failure. The length of the earth conductor wire will depend on the design.

Information regarding the compressor power supply

- **! Please note**
Incorrect phase sequence can cause damage to the appliance.
Make the compressor power supply **only** in the phase sequence specified (see terminals) with a **clockwise** rotating field.
- Characteristics of the compressor power MCBs: See "Specification".

Heat pump control unit power supply 230 V~

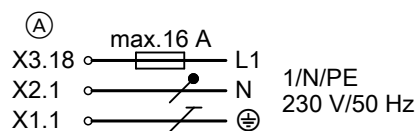

Ⓐ Mains terminals inside the heat pump control unit

Note

*This supply must **never** be blocked.*

- Max. fuse rating 16 A
- Standard tariff: No economy tariff with power-OFF possible for the heat pump control unit
- Recommended power cable:
3 x 1.5 mm²
- Recommended power cable with power-OFF for compressor/instantaneous heating water heater:
5 x 1.5 mm²

Power supply (cont.)

Compressor power supply 400 V~

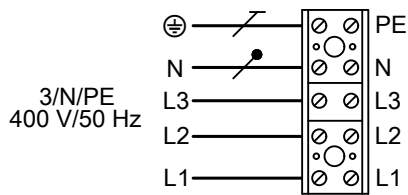

Fig. 23

- Economy tariff and power-OFF can be used
- No parameters need to be set when using economy tariff with power-OFF. The compressor is shut down during the power-OFF time.

Type	Recommended power cable			Fuse protection
	Cable	Max. cable length		
▪ BW	351.B20	5 x 2.5 mm ²	50 m	C25A, 3-pole
▪ BWS	351.B27	5 x 4.0 mm ²	50 m	C32A, 3-pole
	351.B33	5 x 4.0 mm ²	50 m	C32A, 3-pole
	351.B42	5 x 6.0 mm ²	50 m	C40A, 3-pole

Power supply with power-OFF: Without on-site load disconnect

The power-OFF signal is connected directly to the heat pump control unit. When power-OFF is enabled, the compressor is "forced" off; in the 2-stage version (type BW + BWS), **both** compressors are switched off. Parameter "**Output for instant. heating water heater at power-OFF 790A**" determines whether and at what stage an instantaneous heating water heater (if installed) remains operational during power-OFF.



"Vitotronic 200 heat pump control unit" service instructions

Note

Observe the technical connection conditions of the relevant power supply utility.

1-stage (type BW 351.B)

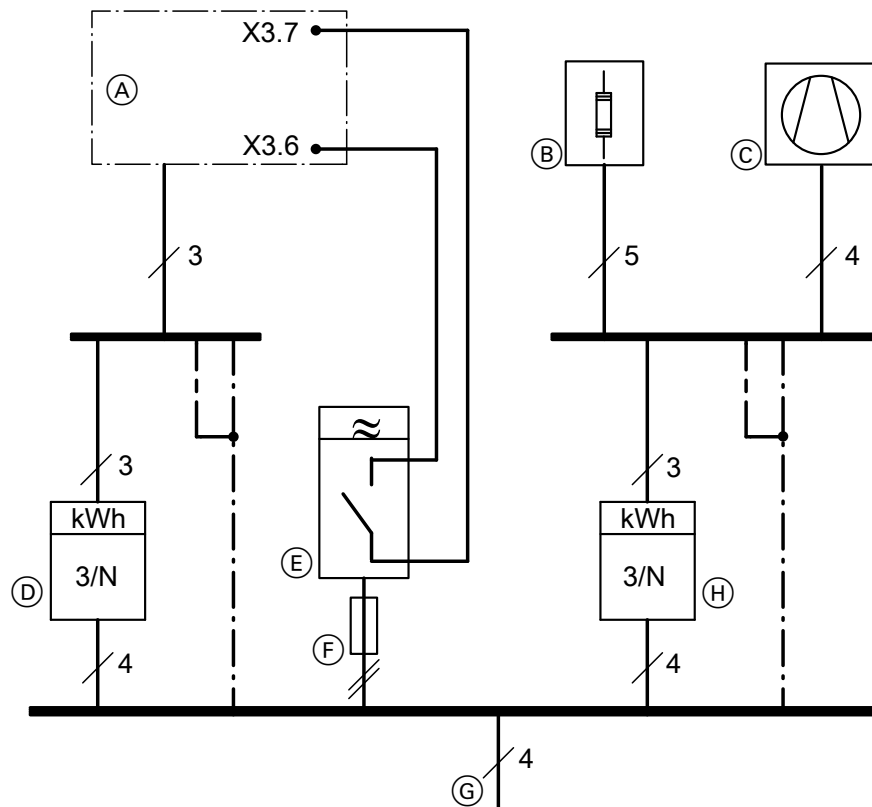

Fig. 24 Shown without fuses and RCDS

- | | |
|---|---|
| <ul style="list-style-type: none"> Ⓐ Heat pump control unit (connection on cross connect PCB) Ⓑ Instantaneous heating water heater (if installed) Ⓒ Compressor Ⓓ Premium tariff meter | <ul style="list-style-type: none"> Ⓔ Ripple control receiver (contact open: Power-OFF enabled) Ⓕ Backup fuse, ripple control receiver Ⓖ Feed: TNC system Ⓗ Economy tariff meter |
|---|---|

Power supply (cont.)

2-stage (type BW 351.B + BWS 351.B)

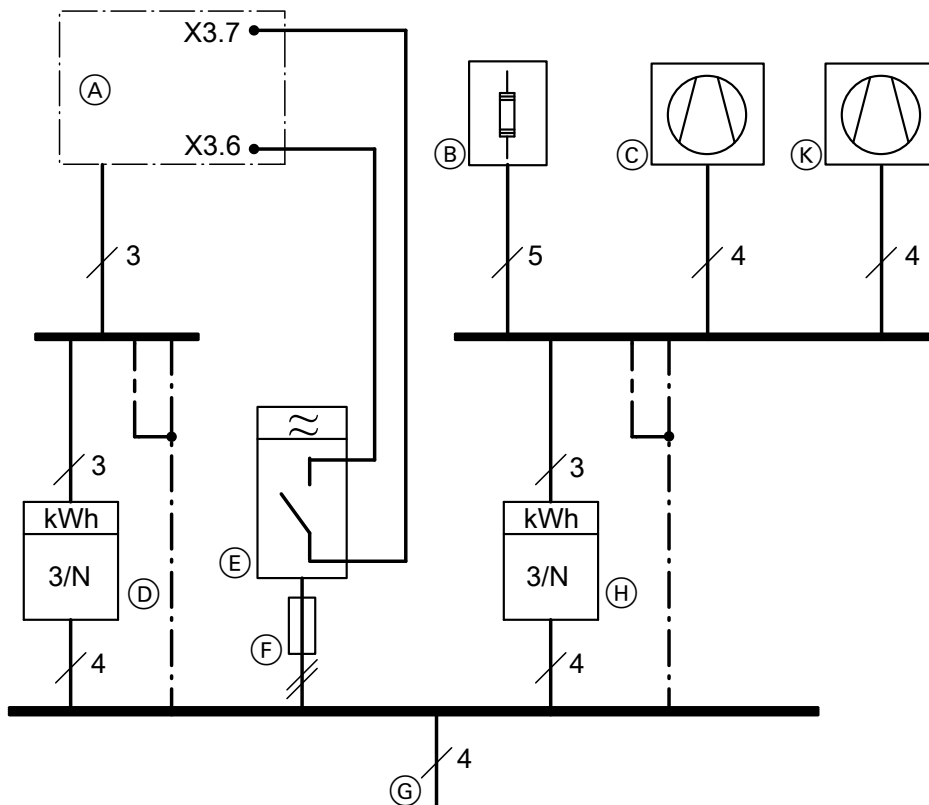

Fig. 25 Shown without fuses and RCDs

- (A) Heat pump control unit (connection on cross connect PCB)
- (B) Instantaneous heating water heater (if installed)
- (C) Compressor, heat pump stage 1 (type BW 351.B)
- (D) Premium tariff meter
- (E) Ripple control receiver (contact open: Power-OFF enabled)
- (F) Backup fuse, ripple control receiver
- (G) Feed: TNC system
- (H) Economy tariff meter
- (K) Compressor, heat pump stage 2 (type BWS 351.B)

Power supply with power-OFF: With on-site load disconnect

The power-OFF signal is connected to the on-site contactor of the economy tariff power supply and to the heat pump control unit. When power-OFF is enabled, the compressor and the instantaneous heating water heater (if installed) are "forced" off; in the 2-stage version (types BW + BWS) **both** compressors **and** the instantaneous heating water heater are switched off.

Note

Observe the technical connection conditions of the relevant power supply utility.

1-stage (type BW 351.B)

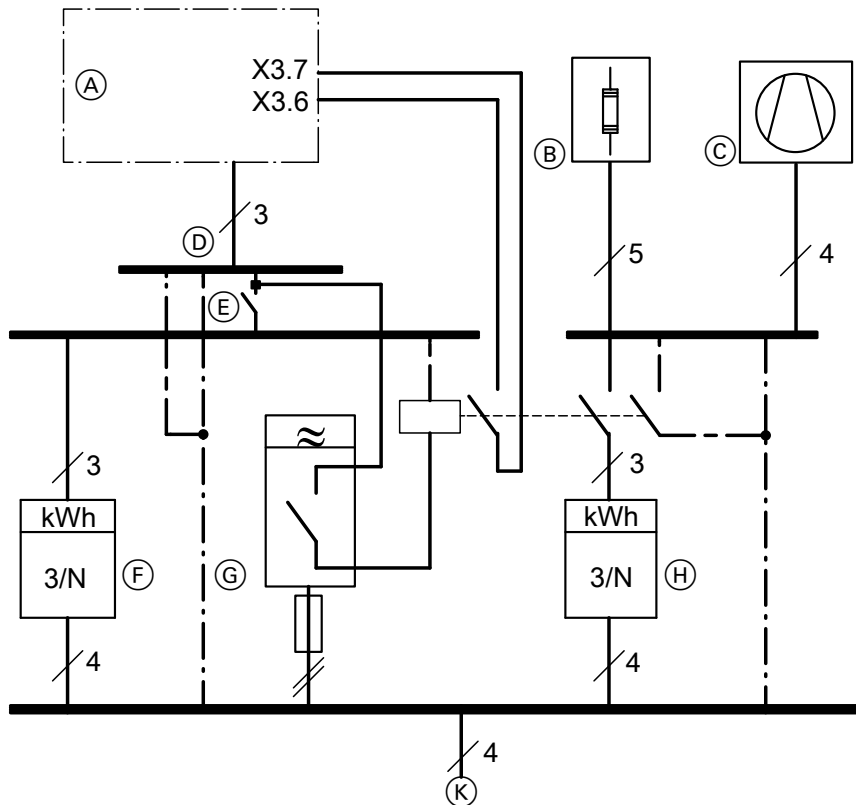

Fig. 26 Shown without fuses and RCDs

- | | |
|--|--|
| <ul style="list-style-type: none"> Ⓐ Heat pump control unit (connection on cross connect PCB) Ⓑ Instantaneous heating water heater (if installed) Ⓒ Compressor Ⓓ Control unit power supply Ⓔ Mains isolator | <ul style="list-style-type: none"> Ⓕ Premium tariff meter Ⓖ Ripple control receiver (contact open: Power-OFF enabled) with backup fuse Ⓗ Economy tariff meter Ⓚ Feed: TNC system |
|--|--|

Power supply (cont.)

2-stage (type BW 351.B + BWS 351.B)

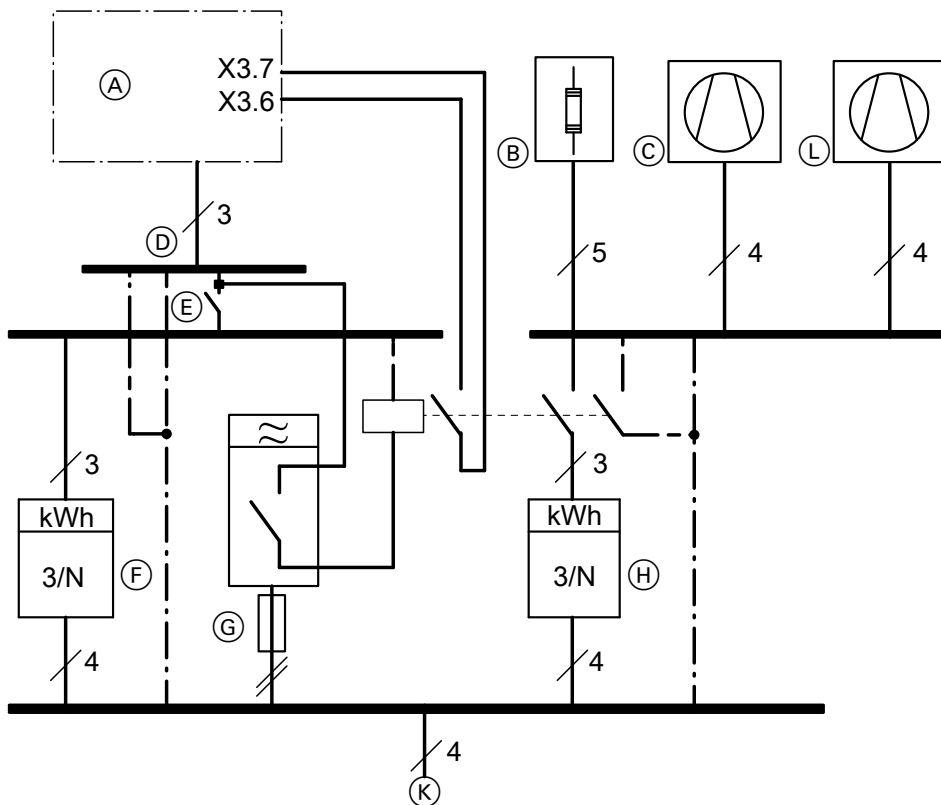

Fig. 27 Shown without fuses and RCDs

- | | |
|---|--|
| <ul style="list-style-type: none"> (A) Heat pump control unit (connection on cross connect PCB) (B) Instantaneous heating water heater (if installed) (C) Compressor, heat pump stage 1 (type BW 351.B) (D) Control unit power supply (E) Mains isolator | <ul style="list-style-type: none"> (F) Premium tariff meter (G) Ripple control receiver (contact open: Power-OFF enabled) with backup fuse (H) Economy tariff meter (K) Feed: TNC system (L) Compressor, heat pump stage 2 (type BWS 351.B) |
|---|--|

Mains power supply in conjunction with on-site power consumption

Without power-OFF

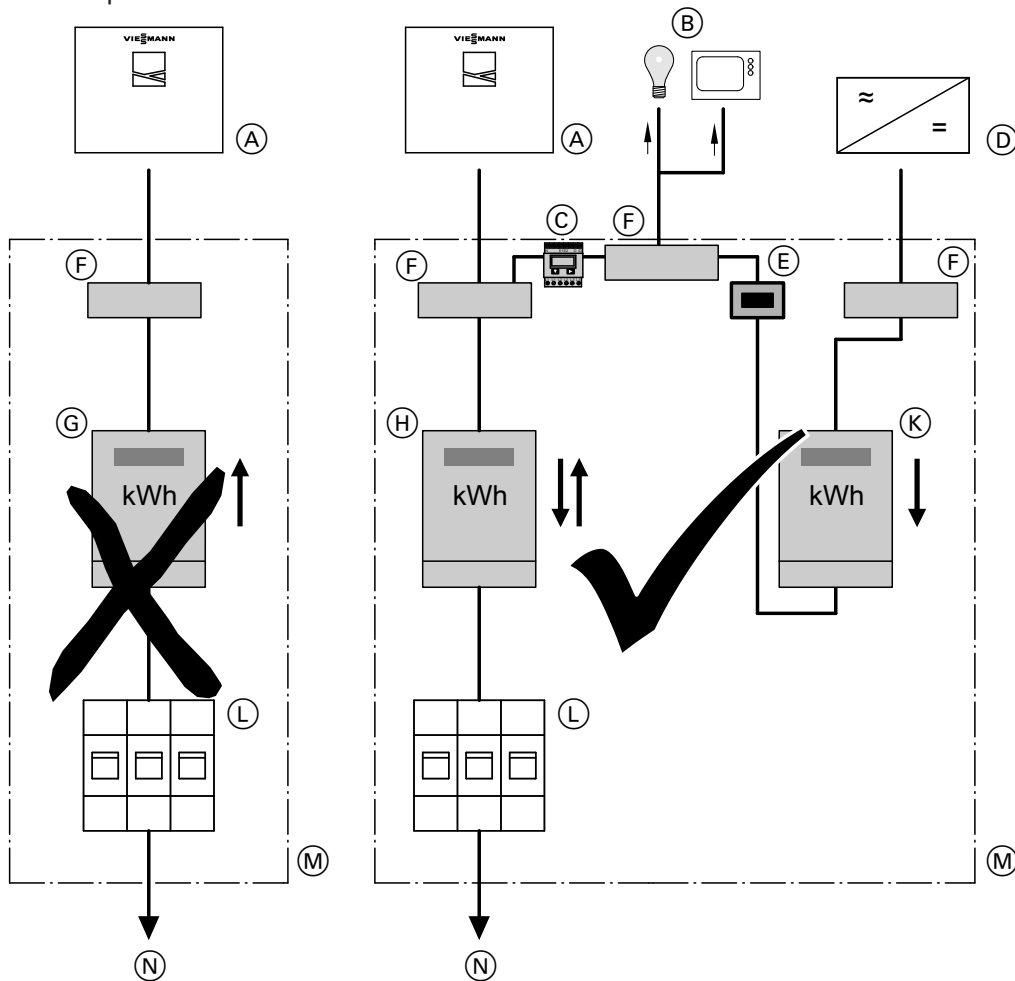

Fig. 28

- (A) Heat pump
- (B) Additional consumers (of power generated on site) in the household
- (C) Electricity meter
- (D) Inverter
- (E) Isolator for the PV system
- (F) Terminal
- (G) Double-tariff meter (for special tariff for heat pump) **Not permissible in conjunction with PV systems for on-site power consumption**
- (H) Bi-directional meter (for PV systems to consume power on site):
Energy taken from power supply utility and energy fed into power supply utility
- (K) Meter with reverse block:
For energy generated by PV system
- (L) Isolator for the domestic power supply connection (distribution panel)
- (M) Distribution panel
- (N) Domestic distribution box

Smart Grid

The Smart Grid functions are switched via the two PSU floating contacts.

Connection options for the two floating contacts:

- To EA1 extension as shown in Fig. 29
- To the heat pump control unit as shown in Fig. 30

Power supply (cont.)

Connection to EA1 extension

Condition: "Enable Smart Grid 7E80" must be at "1".

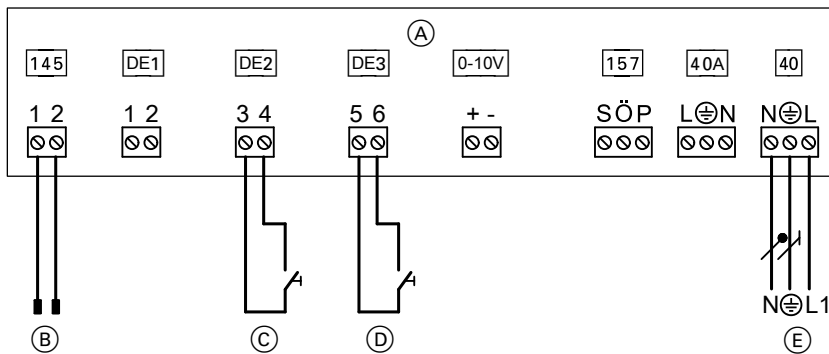

Fig. 29

- (A) EA1 extension
- (B) Connection to controller and sensor PCB
- (C) Floating N/O contact 1: The agreement of the power supply utility may be required

- (D) Floating N/O contact 2: The agreement of the power supply utility may be required
- (E) Power supply 1/N/PE 230 V/50 Hz

Note

- If Smart Grid is enabled ("Enable Smart Grid 7E80" set to "1"), both inputs DE2 and DE3 **cannot** be used for signals "External demand" or "External blocking".
- The power-OFF function is integral to Smart Grid. Therefore do **not** connect the power-OFF signal to terminals X3.6 and X3.7. Do **not** remove jumper.

Note

- If Smart Grid is connected to the two digital inputs on main PCB ("Enable Smart Grid 7E80" set to "4"), the external hook-up for the heating/cooling circuits must not be switched on ("Remote control 2003" set to "2"). Otherwise the Smart Grid will not be active.
- The power-OFF function is integral to Smart Grid. In this case, therefore, the power-OFF signal must **not** be connected to connections X3.6 and X3.7.

Connection to heat pump control unit

Condition: "Enable Smart Grid 7E80" must be at "4".

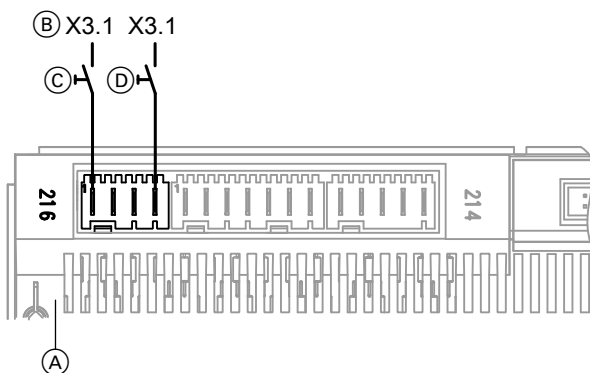

Fig. 30

- (A) Main PCB
- (B) Connection X3.1 (L') on the luster terminals
- (C) Floating contact 1: The agreement of the power supply utility may be required
- (D) Floating contact 2: The agreement of the power supply utility may be required

Phase monitor (if installed)

- The phase monitor monitors the compressor power supply.
- If the internal tolerance range is exceeded or undershot, the phase monitor interrupts the safety chain via a floating contact. The compressor switches off.
- The phase monitor automatically re-enables the compressor power supply if the values return to within the specified tolerance range. **No** reset required.

Note

If the phase monitor has responded, check the power supply and remove the cause of the fault.

Version 1

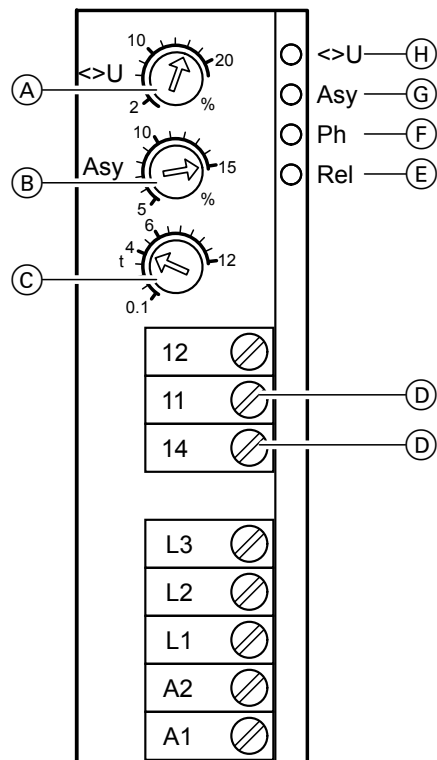

Fig. 31

- (A) Over/undervoltage in %
- (B) Phase asymmetry in %
- (C) Switching delay in s
- (D) Contact used in safety chain (N/O contact)
- (E) ON/OFF indicator ("Rel")
- (F) Fault indicator, phase failure/phase sequence "Ph"
- (G) Fault indicator, asymmetry "Asy"
- (H) Fault indicator, over/undervoltage " $\llcorner U$ "

LEDs explained in Fig. 31

- "Rel" illuminates green: All voltages and the rotating field (clockwise) are OK.
- "Ph" illuminates red: Relay has responded. Rotating field is anti-clockwise.
- All LEDs off: One or more phases have dropped out.
- " $\llcorner U$ " illuminates red: Incorrect voltage on one or more phases
- "Asy" illuminates red: Asymmetry on one or more phases

Version 2

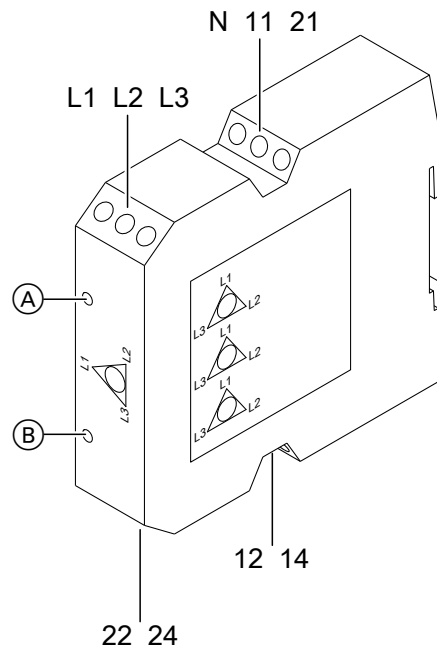

Fig. 32

LEDs explained in Fig. 32

- (A) Voltage "U":
 - Illuminates green if voltage is present.
- (B) Relay "R":
 - Illuminates yellow if the phase sequence is correct.
 - Does not illuminate if the phase sequence is incorrect.

Power supply (cont.)

Version 3

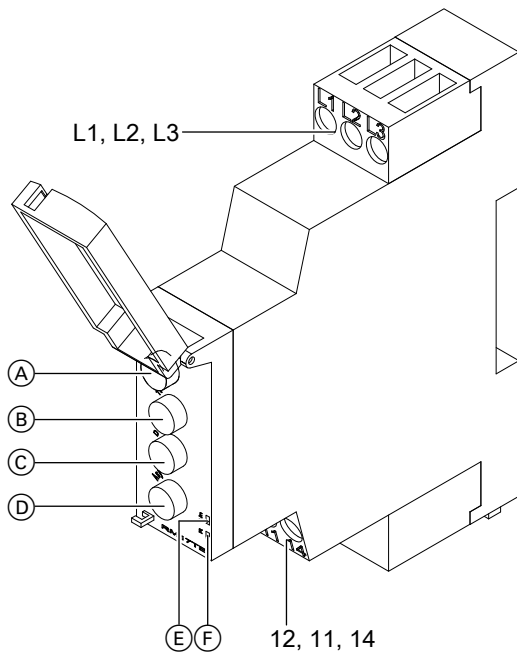

Fig. 33

- (A) Voltage range
- (B) Delay in s "Tt"
- (C) Over/undervoltage in % "ΔU"
- (D) Phase asymmetry in % "Asy"

LEDs explained in Fig. 33

- (E) Voltage "Un":
 - Illuminates green if voltage is present.
- (F) Relay "R":
 - Illuminates yellow if the phase sequence is correct.
 - Does not illuminate if the phase sequence is incorrect.
 - Flashes yellow during delay "Tt".

Make connections at terminals X3.8/X3.9

After connecting the power supply, one of the following components **must** be connected at terminals X3.8 and X3.9:

- Primary circuit pressure switch and/or frost stat
- or
- jumper supplied

Closing the heat pump

- ! **Please note**
Leaking hydraulic connections lead to appliance damage.
 - Check for leaks in the internal and on-site hydraulic connections.
 - In the event of leaks, switch off the appliance immediately. Drain liquid via the drain & fill valve. Check the seating of seal rings. **Always** replace displaced seal rings.

- ! **Please note**
If the casing is not securely sealed, this can lead to damage from condensate, vibrations and excessive noise.
 - Seal the casing door so it is soundproof and diffusion-proof.
 - The outer panels must be fitted so as to be diffusion-proof during operation. Only remove the outer panels for maintenance and service work.

Closing the heat pump (cont.)



Danger

The absence of system component earthing can lead to serious injury from electrical current and component damage in the event of an electrical fault.

All earth conductor connections **must** be reconnected.

The appliance and pipework must be connected to the equipotential bonding of the building.

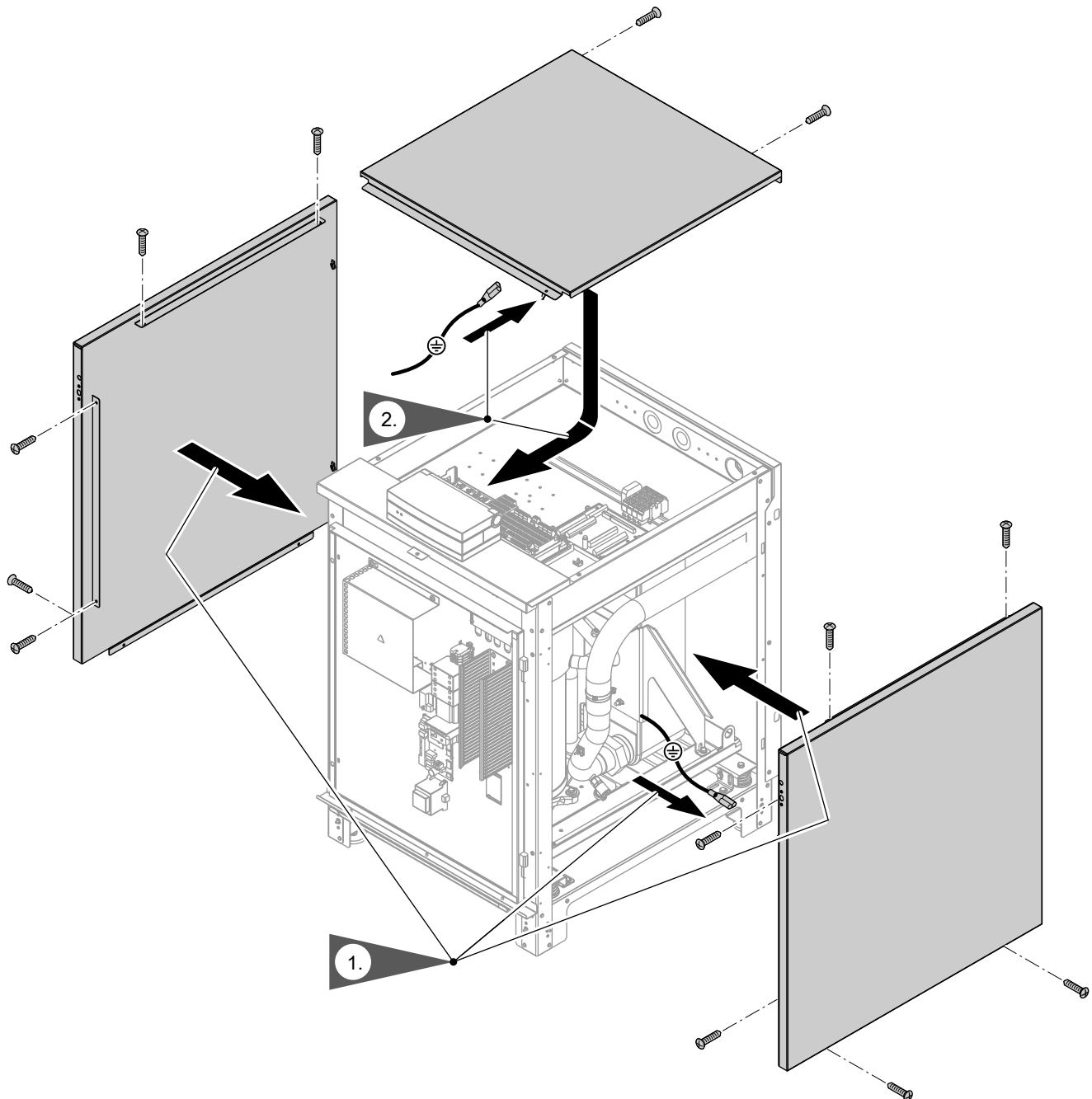

Fig. 34

Closing the heat pump (cont.)

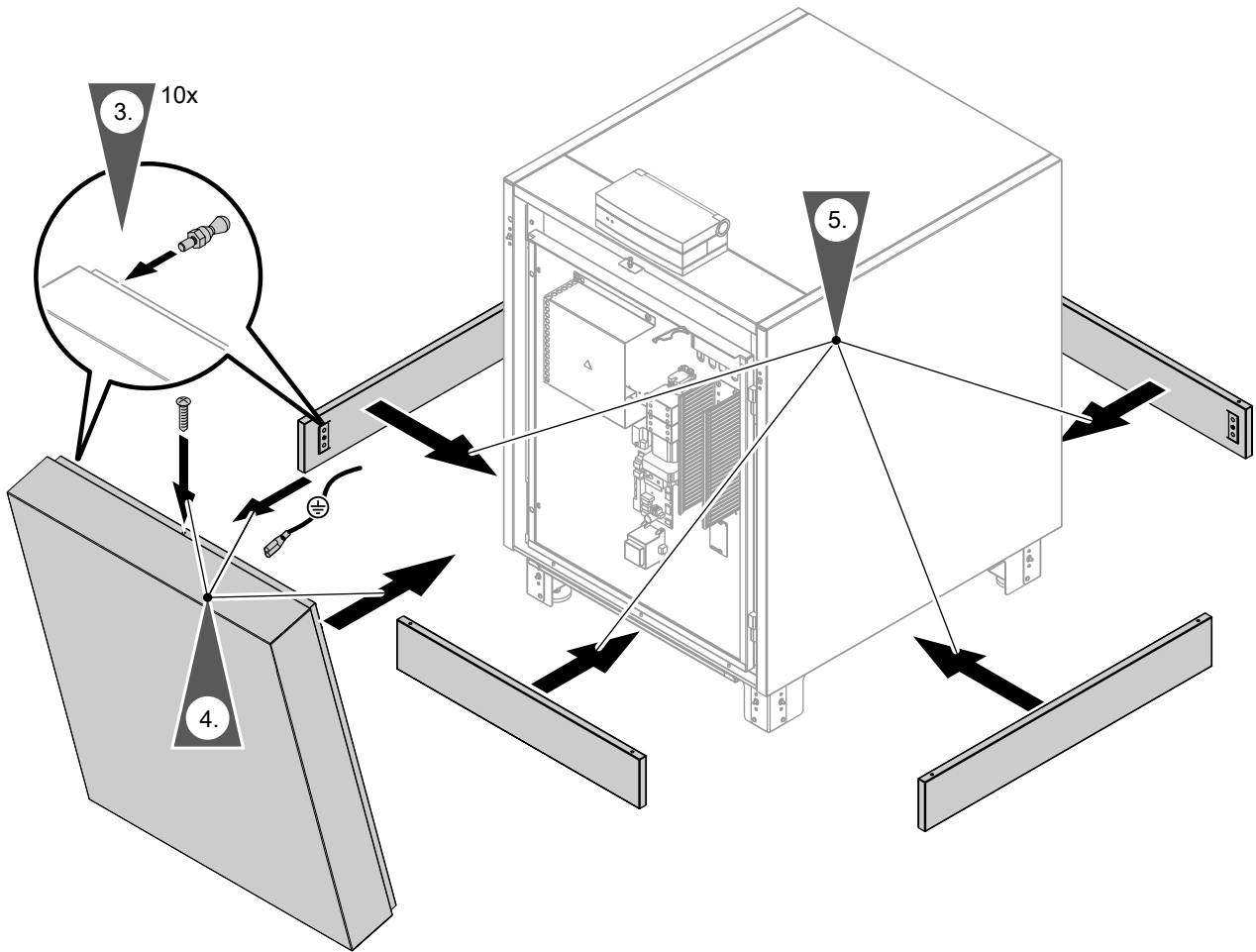

Fig. 35

Checking the diaphragm grommets

- !** **Please note**
- If the casing is not securely closed, this can lead to damage from condensation, vibrations and excessive noise.
 - Seal the appliance so it is soundproof and diffusion-proof.
 - Ensure the diaphragm grommets at the hose outlets are seated correctly. Seal hose outlets with sealing tape if necessary.

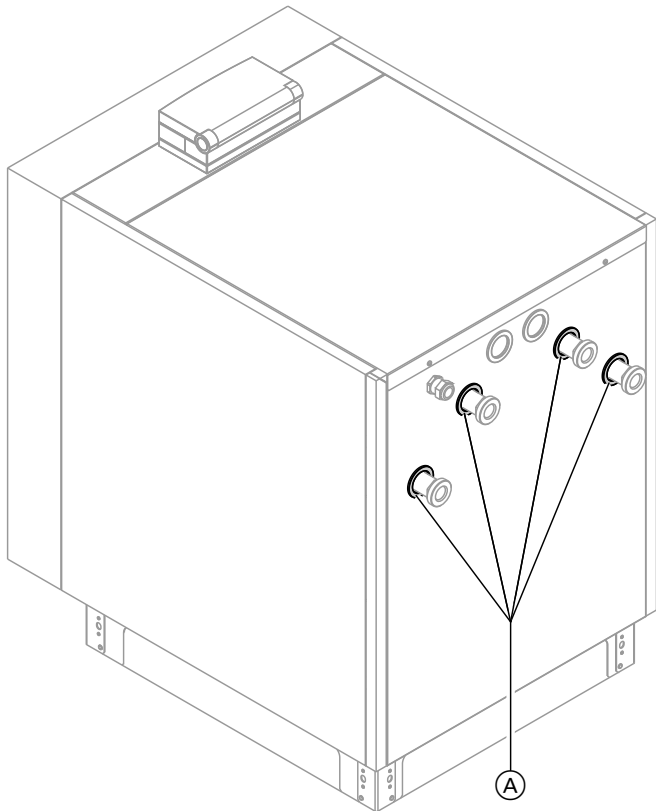

Fig. 36

Ⓐ Diaphragm grommets



Steps - commissioning, inspection and maintenance

	Commissioning steps		
	Inspection steps		
	Maintenance steps		
			Page
•	•	•	1. Opening the heat pump 49
•			2. Compiling reports 50
•	•	•	3. Checking the refrigerant circuit for leaks 50
•			4. Filling and venting the primary side 50
•			5. Filling and venting the secondary side 51
•	•	•	6. Checking expansion vessels and the primary circuit/heating circuit pressure 51
•	•	•	7. Checking the electrical connections for firm seating
•			8. Commissioning the system 51
•	•	•	9. Closing the heat pump 63
•	•	•	10. Checking the heat pump for noise 63
•	•	•	11. Checking the system function 63
•			12. Instructing the system user 63



Opening the heat pump



Danger

Contact with live components can lead to serious injury from electric current.

- **Never touch** wiring chambers: For heat pump control unit and power supplies, see page 23.
- When working on the appliance, isolate the system from the power supply, e.g. at a separate MCB/fuse or a mains isolator. Check that it is no longer live. Safeguard against reconnection.



Danger

The absence of component earthing can lead to serious injury from electrical current and cause component damage in the event of an electrical fault.

All earth connectors **must** be reconnected.



Please note

Commissioning immediately after installation can lead to appliance damage.

Wait **at least 30 min** between installing and commissioning the appliance.

1. Remove the front panel in reverse order to the description on page 45.





Opening the heat pump (cont.)

- When work is complete, close the heat pump: See page 45.



Commissioning the appliance

Operating instructions for "Vitotronic 200 heat pump control unit"



Compiling reports

Enter all readings taken during commissioning (described below) in the reports on page 73 onwards.



Checking the refrigerant circuit for leaks



Danger

The refrigerant is a non-poisonous gas that displaces air. Unregulated escape of refrigerant in enclosed spaces can lead to breathing difficulties and suffocation.

- Ensure adequate ventilation in enclosed spaces.
- Always observe regulations and guidelines on handling this type of refrigerant.



Please note

Refrigerant can escape when working on the refrigerant circuit.

Work on the refrigerant circuit must **only** be carried out by a certified contractor (in accordance with EC 842/2006 and 303/2008).



Danger

Direct contact with refrigerant can be harmful to skin.

Wear safety goggles and protective gloves when working on the refrigerant circuit.

Check the floor area, valves and all visible solder joints for traces of oil.

Note

Traces of oil indicate a leak in the refrigerant circuit. Have your heat pump checked over by a refrigeration engineer.



Filling and venting the primary side



Please note

Commissioning when the primary circuit is empty causes appliance damage. Charge and vent the primary circuit before connecting the power supply.

- Check the pre-charge pressure of the expansion vessel.

- Charge the primary circuit with Viessmann heat transfer medium and vent.

Note

Ensure frost protection down to $-19\text{ }^{\circ}\text{C}$.

Viessmann heat transfer medium is a ready-mixed ethylene glycol-based medium. It contains inhibitors for corrosion protection. The heat transfer medium can be used at temperatures down to $-19\text{ }^{\circ}\text{C}$.



Filling and venting the primary side (cont.)

3. Check the connections for possible leaks. Replace faulty or displaced gaskets.



Filling and venting the secondary side

Unsuitable fill and top-up water increases the level of deposits and corrosion. This can lead to system damage.

Observe VDI 2035 regarding quality and amount of heating water, including fill and top-up water.



Please note

- Escaping liquids can lead to electrical defects. Protect electrical components of the heat pump from escaping liquids.

Note

Before filling the system, observe VDI 2035 sheet 1.

1. Open any on-site non-return valves if installed.
2. Check the pre-charge pressure of the expansion vessel.
3. Fill (flush) and vent the secondary circuit.

- Flush the heating system thoroughly before filling.
- Only fill with water of potable quality.
- If the fill and top-up water has a water hardness greater than 16.8 °dH (3.0 mol/m³), it must be softened, e.g. using the small softening system for heating water: See the Vitoset pricelist.



Please note

- Leaking hydraulic connections lead to appliance damage.
 - Check for leaks in the internal and on-site hydraulic connections.
 - In the event of leaks, switch off the appliance immediately. Drain off liquid via the drain valve. Check the seating of seal rings. **Always** replace displaced seal rings.
- 5. Check system pressure. Top up with water if required.
 - Minimum system pressure: 0.8 bar (80 kPa)
 - Permiss. operating pressure: 2.5 bar (250 kPa)



Checking expansion vessels and the primary circuit/heating circuit pressure



Observe engineering information.

Technical guides for heat pumps



Checking the electrical connections for firm seating



Commissioning the system

Commissioning (configuration, parameter settings and function check) can be carried out with or without the commissioning wizard (see following chapter and service instructions for the heat pump control unit).

Note

The type and extent of the parameters depend on the appliance type, on the selected system scheme and the accessories employed.

Starting the heat pump

Switch ON the system power supply, e.g. at the separate MCB/fuse or at a mains isolator.



Commissioning with the commissioning assistant

The commissioning assistant automatically guides you through all the menus where settings have to be made. For this, "Coding level 1" is automatically active.

- ! Please note**

Incorrect operation at "Coding level 1" may result in damage to the appliance and the heating system. Observe the service instructions for the "Vitotronic 200", otherwise the appliance warranty will be void.

Switch ON the ON/OFF switch on the control unit.

- The prompt "**Start commissioning?**" appears **automatically** on commissioning.

Note

The commissioning assistant can also be started manually:

To do this, press and hold  when switching on the control unit (progress bar visible).

- When the unit is first commissioned, the display is in German.



Fig. 37

- Manually switching some appliance components during commissioning enables the control unit to display messages. These messages are not appliance faults.





Commissioning the system (cont.)

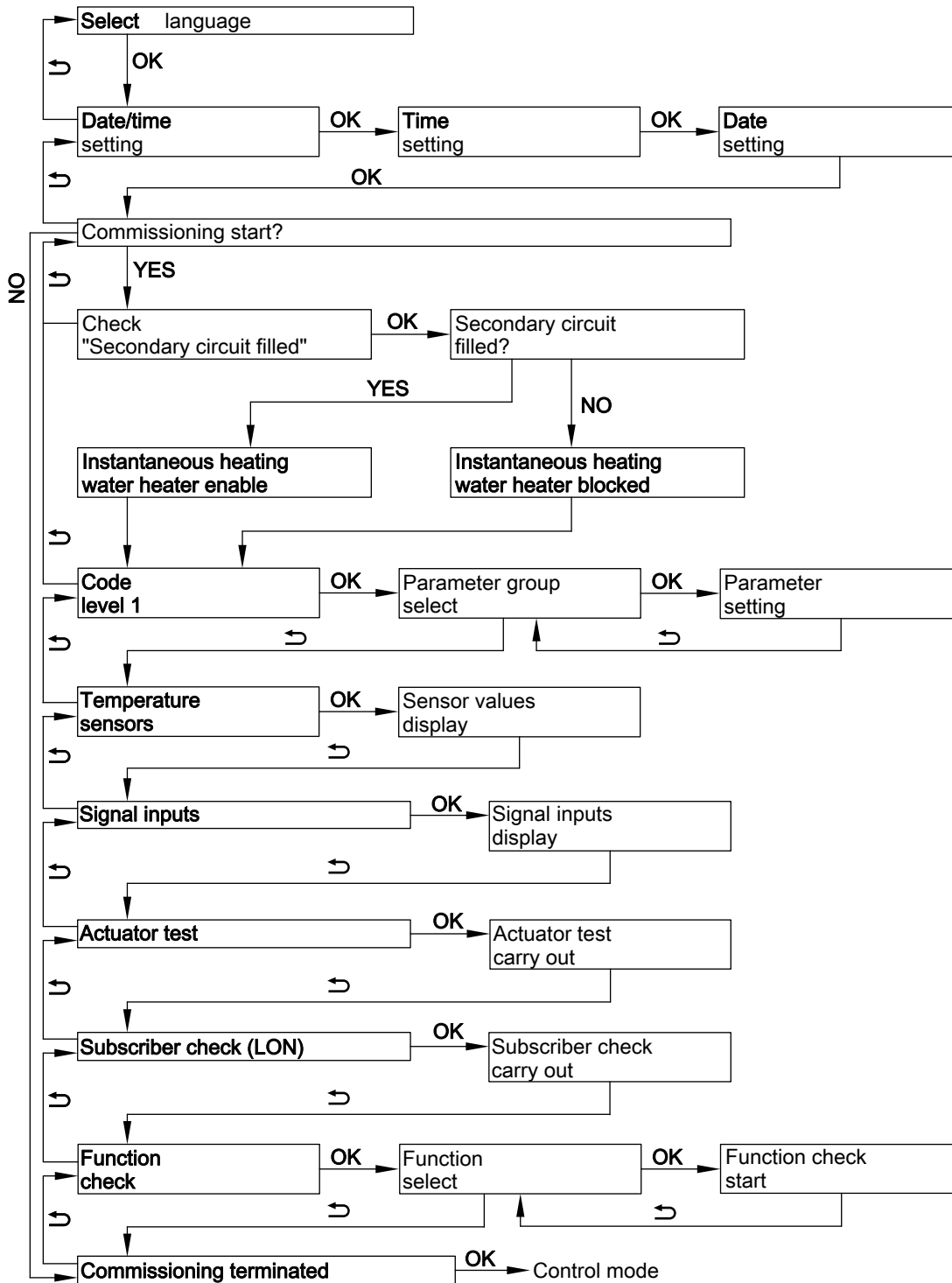

Fig. 38

Commissioning without the commissioning assistant

Activating the service menu

The service menu can be activated from any other menu.
 Press and hold **OK** + **≡** simultaneously for approx. 4 s.

Deactivating the service menu

The service menu remains active until it is disabled with **"Terminate service?"**, or if no key is pressed for 30 min.



Setting parameters using "System scheme 7000" as an example

To set a parameter, first select the parameter group and then the parameter.

Service menu:

1. Press and hold **OK** + simultaneously for approx. 4 s.
2. Select **"Coding level 1"**.
3. Select parameter group: **"System definition"**
4. Select parameter: **"System scheme 7000"**
5. Set a system scheme: e.g. **"6"**

Alternatively, if the service menu was already active:

Extended menu:

- 1.
2. **"Service"**
3. Select **"Coding level 1"**.
4. Select parameter group: **"System definition"**
5. Select parameter: **"System scheme 7000"**
6. Set a system scheme: e.g. **"6"**

Required parameters for components connected on site

Parameters may need to be set subject to the appliance type, the selected system scheme and the accessories used.

Detailed explanations of parameters
"Vitotronic 200" service instructions

Overview of required parameters: See the following chapter.

System scheme

System schemes

Component	System scheme											
	0	1	2	3	4	5	6	7	8	9	10	11
Heating circuit												
A1/HC1	—	X	X	—	—	X	X	—	—	X	X	—
M2/HC2	—	—	—	X	X	X	X	X	X	X	X	—
M3/HC3	—	—	—	—	—	—	—	X	X	X	X	—
DHW cylinder	X	—	X	—	X	—	X	—	X	—	X	—
Immersion heater	○	—	○	—	○	—	○	—	○	—	○	—
Heating water buffer cylinder	—	○	○	X	X	X	X	X	X	X	X	—
External heat generator	○	○ ^{*1}	○ ^{*1}	○	○	○	○	○	○	○	○	—
Instantaneous heating water heater	○	○	○	○	○	○	○	○	○	○	○	○
Swimming pool	—	○	○	○	○	○	○	○	○	○	○	—
Solar thermal system	○	—	○	—	○	—	○	—	○	—	○	—
Cooling												
A1/HC1	—	○	○	—	—	○	○	—	—	○	○	—
M2/HC2	—	—	—	○	○	○	○	○	○	○	○	—
M3/HC3	—	—	—	—	—	—	—	○	○	○	○	—
Separate cooling circuit SKK	○	○	○	○	○	○	○	○	○	○	○	—
Coolant buffer cylinder	○	○	○	○	○	○	○	○	○	○	○	—

^{*1} Only in conjunction with a heating water buffer cylinder.



Commissioning the system (cont.)

Component	System scheme											
	0	1	2	3	4	5	6	7	8	9	10	11
Ice store and solar air absorber	<input type="radio"/>	<input type="radio"/>	<input type="radio"/>	<input type="radio"/>	<input type="radio"/>	<input type="radio"/>	<input type="radio"/>	<input type="radio"/>	<input type="radio"/>	<input type="radio"/>	<input type="radio"/>	<input type="radio"/>
Energy meter	<input type="radio"/>	<input type="radio"/>	<input type="radio"/>	<input type="radio"/>	<input type="radio"/>	<input type="radio"/>	<input type="radio"/>	<input type="radio"/>	<input type="radio"/>	<input type="radio"/>	<input type="radio"/>	—
Ventilation unit	<input type="radio"/>	<input type="radio"/>	<input type="radio"/>	<input type="radio"/>	<input type="radio"/>	<input type="radio"/>	<input type="radio"/>	<input type="radio"/>	<input type="radio"/>	<input type="radio"/>	<input type="radio"/>	—

- X Component selected
 O Component can be added

For detailed information on system examples: See www.viessmann-schemes.com.

Parameters for circulation pumps and other components

Heating circuit pump

Parameter	Setting
"System definition" →	
"System scheme 7000"	<ul style="list-style-type: none"> ▪ With heating circuit A1/HC1 without mixer or ▪ With heating circuit M2/HC2 with mixer or ▪ With heating circuit M3/HC3 with mixer

Circulation pump for cylinder heating

Parameter	Setting
"System definition" →	
"System scheme 7000"	With DHW heating

DHW circulation pump

Parameter	Setting
Extended menu →	
"Time program DHW circulation"	Set a time program.

Circulation pump for DHW reheating

Parameter	Setting
"External heat source" →	
"Enable external heat source 7B00"	"1"
"Enable external heat source for DHW heating 7B0D"	"1"

Mixer extension kit for heating circuit M3/HC3

Parameter	Setting
"System definition" →	
"System scheme 7000"	With heating circuit M3/HC3 Note Set rotary switch S1 in the extension kit to "2": See "Mixer extension kit" installation instructions.



Remote control for heating/cooling circuit or Vitocomfort 200

Parameter	Setting
"Heating circuit 1"/"Heating circuit 2"/"Heating circuit 3" →	
"Remote control 2003" or "Remote control 3003" or "Remote control 4003"	"1" Note <i>To assign a heating circuit, set the code at the remote control: See "Vitolrol" installation instructions.</i>

Vitocom 100, type GSM2

Parameter	Setting
"System definition" →	
"Vitocom 100 7017"	"1"

External extension

Parameter	Setting
"System definition" →	
"External extension 7010"	"1" EA1 extension "2" AM1 extension "3" EA1 and AM1 extensions Note <i>For parameters for external functions, see the following table.</i>

Heat pump stage 2

Parameter	Setting
"Compressor 2" →	
"Enable compressor 5100"	"1"
"Output compressor stage 5130"	Value corresponding to the rated heating output of heat pump stage 2: See type plate.

Parameters for external functions

External demand

Parameter	Setting
"Internal hydraulics" → if necessary	
"Flow temperature external demand 730C"	Set flow temperature for external demand

External starting of the compressor; mixer in control mode or OPEN

Parameter	Setting
"System definition" →	
"Effect of external demand on heat pump/heating circuits 7014"	"0" to "7" (Observe parameter "Flow temperature external demand 730C")



Commissioning the system (cont.)

External changeover of the operating status of various system components

Parameter	Setting
"System definition" →	
"System components for external changeover 7011"	"0" to "127"
"Operating status for external changeover 7012"	"0" to "3"
"Duration of external changeover 7013"	"0" to "12"

External blocking of compressor and pumps

Parameter	Setting
"System definition" →	
"Effect of external blocking on pumps/compressor 701A"	"0" to "31"

External blocking of the compressor; mixer in control mode or CLOSED

Parameter	Setting
"System definition" →	
"Effect of ext. blocking on heat pump/heating circuits 7015"	"0" to "8"
"Effect of external blocking on pumps/compressor 701A"	"0" to "31"

External hook-up for heating/cooling circuits

Parameter	Setting
"Heating circuit 1"/"Heating circuit 2"/"Heating circuit 3" →	
"Remote control 2003" or "Remote control 3003" or "Remote control 4003"	"2"

Note

If heat pump stage 2 is connected, the external hook-up for heating/cooling circuits is not possible.

Cooling function parameters

Parameter	Setting
"Cooling" →	
"Cooling function 7100"	"0" No cooling "1" Natural cooling with NC-Box without mixer (accessory) "2" Natural cooling with NC-Box with mixer (accessory) "3" "Active cooling"
"Cooling circuit 7101"	"1" Heating circuit A1/HC1 "2" Heating circuit M2/HC2 "3" Heating circuit M3/HC3 "4" Separate cooling circuit SKK

Room temperature sensor for separate cooling circuit

Parameter	Setting
"Cooling" →	
"Ranking room temp sensor separate cooling circuit 7106"	"0" Connection F16 "1" Heating circuit A1/HC1 "2" Heating circuit M2/HC2 "3" Heating circuit M3/HC3 "4" Do not adjust.



Parameters for solar DHW heating

Parameters in conjunction with solar control module type SM1	Setting
"Solar" →	
"Type solar control unit 7A00"	"3"
Parameter C0xx	See installation and service instructions for "Solar control module, type SM1".

Parameters for instantaneous heating water heater

Parameter	Setting
"Electr booster heater" →	
"Enable instantaneous heating water heater 7900"	"1"
"Output for instant. heating water heater at power-OFF 790A"	"1" 3 kW "2" 6 kW "3" 9 kW

! **Please note**
After the value "1" has been set for **"Enable instantaneous heating water heater 7900"**, the prompt **"Secondary circuit filled?"** automatically appears. If this prompt is responded to with **"No"**, the instantaneous heating water heater will not be enabled. Set **"Enable instantaneous heating water heater 7900"** to **"2"**. Fill the secondary circuit. Confirm prompt **"Secondary circuit filled?"** with **"Yes"**.

Enable instantaneous heating water heater for DHW heating

Parameter	Setting
"DHW" →	
"Enable electric heaters for DHW heating 6015"	"1"

Parameters for external heat generators

Parameter	Setting
"External heat source" →	
"Enable external heat source 7B00"	"1"

Enable external heat source for DHW heating

Parameter	Setting
"External heat source" →	
"Enable external heat source for DHW heating 7B0D"	"1"

Parameters for immersion heater

Parameters	Setting
"DHW" →	
"Enable electric heaters for DHW heating 6015"	"1"
"Enable booster heaters for DHW heating 6014"	"1"



Commissioning the system (cont.)

Parameters for swimming pool water heating

Parameter	Setting
"System definition" →	
"External extension 7010"	"1" or "3"
"Swimming pool 7008"	"1"

Parameters for ice store system

Parameter	Setting
"System definition" →	
"Select primary source 7030"	"1"
"External extension 7010"	"2"

Parameter	Setting
"Solar" →	
"Type solar control unit 7A00"	"2"

Possibly set additional parameters.

Parameter	Setting
"System definition" →	
"Start hysteresis solar air absorber 7031"	"0" to "500" (\pm 0 to 50 K)
"Min. runtime to suppress summer mode 7035"	"0" to "1440" min
"Last calendar week for summer mode 7036"	Calendar week "1" to "53"

Parameters for ventilation with Vitovent 200-C

Parameter	Setting
"Ventilation" →	
"Vitovent enable 7D00"	"2" Vitovent 200-C

Further enabling for Vitovent 200-C if necessary

Parameter	Setting
"Ventilation" →	
"Enable preheater bank electric 7D01"	"0" Defrosting without preheating coil ("Strategy, passive frost protection 7D2C") "1" Frost protection with preheating coil; defrosting via bypass "2" Frost protection with preheating coil; comfort function
"Strategy, passive frost protection 7D2C"	"0" Fans OFF "1" Defrosting via bypass "2" Supply air fan OFF
"Type of heat exchanger 7D2E"	"0" Countercurrent heat exchanger "1" Enthalpy heat exchanger
"Installation position 7D2F"	"0" Ceiling mounting "1" Wall mounting
"Function, external 230 V input, ventilation 7D3A"	"1" External switch (bathroom switch) enabled



Adjust values for Vitovent 200-C if necessary

Parameter	Setting
"Ventilation" →	
"Set room temperature 7D08"	"100" to "300" (± 10 to 30 °C)
"Flow rate reduced ventilation 7D0A"	Subject to sizing  Ventilation unit service instructions
"Flow rate nominal ventilation 7D0B"	
"Flow rate intensive ventilation 7D0C"	

Parameters for ventilation with Vitovent 200-W/300-C/300-W

Parameter	Setting
"Ventilation" →	
"Vitovent enable 7D00"	"3" Vitovent 200-W or Vitovent 300-C or Vitovent 300-W

Adjust values for Vitovent 200-W/300-C/300-W if necessary

Parameter	Setting
"Ventilation" →	
"Set room temperature C108"	Max. 4 K higher or lower than " Standard room temperature 2000 " (adjustment value: 1 ± 0.1 °C)
"Background ventilation C109"	Subject to sizing  Ventilation unit service instructions
"Reduced ventilation C10A"	
"Standard ventilation C10B"	
"Intensive ventilation C10C"	
"Background ventilation, second fan duct C189" (Vitovent 200-W only)	
"Reduced ventilation, second fan duct C18A" (Vitovent 200-W only)	
"Standard ventilation, second fan duct C18B" (Vitovent 200-W only)	
"Intensive ventilation, second fan duct C18C" (Vitovent 200-W only)	

Parameters for ventilation with Vitovent 300-F

Parameter	Setting
"Ventilation" →	
"Vitovent enable 7D00"	"1" Vitovent 300-F



Commissioning the system (cont.)

Further enabling for Vitovent 300-F if necessary

Parameter	Setting
"Ventilation" →	
"Enable preheater bank electric 7D01"	"1"
"Enable reheater bank hydraulic 7D02"	"1"
"Enable humidity sensor 7D05"	"1"
"Enable CO2 sensor 7D06"	"1"
"Type of heat exchanger 7D2E"	"0" Countercurrent heat exchanger "1" Enthalpy heat exchanger

Adjust values for Vitovent 300-F if necessary

Parameter	Setting
"Ventilation" →	
"Set room temperature 7D08"	"100" to "300" (± 10 to 30 °C)
"Flow rate reduced ventilation 7D0A"	Subject to sizing  Ventilation unit service instructions
"Flow rate nominal ventilation 7D0B"	
"Flow rate intensive ventilation 7D0C"	

Parameters for utilisation of power generated on site

Parameter	Setting
"Photovoltaics" →	
"Enable own energy consumption PV 7E00"	"1"
"Threshold for electrical power 7E04"	"0" to "300" (± 0 to 30 kW)

Enable required functions for utilisation of power generated on site

Parameter	Setting
"Photovoltaics" →	
"Enable own energy consumption for set DHW temperature 2 7E10"	"1"
"Enable own energy consumption for DHW heating 7E11"	"1"
"Enable own energy consumption for heating water buffer cyl. 7E12"	"1"
"Enable own energy consumption for heating 7E13"	"1"
"Enable own energy consumption for cooling 7E15"	"1"
"Enable own energy consumption for coolant buffer cylinder 7E16"	"1"

Specify the temperature differential to the selected set value for the chosen function

Parameter	Setting
"Photovoltaics" →	
"Raise set DHW cylinder temperature PV 7E21"	"0" to "500" (± 0 to 50 K)
"Raise set heating water buffer cylinder temp PV 7E22"	"0" to "400" (± 0 to 40 K)
"Raise set room temperature PV 7E23"	"0" to "100" (± 0 to 10 K)
"Reduce set room temperature PV 7E25"	"0" to "100" (± 0 to 10 K)
"Reduce set coolant buffer cylinder temperature PV 7E26"	"0" to "100" (± 0 to 10 K)



Parameters for Smart Grid

Parameter	Setting
"Smart Grid" →	
"Enable Smart Grid 7E80"	"1" Connection to EA1 extension "4" Connection to heat pump control unit
"Smart Grid Enable elec heat 7E82"	"1" Stage 1 "2" Stage 2 "3" Stage 3

Specify the temperature differential to the selected set value for the chosen function

Parameter	Setting
"Smart Grid" →	
"Smart Grid set value increase for DHW heating 7E91"	"0" to "500" (\cong 0 to 50 K)
"Smart Grid set value increase for htg wtr buff 7E92"	"0" to "400" (\cong 0 to 40 K)
"Smart Grid set value increase for centr htg 7E93"	"0" to "100" (\cong 0 to 10 K)
"Smart Grid set value decrease for room t cool 7E95"	"0" to "100" (\cong 0 to 10 K)

Parameters for heat pump cascade

Parameter	Setting	
	Lead heat pump	Lag heat pump
"Compressor" →		
"Enable use of compressor stage 5012"	"0" to "15"	—
"System definition" →		
"System scheme 7000"	"0" to "10"	"11"
"Cascade control 700A"	"2"	"0"
"Use of heat pump in cascade 700C"	—	"0" to "15"
"Number of lag heat pumps 7029"	"1" to "4"	—
"Internal hydraulics" →		
"Enable 3-way diverter valve heating/DHW 730D"	"0" or "1"	"0" or "1"
"Communication" →		
"Enable LON communication module 7710"	"1"	"1"
"Number of heat pump in cascade 7707"	—	"1" to "4"
"LON system number 7798"	"1" to "5"	"1" to "5"
"LON subscriber number 7777" Each number can only be allocated once.	"1" to "99"	"1" to "99"
"LON fault manager 7779" Only one control unit per system may be configured as the fault manager.	"0" or "1"	"0" or "1"
"Source time 77FE"	"0"	"1"
"Send time 77FF"	"1"	"0"
"Source outside temperature 77FC"	"0"	"1"
"Send outside temperature 77FD"	"1"	"0"
"Interval for data transfer via LON 779C"	"20"	"20"
"Buffer cylinder" →		
"Enable buffer cylinder/low loss header 7200"	"1"	—



Commissioning the system (cont.)

Parameter	Setting	
	Lead heat pump	Lag heat pump
"Electric heater" →		
"Enable instantaneous heating water heater 7900"	"0" or "1"	"0" or "1"
"Enable electric heaters for DHW heating 6015"	"0" or "1"	—
"Enable electric heaters for DHW heating 7901"	—	"0" or "1"
"Enable instant. heating water heater for central heating 7902"	"0" or "1"	"0" or "1"



Closing the heat pump

See page 45.



Checking the heat pump for noise

Checking the appliance for unusual noises, e.g. operating noise of compressor and pumps. Venting again if required.



Checking the system function

- Check the function of all system components: See **"Function check"**.
- Call up temperatures at the heat pump control unit.

"Function check" at the heat pump control unit

1. Service menu:

Press **OK** + simultaneously and hold for approx. 4 s.

2. "Service functions"

3. "Function check"

4. Start the required function, e.g. **"DHW"**. Only those functions are shown that correspond to the actual system equipment level. During the function check, the system overview is displayed.

5. Terminate function with .



Overview of functions

"Vitotronic 200" service instructions



Instructing the system user

The system installer should hand the operating instructions to the system user and instruct the user in operating the system.

This includes all components installed as accessories, e.g. remote control units. In addition, the system installer must make the user aware of the required maintenance work.

Overview of wiring chamber

Type BW 351.B

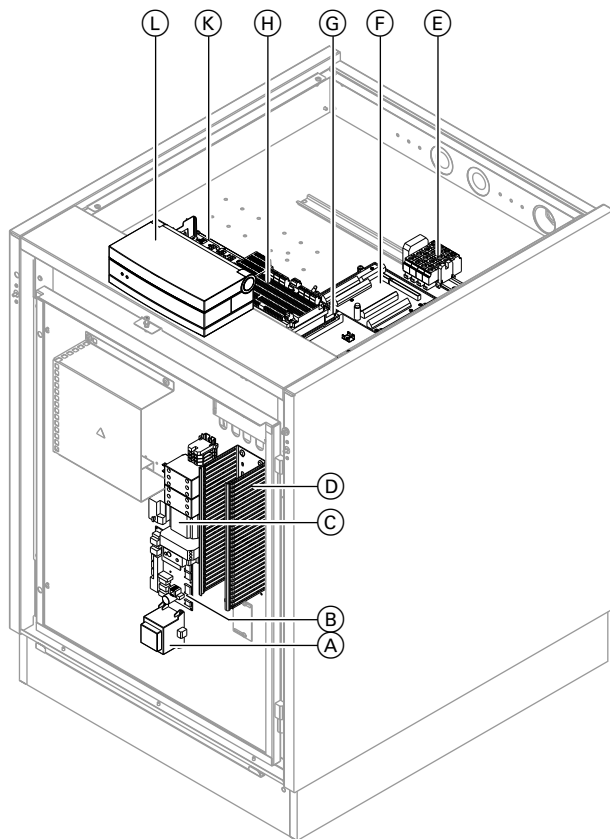

Fig. 39

- (A) Transformer, EEV PCB
- (B) EEV PCB (refrigerant circuit controller)
- (C) Compressor contactors, starter control, phase monitor
- (D) Cable channel
- (E) Compressor power supply
- (F) Cross connect PCB
- (G) Main PCB
- (H) Expansion PCB on the main PCB
- (K) Controller and sensor PCB
- (L) Programming unit

Type BWS 351.B

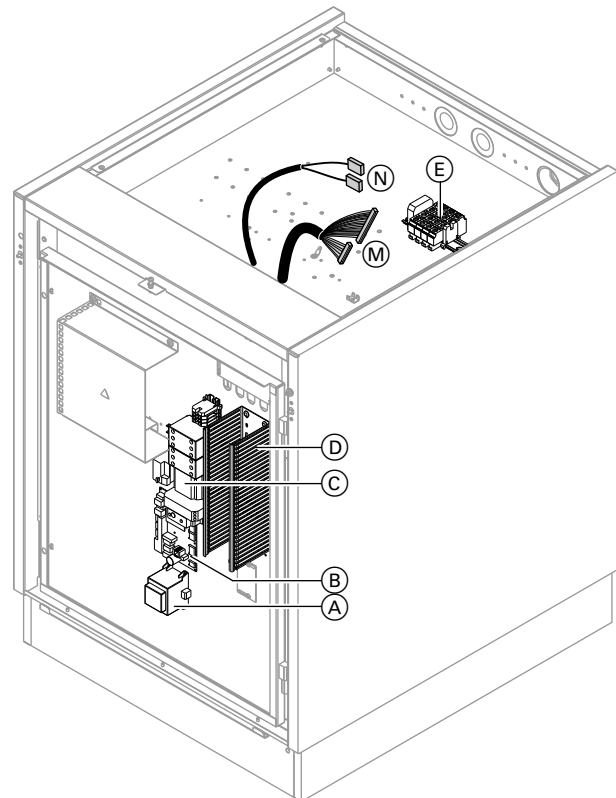

Fig. 40

- (A) Transformer, EEV PCB
- (B) EEV PCB (refrigerant circuit controller)
- (C) Compressor contactors, starter control, phase monitor
- (D) Cable channel
- (E) Compressor power supply
- (M) Plug for connecting cable, heat pump stage 1 – stage 2 230 V~
- (N) Plug for connecting cable, heat pump stage 1 – stage 2, extra low voltage (ELV)

Opening the casing door

To open the casing door: See "Removing the heat pump module" on page 70.

Overview of internal components

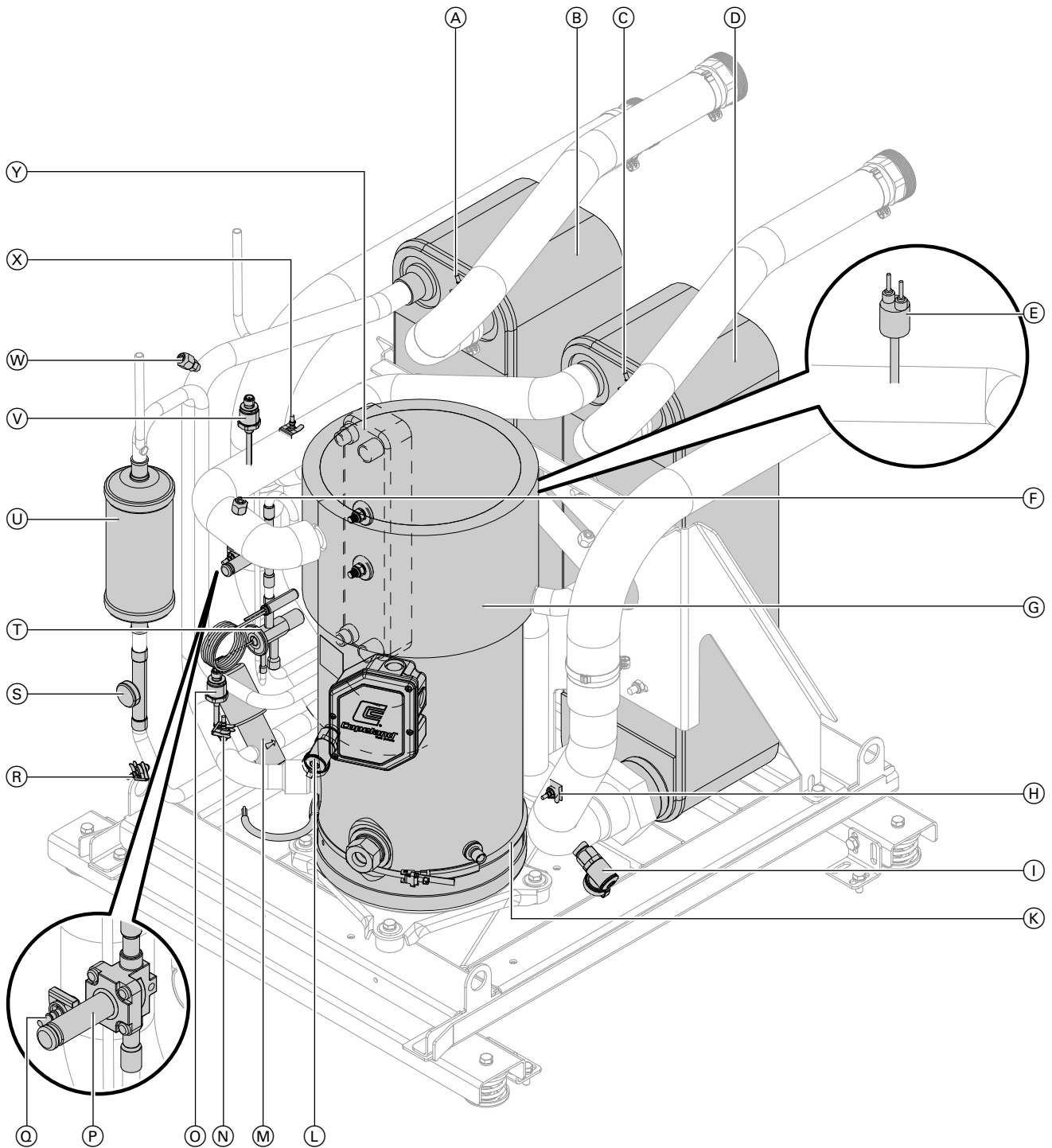

Fig. 41

- (A) Flow temperature sensor, primary circuit (heat pump brine inlet)
- (B) Evaporator
- (C) Secondary circuit flow temperature sensor
- (D) Condenser
- (E) Safety high pressure switch
- (F) Schrader valve, high pressure side
- (G) Compressor
- (H) Return temperature sensor, secondary circuit
- (I) Drain valve, secondary side
- (K) Oil sump heater
- (L) Drain valve, primary side
- (M) Electronic expansion valve
- (N) Suction gas temperature sensor
- (O) Low pressure sensor
- (P) Solenoid valve, vapour injection
- (Q) Return temperature sensor, primary circuit (heat pump brine outlet)
- (R) Liquid gas temperature sensor
- (S) Sight glass
- (T) Thermal expansion valve, vapour injection
- (U) Filter dryer
- (V) High pressure sensor
- (W) Schrader valve, low pressure side
- (X) Hot gas temperature sensor
- (Y) Heat exchanger, vapour injection

5655006



Draining the heat pump on the primary/secondary side

1. Shut off the connection to the heating network.
2. Drain the heat pump at the primary/secondary side drain valve: See page 65.

Checking the sensors

For sensor connections to the controller and sensor PCB: See page 33.

For the position of the sensors in the heat pump: See diagram on page 65.

Sensor	Test element
<ul style="list-style-type: none"> ▪ Outside temperature sensor (F0) ▪ Buffer temperature sensor (F4) ▪ Cylinder temperature sensor, top (F6) ▪ Cylinder temperature sensor, bottom (F7) ▪ Flow temperature sensor, heating circuit with mixer M2/HC2 (F12) ▪ System flow temperature sensor (F13) ▪ Cooling circuit flow temperature sensor (direct heating circuit A1/HC1 or separate cooling circuit SKK) (F14) ▪ Room temperature sensor, cooling circuit (F16) ▪ Boiler water temperature sensor, external heat generator (F20) ▪ Room temperature sensors for heating circuits 	<p>NTC 10 kΩ</p>
<ul style="list-style-type: none"> ▪ Flow temperature sensor, primary circuit (F2) ▪ Return temperature sensor, primary circuit (F3) ▪ Flow temperature sensor, secondary circuit, in a 2-stage heat pump for heat pump stage 1 (F8) ▪ Return temperature sensor, secondary circuit, in a 2-stage heat pump for heat pump stage 1 (F9) ▪ Secondary circuit return temperature sensor for heat pump stage 2 (F18) ▪ Secondary circuit flow temperature sensor for heat pump stage 2 (F27) ▪ Sensors in the refrigerant circuit 	<p>Pt500A (PTC)</p>

Checking the sensors (cont.)

Viessmann NTC 10 k Ω (blue marking)

$\vartheta / ^\circ\text{C}$	R / k Ω	$\vartheta / ^\circ\text{C}$	R / k Ω	$\vartheta / ^\circ\text{C}$	R / k Ω	$\vartheta / ^\circ\text{C}$	R / k Ω	$\vartheta / ^\circ\text{C}$	R / k Ω	$\vartheta / ^\circ\text{C}$	R / k Ω
-40	336.500	-8	49.647	24	10.449	56	2.878	88	0.976	120	0.389
-39	314.870	-7	47.055	25	10.000	57	2.774	89	0.946	121	0.379
-38	294.780	-6	44.614	26	9.572	58	2.675	90	0.918	122	0.369
-37	276.100	-5	42.315	27	9.165	59	2.579	91	0.890	123	0.360
-36	258.740	-4	40.149	28	8.777	60	2.488	92	0.863	124	0.351
-35	242.590	-3	38.107	29	8.408	61	2.400	93	0.838	125	0.342
-34	227.550	-2	36.181	30	8.057	62	2.316	94	0.813	126	0.333
-33	213.550	-1	34.364	31	7.722	63	2.235	95	0.789	127	0.325
-32	200.510	0	32.650	32	7.402	64	2.158	96	0.765	128	0.317
-31	188.340	1	31.027	33	7.098	65	2.083	97	0.743	129	0.309
-30	177.000	2	29.495	34	6.808	66	2.011	98	0.721	130	0.301
-29	166.350	3	28.048	35	6.531	67	1.943	99	0.700	131	0.293
-28	156.410	4	26.680	36	6.267	68	1.877	100	0.680	132	0.286
-27	147.140	5	25.388	37	6.016	69	1.813	101	0.661	133	0.279
-26	138.470	6	24.165	38	5.775	70	1.752	102	0.642	134	0.272
-25	130.370	7	23.009	39	5.546	71	1.694	103	0.623	135	0.265
-24	122.800	8	21.916	40	5.327	72	1.637	104	0.606	136	0.259
-23	115.720	9	20.880	41	5.117	73	1.583	105	0.589	137	0.253
-22	109.090	10	19.900	42	4.917	74	1.531	106	0.572	138	0.247
-21	102.880	11	18.969	43	4.726	75	1.481	107	0.556	139	0.241
-20	97.070	12	18.087	44	4.543	76	1.433	108	0.541	140	0.235
-19	91.600	13	17.251	45	4.369	77	1.387	109	0.526	141	0.229
-18	86.474	14	16.459	46	4.202	78	1.342	110	0.511	142	0.224
-17	81.668	15	15.708	47	4.042	79	1.299	111	0.497	143	0.219
-16	77.160	16	14.995	48	3.889	80	1.258	112	0.484	144	0.213
-15	72.929	17	14.319	49	3.743	81	1.218	113	0.471	145	0.208
-14	68.958	18	13.678	50	3.603	82	1.180	114	0.458	146	0.204
-13	65.227	19	13.069	51	3.469	83	1.143	115	0.445	147	0.199
-12	61.722	20	12.490	52	3.340	84	1.107	116	0.434	148	0.194
-11	58.428	21	11.940	53	3.217	85	1.072	117	0.422	149	0.190
-10	55.330	22	11.418	54	3.099	86	1.039	118	0.411	150	0.185
-9	52.402	23	10.921	55	2.986	87	1.007	119	0.400		

Checking the sensors (cont.)

Viessmann Pt500A (green marking)

$\vartheta / ^\circ\text{C}$	R / Ω	$\vartheta / ^\circ\text{C}$	R / Ω	$\vartheta / ^\circ\text{C}$	R / Ω	$\vartheta / ^\circ\text{C}$	R / Ω	$\vartheta / ^\circ\text{C}$	R / Ω	$\vartheta / ^\circ\text{C}$	R / Ω
-30	441.1	1	502.0	32	562.3	63	623.9	94	681.2	125	739.8
-29	443.1	2	503.9	33	564.2	64	622.0	95	683.1	126	741.7
-28	445.1	3	505.9	34	566.1	65	625.8	96	685.0	127	743.5
-27	447.0	4	507.8	35	568.1	66	627.7	97	686.9	128	745.4
-26	449.0	5	509.8	36	570.0	67	629.7	98	688.8	129	747.3
-25	451.0	6	511.7	37	571.9	68	631.6	99	690.7	130	749.2
-24	453.0	7	513.7	38	573.9	69	633.5	100	692.6	131	751.1
-23	454.9	8	515.6	39	575.8	70	635.4	101	694.4	132	752.9
-22	456.9	9	517.6	40	577.7	71	637.3	102	696.3	133	754.8
-21	458.9	10	519.5	41	579.7	72	639.2	103	698.2	134	756.7
-20	460.8	11	521.5	42	581.6	73	641.1	104	700.1	135	758.6
-19	462.8	12	523.4	43	583.5	74	643.1	105	702.0	136	760.4
-18	464.8	13	525.4	44	585.4	75	645.0	106	703.9	137	762.3
-17	466.7	14	527.3	45	587.4	76	646.9	107	705.8	138	764.2
-16	468.7	15	529.3	46	589.3	77	648.8	108	707.7	139	766.1
-15	470.6	16	531.2	47	591.2	78	650.7	109	709.6	140	767.9
-14	472.6	17	533.2	48	593.2	79	652.6	110	711.5	141	769.8
-13	474.6	18	535.1	49	595.1	80	654.5	111	713.4	142	771.7
-12	476.5	19	537.0	50	597.0	81	656.4	112	715.3	143	773.6
-11	478.5	20	539.0	51	598.9	82	658.3	113	717.2	144	775.4
-10	480.5	21	540.9	52	600.9	83	660.2	114	719.0	145	777.3
-9	482.4	22	542.9	53	602.8	84	662.1	115	720.9	146	779.2
-8	484.4	23	544.8	54	604.7	85	664.0	116	722.8	147	781.0
-7	486.3	24	546.8	55	606.6	86	665.9	117	724.7	148	782.9
-6	488.3	25	548.7	56	608.6	87	667.9	118	726.6	149	784.8
-5	490.2	26	550.6	57	610.5	88	669.8	119	728.5	150	786.7
-4	492.2	27	552.6	58	612.4	89	671.7	120	730.4	151	788.5
-3	494.2	28	554.5	59	614.0	90	673.6	121	732.2	152	790.4
-2	496.1	29	556.5	60	616.2	91	675.5	122	734.1	153	792.3
-1	498.1	30	558.4	61	618.2	92	677.4	123	736.0	154	794.1
0	500.0	31	560.3	62	620.1	93	679.3	124	737.9	155	796.0

Checking MCBs/fuses

Fuse location: See page 23.

- Fuse F1 is located on the cross connect PCB.
- Fuse F3 is located on the main PCB.

Fuses F1 and F3:

- 6.3 A (slow), 250 V~
- Max. power loss ≤ 2.5 W

1. Switch OFF the power supply.
2. Opening the wiring chamber.

3. Check fuses. Replace if necessary.



Danger

Incorrect or improperly fitted fuses can lead to an increased risk of fire.

- Insert fuses without using any force. Position fuses correctly.
- Only use structurally identical types with the same response characteristics.

Checking MCBs/fuses (cont.)



Danger

Removing the fuse does **not switch the power circuit to zero volt**. Contact with 'live' components can lead to serious injury from electric current.

Before working on the equipment, always ensure that **the power circuit is also at zero volt**.

The appliance is too noisy

Possible causes:

- Transport bracket not removed or not secured to the base support: See page 15.
- Hose outlets in diaphragm grommets are leaking: See page 48.
- Hoses are in contact with other components.
- Casing door not closed tight: See following diagram.
- Plinth trims not fitted: See page 47.
- Excessive clearance between the plinth trim and floor

Condensation and moisture in the heat pump module

Possible causes:

- Hose outlets in diaphragm grommets are leaking: See page 48.
- Casing door not closed tight: See diagram in following chapter "Removing the heat pump module".
- Outer panels not sealed so as to be diffusion-proof: See page 45.

Removing the heat pump module

- ! Please note**
 Impacts, compression and tensile loads can cause damage to the outside panels of the appliance.
Never apply loads/weight to the top, front or side panels of the appliance.

4. Drain the primary and secondary sides: For drain valves, see page 65.

- ! Please note**
 Steep tilting of the compressor in the heat pump can result in appliance damage.
 Max. tilting angle: 45° for a very short time

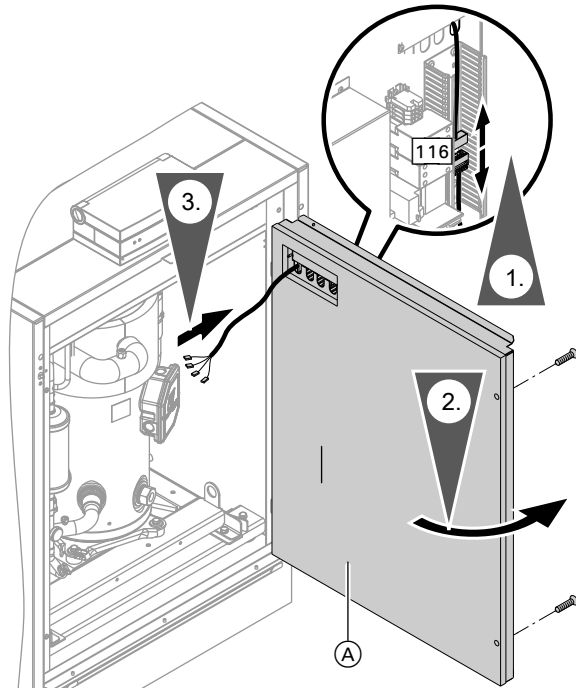

Fig. 42

- Ⓐ Casing door

Removing the heat pump module (cont.)

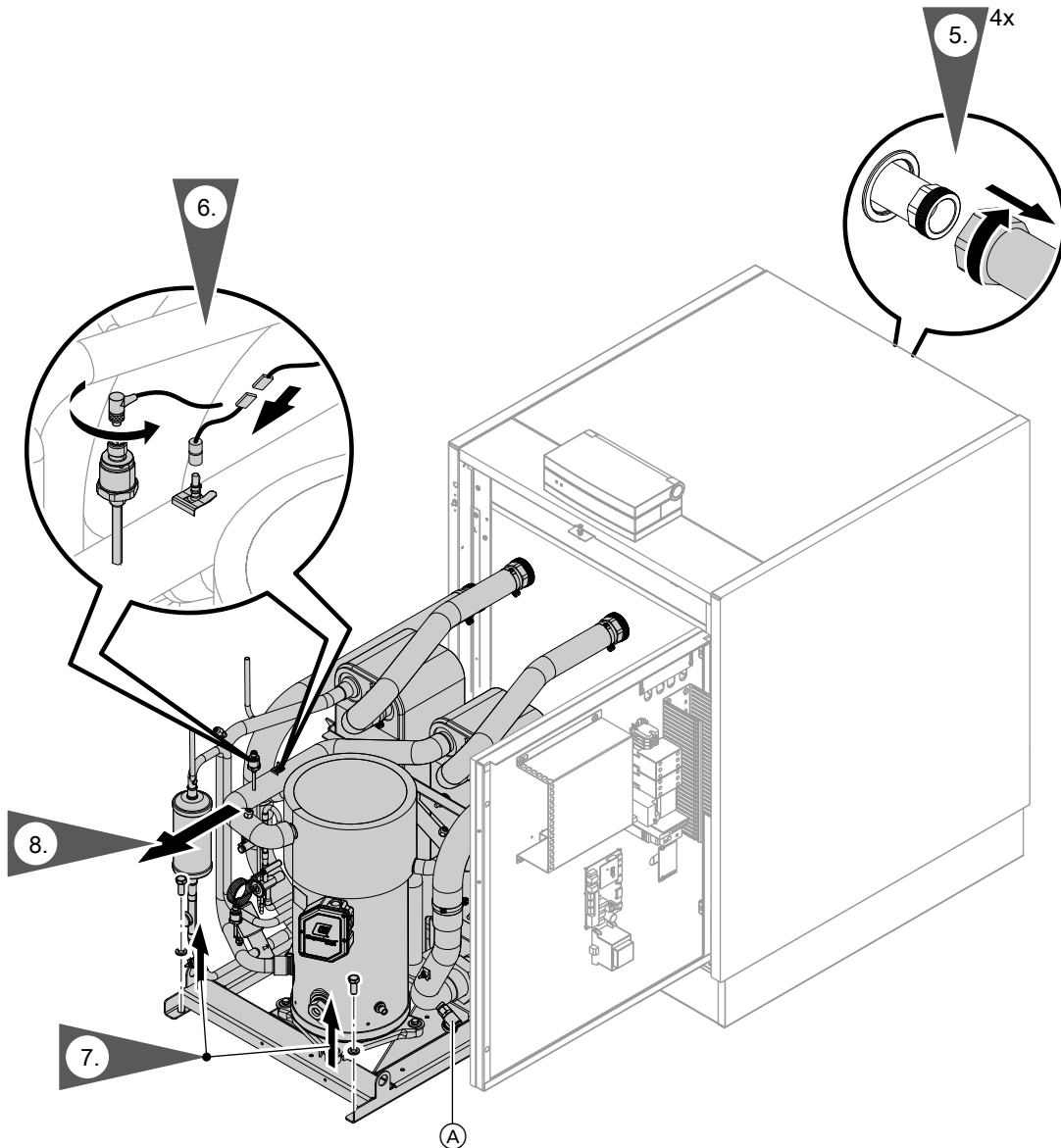

Fig. 43

6. Mark the plug-in and threaded connections that belong together.
Disconnect **all** electrical connections.

8. **Note**
To stabilise the heat pump module on its support, it may be necessary to attach the transport bracket: See page 15.

Installing the heat pump module

Install in reverse order to removal.

- ! **Please note**
 - If the casing is not securely sealed, this can lead to damage from condensate, vibrations and excessive noise.
 - Seal the casing door so it is soundproof and diffusion-proof.
 - Ensure the diaphragm grommets at the hose outlets are seated correctly. Seal hose outlets with sealing tape if necessary: See page 48.

- ! **Please note**
 - Leaking hydraulic connections lead to appliance damage.
 - Check the internal and on-site hydraulic connections for leaks.
 - In the event of leaks, switch OFF the appliance immediately. Drain off liquid via the drain valve. Check the seating of seal rings. **Always** replace displaced seal rings.

Hydraulic parameter report

Settings and test values	Set value	Commissioning	Maintenance/ service
Frost protection (brine medium) °C	-19		
Testing the external heating circuit pumps			
Circulation pump type			
Circulation pump stage			
Overflow valve setting			
Primary circuit commissioning			
Primary circuit flow temperature ("Diagnosis" → "System overview") °C			
Primary circuit return temperature ("Diagnosis" → "System overview") °C			
Temperature differential (primary circuit flow/return) ΔT :			
<ul style="list-style-type: none"> ▪ At secondary circuit flow temperature = 35 °C and primary circuit flow temperature = 10 °C 	K	4 to 6	
<ul style="list-style-type: none"> ▪ At secondary circuit flow temperature = 35 °C and primary circuit flow temperature = 0 °C 	K	3 to 5	
Checking mixer, heat pump and cylinder heating			
Checked under the following conditions:			
Room temperature °C			
Outside temperature °C			
Temperature "Cylinder temp. top" constant?	Yes (± 1 K)		
Secondary circuit flow temperature °C	Rising	From	To
Temperature differential ΔT "Flow temp. secondary" / "Return temp. sec."	K	6 to 8	

Control parameter report



Parameter description

"Vitotronic 200" service instructions

System definition

Parameter	Code	Delivered condition	Commissioning	Maintenance/ Service
"System scheme" (see chapter "Overview of possible system schemes")	7000	2		
Interval for long term average outside temperature	7002	180 min		
Temperature differential for calculating the heating limit	7003	40 (± 4 K)		
Temperature differential for calculating the cooling limit	7004	40 (± 4 K)		
Swimming pool	7008	0		
"Cascade control"	700A	0		
"Use of heat pump in cascade"	700C	2		

Control parameter report (cont.)

Parameter	Code	Delivered condition	Commissioning	Maintenance/Service
Runtime balance cascade	700D	0		
Output control strategy, cascade	700F	0		
External extension	7010	0		
System components for external change-over	7011	0		
Operating status for external changeover	7012	2		
Duration of external changeover	7013	8 h		
Effect of external demand on heat pump/heating circuits	7014	4		
Effect of ext. blocking on heat pump/heating circuits	7015	4		
Vitocom 100 (type GSM/GSM2 only)	7017	0		
Temperature range input 0..10 V	7018	1000		
Priority external demand	7019	0		
Effect of external blocking on pumps/compressor	701A	0		
Common flow temperature sensor system	701B	0		
Operating status after message A9, C9	701C	0		
Effect of OM changeover to ventilation	701F	3		
Number of lag heat pumps	7029	0		
"Select primary source"	7030	0		
Start hysteresis solar air absorber	7031	20 (\pm 2 K)		
Minimum temp. for solar absorber primary source	7033	-500 (\pm -50 °C)		
Min. runtime to suppress summer mode	7035	60 min		
Last calendar week for summer mode	7036	35		
Absorber circuit monitoring	7037	0		
Temperature sensor for dual mode operation	7038	0		
Holiday program effect	7050	384		

Compressor/Compressor 1

Parameter	Code	Delivered condition	Commissioning	Maintenance/service
Enable compressor	5000	1		
Max. flow temperature secondary circuit	5001	680 (\pm 68 °C)		
Enable use of compressor stage	5012	15		
Output compressor stage	5030	Rated heating output according to type plate		
Primary source output	5043	0		

Control parameter report (cont.)**Compressor 2**

Parameter	Code	Delivered condition	Commissioning	Maintenance/service
Enable compressor	5100	0		
Enable use of compressor stage	5112	14		
Primary source output	5143	0		
Output compressor stage	5130	Rated heating output according to type plate		

External heat generator

Parameter	Code	Delivered condition	Commissioning	Maintenance/service
"Enable external heat source"	7B00	0		
"Priority ext. heat source/instant. heating water heater"	7B01	1		
"Dual mode temperature external heat source"	7B02	100 (\pm 10 °C)		
"Start threshold external heat source"	7B03	300 (\pm 30 min)		
"Start delay external heat source"	7B04	30 min		
"Min. flow temperature mixer external heat source ON"	7B05	0		
"Min. runtime external heat source"	7B06	20 min		
"Run-on time external heat source"	7B07	10 min		
"Max. excess flow temp external heat source"	7B0B	0		
"Enable external heat gen. for central heating"	7B0C	1		
"Enable external heat source for DHW heating"	7B0D	0		
"Dual mode heat pump operation"	7B0E	1		
"Shutdown limit, heat pump dual mode"	7B0F	-500 (\pm -50 °C)		
"Enable min. temp. maintenance for ext. HS"	7B10	0		
"Enable boiler water temperature sensor"	7B11	1		

Control parameter report (cont.)**DHW**

Parameter	Code	Delivered condition	Commissioning	Maintenance/service
Set DHW temperature	6000	500 (\pm 50 °C)		
Min. DHW temperature	6005	100 (\pm 10 °C)		
Max. DHW temperature	6006	600 (\pm 60 °C)		
Hysteresis DHW temperature heat pump	6007	50 (\pm 5 K)		
Hysteresis DHW temperature booster heater	6008	100 (\pm 10 K)		
Start optimisation for DHW heating	6009	0		
Stop optimisation for DHW heating	600A	0		
Set DHW temperature 2	600C	600 (\pm 60 °C)		
Temperature rise per hour for DHW heating	600D	30 K/h		
Temperature sensor at bottom of DHW cylinder	600E	0		
Max. runtime DHW heating in heating mode	6011	240 min		
Max. interruption of DHW heating for central heating	6012	90 min		
Enable booster heaters for DHW heating	6014	0		
Enable electric heaters for DHW heating	6015	0		
Priority DHW heating with combi cylinder	6016	0		
Start attempts for DHW after high pressure shutdown	6017	1		
Shutdown hysteresis inst. heating water heater	601E	0 (\pm 0 K)		
Cylinder primary pump enable	601F	0		
Operating mode cylinder primary pump	6020	0		
Enable elec. heating/ext. HS for reheating only	6040	0		

Solar

Parameter	Code	Delivered condition	Commissioning	Maintenance/Service
"Type solar control unit"	7A00	0		
Parameters for solar control module, type SM1	C0xx	These parameters will only be displayed if the solar control module, type SM1, is connected to the heat pump and "Type solar control unit" is set to "3" . For a description of the parameters, see installation and service instructions for "solar control module, type SM1".		

Control parameter report (cont.)**Electric booster heater**

Parameter	Code	Delivered condition	Commissioning	Maintenance/Service
"Enable instantaneous heating water heater"	7900	0		
"Enable electric heaters for DHW heating"	7901	0		
"Enable instant. heating water heater for central heating"	7902	1		
Start delay instantaneous heating water heater	7905	30 min		
"Max. output instantaneous heating water heater"	7907	3		
"Output for instant. heating water heater at power-OFF"	790 A	0		
"Dual mode temp instant. heating water heater"	790 B	500 (\pm 50 °C)		

Internal hydraulics

Parameter	Code	Delivered condition	Commissioning	Maintenance/service
Heat pump for drying a building	7300	0		
Time program for screed drying	7303	0		
Set flow temperature for external demand	730C	500 (\pm 50 °C)		
Enable 3-way diverter valve, heating/DHW	730D	0		
Start threshold	730E	300 K·min		
Cycle rate heating circuit pumps	7319	0		
Operating mode, secondary pump	7340	0		
Secondary circuit pump type	735A	0		
Starting time, high efficiency circulation pump	7365	5		
Operating mode, secondary pump 2	73C0	0		

Primary source

Parameter	Code	Delivered condition	Commissioning	Maintenance/service
Primary source mode	7400	0		
Primary source ctrl strategy	7401	0		
Primary source start performance	7414	100 %		
Primary circuit pump type	745A	Do not adjust.		
Min. primary circuit inlet temperature in operation	7470	Do not adjust.		
Response delay, probe protection	7471	Do not adjust.		

Control parameter report (cont.)**Heating water buffer cylinder**

Parameters	Code	Delivered condition	Commissioning	Maintenance/service
"Enable buffer cylinder/low loss header"	7200	0		
"Temp in operating status fixed value for buffer cyl"	7202	500 (\pm 50 °C)		
"Hysteresis temperature heating buffer cylinder"	7203	50 (\pm 5 K)		
"Max. temperature buffer cylinder"	7204	600 (\pm 60 °C)		
Stop optimisation heating buffer cylinder	7205	0		
"Temp. limit op. status fixed value for buffer cylinder"	7208	500 (\pm 50 °C)		
Stop hysteresis, heating water buffer cylinder	7209	0 (\pm 0 K)		
Operating mode, fixed value only for heat demand	720A	0		

Heating circuit 1

Parameter	Code	Delivered condition	Commissioning	Maintenance/Service
"Standard room temperature"	2000	200 (\pm 20 °C)		
"Reduced room temperature"	2001	160 (\pm 16 °C)		
"Remote control"	2003	0		
Room temperature control	2005	0		
"Heating curve level"	2006	0 (\pm 0 K)		
"Heating curve slope"	2007	6 (\pm 0.6)		
"Influence room temperature hook-up"	200 A	10		
"Room temperature hook-up"	200 B	0		
"Max. flow temperature heating circuit"	200E	400 (\pm 40 °C)		
"Room temperature in party mode"	2022	200 (\pm 20 °C)		

Heating circuit 2

Parameter	Code	Delivered condition	Commissioning	Maintenance/Service
"Standard room temperature"	3000	200 (\pm 20 °C)		
"Reduced room temperature"	3001	160 (\pm 16 °C)		
"Remote control"	3003	0		
Room temperature control	3005	0		
"Heating curve level"	3006	0 (\pm 0 K)		
"Heating curve slope"	3007	6 (\pm 0.6)		
"Influence room temperature hook-up"	300 A	10		
"Room temperature hook-up"	300 B	0		
"Max. flow temperature heating circuit"	300E	400 (\pm 40 °C)		
Runtime mixer heating circ	3015	Do not adjust.		
"Room temperature in party mode"	3022	200 (\pm 20 °C)		

Control parameter report (cont.)**Heating circuit 3**

Parameter	Code	Delivered condition	Commissioning	Maintenance/Service
"Standard room temperature"	4000	200 (\pm 20 °C)		
"Reduced room temperature"	4001	160 (\pm 16 °C)		
"Remote control"	4003	0		
Room temperature control	4005	0		
"Heating curve level"	4006	0 (\pm 0 K)		
"Heating curve slope"	4007	6 (\pm 0.6)		
"Influence room temperature hook-up"	400 A	10		
"Room temperature hook-up"	400 B	0		
"Max. flow temperature heating circuit"	400E	400 (\pm 40 °C)		
Runtime mixer heating circ	4015	Do not adjust.		
"Room temperature in party mode"	4022	200 (\pm 20 °C)		

Cooling

Parameter	Code	Delivered condition	Commissioning	Maintenance/Service
"Cooling function"	7100	0		
"Cooling circuit"	7101	1		
"Set room temperature separate cooling circuit"	7102	200 (\pm 20 °C)		
"Min. flow temperature cooling"	7103	200 (\pm 20 °C)		
"Influence room temperature hook-up cooling circuit"	7104	0		
Room temperature control cooling circuit	7105	1		
"Ranking room temp sensor separate cooling circuit"	7106	0		
Hysteresis room temp cooling circuit	7107	10 (\pm 1 K)		
Enable flow temperature sensor cooling circuit	7109	1		
"Cooling curve level"	7110	0 (\pm 0 K)		
"Cooling curve slope"	7111	12 (\pm 1.2)		
"Remote control cooling circ"	7116	0		
Dew point monitor	7117	1		
"Enable active cooling"	71FE	0		

Ventilation: Vitovent 200-C and Vitovent 300-F

Parameter	Code	Delivered condition	Commissioning	Maintenance/service
Vitovent enable	7D00	0		
Enable preheater bank electric	7D01	0		
Enable reheater bank hydraulic	7D02	0		
Enable humidity sensor	7D05	0		
Enable CO2 sensor	7D06	0		
Set room temperature	7D08	200 (\pm 20 °C)		
Flow rate reduced ventilation	7D0A	<ul style="list-style-type: none"> ▪ Vitovent 200-C: 75 m³/h ▪ Vitovent 300-F: 120 m³/h 		

Control parameter report (cont.)

Parameter	Code	Delivered condition	Commissioning	Maintenance/service
Flow rate nominal ventilation	7D0B	<ul style="list-style-type: none"> ▪ Vitovent 200-C: 115 m³/h ▪ Vitovent 300-F: 170 m³/h 		
Flow rate intensive ventilation	7D0C	<ul style="list-style-type: none"> ▪ Vitovent 200-C: 155 m³/h ▪ Vitovent 300-F: 215 m³/h 		
Min. supply air temperature for bypass	7D0F	160 (± 16 °C)		
CO2 value for raising the flow rate	7D18	800 ppm		
Humidity value for raising the flow rate	7D19	65 %		
Interval time frost protection ventilation	7D1A	15 min		
Intensive ventilation duration	7D1B	120 min		
Actual source room temperature	7D1D	1		
Heating circuit for blocking bypass damper	7D21	7		
Control voltage matching	7D27	0 (± 0 V)		
Fan for control voltage matching	7D28	0		
Strategy, passive frost protection	7D2C	0		
Type of heat exchanger	7D2E	0		
Installation position	7D2F	0		
Function, external 230 V input, ventilation	7D3A	0		
Duration, bathroom vent.	7D3B	30 min		
Starting block, ventilation periods part 1	7D5E	0		
Starting block, ventilation periods part 2	7D5F	0		
Control voltage matching, supply air fan	7D71	0 V		
Control voltage matching, exhaust air fan	7D72	0 V		
Sensor matching, outdoor air temperature	7D75	0 K		
Sensor matching, outdoor air temp after pre-heating coil	7D76	0 K		
Sensor matching, supply air temperature	7D77	0 K		
Sensor matching, extract air temperature	7D79	0 K		

Ventilation: Vitovent 200-W, Vitovent 300-C and Vitovent 300-W

Parameter	Code	Delivered condition	Commissioning	Maintenance/service
Vitovent enable	7D00	0		
Heating circuit for blocking bypass damper	7D21	7		
Preheater coil	C101	1		
Reheater coil	C102	0		
Humidity sensor	C105	0		
Set CO2 value	C106	0		
Set room temperature	C108	220 (± 22 °C)		
Background ventilation	C109	<ul style="list-style-type: none"> ▪ Vitovent 200-W: 15 % ▪ Vitovent 300-C: 30 m³/h ▪ Vitovent 300-W: 50 m³/h 		

Control parameter report (cont.)

Parameter	Code	Delivered condition	Commissioning	Maintenance/service
Reduced ventilation	C10A	<ul style="list-style-type: none"> ▪ Vitovent 200-W: 25 % ▪ Vitovent 300-C: 75 m³/h ▪ Vitovent 300-W: 100 m³/h 		
Standard ventilation	C10B	<ul style="list-style-type: none"> ▪ Vitovent 200-W: 50 % ▪ Vitovent 300-C: 100 m³/h ▪ Vitovent 300-W: 150 m³/h 		
Intensive ventilation	C10C	<ul style="list-style-type: none"> ▪ Vitovent 200-W: 75 % ▪ Vitovent 300-C: 125 m³/h ▪ Vitovent 300-W: 225 m³/h 		
Background ventilation, second fan duct	C189	15 %		
Reduced ventilation, second fan duct	C18A	25 %		
Standard ventilation, second fan duct	C18B	50 %		
Intensive ventilation, second fan duct	C18C	75 %		
Bypass mode	C1A0	0		
Central heating and heat recovery	C1A1	0		
Imbalance permitted	C1A2	1		
Specified imbalance	C1A3	0		
Set reheater coil temperature	C1A4	210 (\pm 21 °C)		
Humidity sensor sensitivity	C1A6	0		
Min. temperature, geothermal heat exchanger	C1AA	50 (\pm 5 °C)		
Max. temperature, geothermal heat exchanger	C1AB	250 (\pm 25 °C)		
Function, input 1	C1B0	0		
Min. voltage, input 1	C1B1	0 (10 \pm 1 V)		
Min. voltage, input 2	C1C1	0 (10 \pm 1 V)		
Flow rate correction	C1C7	100		

Note

The factory settings of parameters C101 to C1C7 depend on the ventilation unit and may differ from the values specified here. The factory setting is displayed in the service menu for each parameter with "**Del con ...**": "▼" See "Vitotronic 200 service instructions".

Control parameter report (cont.)**Photovoltaics**

Parameter	Code	Factory setting	Commissioning	Maintenance/service
"Enable own energy consumption PV"	7E00	0		
"Prop. of external current"	7E02	10 (\pm 10 %)		
"Threshold for electrical power"	7E04	0 (\pm 0 W)		
"Enable own energy consumptn for set DHW temperature 2"	7E10	0		
"Enable own energy consumption for DHW heating"	7E11	0		
"Enable own energy consumptn for heating water buffer cyl."	7E12	0		
"Enable own energy consumption for heating"	7E13	0		
"Enable own energy consumption for cooling"	7E15	0		
"Raise set DHW cylinder temperature PV"	7E21	0 (\pm 0 K)		
"Raise set heating water buffer cylinder temp PV"	7E22	0 (\pm 0 K)		
"Raise set room temperature PV"	7E23	0 (\pm 0 K)		
"Reduce set room temperature PV"	7E25	0 (\pm 0 K)		

Smart Grid

Parameter	Code	Delivered condition	Commissioning	Maintenance/Service
"Enable Smart Grid"	7E80	0		
"Smart Grid Enable elec heat"	7E82	0		
"Smart Grid set value increase for DHW heating"	7E91	0 (\pm 0 K)		
"Smart Grid set value increase for htg wtr buff"	7E92	0 (\pm 0 K)		
"Smart Grid set value increase for centr htg"	7E93	0 (\pm 0 K)		
"Smart Grid set value decrease for room t cool"	7E95	0 (\pm 0 K)		

Time

Parameter	Code	Delivered condition	Commissioning	Maintenance/Service
"Automatic changeover summertime - wintertime"	7C00	1		
"Start summertime - month"	7C01	3		
"Start summertime - week"	7C02	5		
"Start summertime - day"	7C03	7		
"Start wintertime - month"	7C04	10		
"Start wintertime - week"	7C05	5		
"Start wintertime - day"	7C06	7		

Control parameter report (cont.)**Communication**

Parameter	Code	Delivered condition	Commissioning	Maintenance/Service
"Number of heat pump in cascade"	7707	1		
"Enable LON communication module"	7710	0		
"LON subscriber number"	7777	1		
"LON fault manager"	7779	0		
"LON system number"	7798	1		
"Interval for data transfer via LON"	779C	20 min		
"Source outside temperature"	77FC	0		
"Send outside temperature"	77FD	0		
"Source time"	77FE	0		
"Send time"	77FF	0		

Control

Parameter	Code	Delivered condition	Commissioning	Maintenance/service
"Lock out controls"	8800	0		
"Level enable, time program quieter operation"	8801	0		
"User level for display, energy stmt"	8811	1		

Specification

Specification for brine/water heat pumps

Type BW/BWS		351.B20	351.B27	351.B33	351.B42
Performance data to EN 14511 (B0/W35, 5 K spread)					
Rated heating output	kW	20.5	28.7	32.7	42.3
Cooling capacity	kW	16.4	23.0	26.3	33.6
Power consumption	kW	4.30	5.90	6.50	8.70
Coefficient of performance (COP)		4.80	4.90	5.00	4.80
Brine (primary circuit)					
Capacity	l	9	11	14	14
Nominal flow rate (3 K spread)	l/h	5350	7200	8300	10500
Pressure drop at nominal flow rate	mbar	100	50	84	124
	kPa	10.0	5.0	8.4	12.4
Minimum flow rate (4 K spread)	l/h	4000	5400	6200	7900
Pressure drop at minimum flow rate	mbar	63	30	52	78
	kPa	6.3	3.0	5.2	7.8
Max. flow temperature (brine inlet)	°C	25	25	25	25
Min. flow temperature (brine inlet)	°C	-10	-10	-10	-10
Heating water (secondary circuit)					
Capacity	l	8	9	13	13
Nominal flow rate (5 K spread)	l/h	3500	4800	5650	7000
Pressure drop at nominal flow rate	mbar	42	40	65	99
	kPa	4.2	4.0	6.5	9.9
Minimum flow rate (12 K spread)	l/h	1500	2050	2400	3000
Pressure drop at minimum flow rate	mbar	7	10	16	23
	kPa	0.7	1.0	1.6	2.3
Max. flow temperature (6 K spread)	°C	65	68	68	68
Electrical values, heat pump					
Rated voltage, compressor	V	3/PE 400 V/50 Hz			
Rated current, compressor	A	13.2	21	26	33
Cos φ		0.8	0.8	0.8	0.8
Starting current, compressor (with starting current limiter)	A	36	39	43	59
Starting current, compressor with stalled armature	A	101	118	140	174
Compressor MCB/fuse protection	A	1 x C25A 3-pole	1 x C32A 3-pole	1 x C32A 3-pole	1 x C40A 3-pole
Protection class		I	I	I	I
Electrical values, heat pump control unit					
Rated voltage, heat pump control unit/PCB	V	1/N/PE 230 V/50 Hz			
Fuse rating, heat pump control unit/PCB		1 x B16A			
Fuse, heat pump control unit/PCB	A	6.3 A (slow)/250 V			
IP rating		IP 20	IP 20	IP 20	IP 20
Power consumption					
Max. power consumption, heat pump control unit/PCB, heat pump stage 1 (type BW 351.B)	W	25	25	25	25
Max. power consumption, PCB, heat pump stage 2 (type BWS 351.B)		20	20	20	20
Power consumption, heat pump control unit/PCB, stages 1 and 2	W	45	45	45	45

Specification for brine/water heat pumps (cont.)

Type BW/BWS		351.B20	351.B27	351.B33	351.B42
Refrigerant circuit					
Refrigerant		R410A	R410A	R410A	R410A
▪ Refrigerant charge	kg	5.3	7.0	8.6	8.7
▪ Global warming potential (GWP) ²		1924	1924	1924	1924
▪ CO ₂ equivalent	t	10.2	13.5	16.5	16.7
Permiss. operating pressure, high pressure side	bar	45	45	45	45
	MPa	4.5	4.5	4.5	4.5
Permiss. operating pressure, low pressure side	bar	28	28	28	28
	MPa	2.8	2.8	2.8	2.8
Compressor	Type	Hermetically sealed scroll compressor			
Oil in compressor	Type	Emkarate RL32 3MAF			
Quantity of oil in compressor	l	1.9	3.4	3.4	3.4
Permiss. operating pressure					
Primary circuit	bar	3	3	3	3
	MPa	0.3	0.3	0.3	0.3
Secondary circuit	bar	3	3	3	3
	MPa	0.3	0.3	0.3	0.3
Dimensions					
Total length	mm	1085	1085	1085	1085
Total width	mm	780	780	780	780
Total height without programming unit	mm	1074	1074	1074	1074
Total height (programming unit pivoted up, type BW 351.B only)	mm	1267	1267	1267	1267
Weight					
Heat pump stage 1 (type BW 351.B)	kg	270	285	310	315
Heat pump stage 2 (type BWS 351.B)	kg	265	280	305	310
Connections (male thread)					
Primary circuit flow/return	G	2	2	2	2
Secondary circuit flow/return	G	2	2	2	2
Sound power (measured with reference to EN 12102/EN ISO 9614-2)					
Weighted total sound power level for B0±3 K/W35±5 K					
▪ At rated heating output	dB(A)	50	52	50	50
Energy efficiency class to EU Regulation no. 813/2013					
Heating, average climatic conditions					
▪ Low temperature applications (W35)		A ⁺⁺	A ⁺⁺	A ⁺⁺	A ⁺⁺
▪ Medium temperature applications (W55)		A ⁺⁺	A ⁺⁺	A ⁺⁺	A ⁺⁺

5655006 ² Based on the Fifth Assessment Report of the Intergovernmental Panel on Climate Change (IPCC).

Specification

Specification for brine/water heat pumps (cont.)

Type BW/BWS		351.B20	351.B27	351.B33	351.B42
Performance data as per EU Regulation no. 813/2013 (average climatic conditions)					
Low temperature applications (W35)					
▪ Energy efficiency η_S	%	196	203	213	203
▪ Rated heating output P_{rated}	kW	23	32	37	48
▪ Seasonal coefficient of performance (SCOP)		5.10	5.28	5.53	5.28
Medium temperature applications (W55)					
▪ Energy efficiency η_S	%	152	153	156	153
▪ Rated heating output P_{rated}	kW	23	34	38	49
▪ Seasonal coefficient of performance (SCOP)		4.00	4.03	4.10	4.03

Specification for water/water heat pumps

Type BW/BWS in conjunction with "conversion kit for water/water heat pump"		351.B20	351.B27	351.B33	351.B42
Performance data to EN 14511 (W10/W35, 5 K spread)					
Rated heating output	kW	25.4	34.7	42.2	52.3
Cooling capacity	kW	21.1	29.3	35.7	43.8
Power consumption	kW	4.50	5.70	6.80	9.00
Coefficient of performance (COP)		5.70	6.10	6.20	5.80
Brine (primary intermediate circuit)					
Capacity	l	9	11	14	14
Nominal flow rate (3 K spread)	l/h	6400	9500	10300	14000
Pressure drop at nominal flow rate	mbar	145	80	120	320
	kPa	14.5	8.0	12.0	32.0
Minimum flow rate (5 K spread)	l/h	4800	6500	7700	10500
Pressure drop at minimum flow rate	mbar	90	42	77	124
	kPa	9.0	4.2	7.7	12.4
Max. flow temperature (brine inlet)	°C	25	25	25	25
Min. flow temperature (brine inlet)	°C	7.5	7.5	7.5	7.5
Heating water (secondary circuit)					
Capacity	l	8	9	13	13
Nominal flow rate (5 K spread)	l/h	4300	5700	7300	9000
Pressure drop at nominal flow rate	mbar	68	53	105	154
	kPa	6.8	5.3	10.5	15.4
Minimum flow rate (12 K spread)	l/h	1800	2400	3050	3750
Pressure drop at minimum flow rate	mbar	11	13	23.0	33
	kPa	1.1	1.3	2.3	3.3
Max. flow temperature (6 K spread)	°C	65	68	68	68

Note

Further specifications: See "Specification for brine/water heat pumps".

Commissioning order

Fax the following request, together with the enclosed system scheme, to your local Viessmann sales office. A competent employee must be present when the system is commissioned.

System details:

Client _____

System location _____

Please tick these check points:

- Hydraulic scheme for heating system included
- Heating circuits fully installed and filled
- Electrical installation completed
- Hydraulic lines fully thermally insulated
- All windows and external doors sealed
- Components for cooling mode fully installed (optional)
- Components for ventilation fully installed (optional)
- Components for PV system fully installed (optional)

Preferred appointment:

1. Date _____
 Time _____
2. Date _____
 Time _____

The work that is requested to be carried out by Viessmann will be billed in accordance with the latest Viessmann pricelist.

Place / Date _____

Signature _____

Final decommissioning and disposal

Viessmann products can be recycled. Components and substances from the system are not part of ordinary household waste.

For decommissioning the system, isolate the system from the power supply and allow components to cool down where appropriate. All components must be disposed of correctly.

Declaration of conformity

We, Viessmann Werke GmbH & Co. KG, D-35107 Allendorf, declare as sole responsible body that the named product complies with the European directives and supplementary national requirements in terms of its design and operational characteristics.

Using the serial number, the full Declaration of Conformity can be found on the following website:
www.viessmann.co.uk/eu-conformity

The **product characteristics** determined as system values for the product **Vitocal 350-G** (see technical guide) can be utilised to assess the energy consumption of heating and ventilation systems to DIN V 4701-10 specified by the EnEV [Germany].

Keyword index

- A**
- Adjustable feet..... 14
 - AM1 extension..... 33
 - Ambient temperatures..... 12
 - Appliance MCBs/fuses..... 68
 - Appliance too noisy..... 69
 - Application..... 7
- B**
- Base support..... 15
 - Boiler water temperature sensor..... 33
 - Boiler water temperature sensor, external heat generator..... 66
 - Brine/water heat pump..... 8
 - Buffer temperature sensor..... 33, 66
- C**
- Cable length..... 18, 19, 37
 - Casing door..... 64, 69
 - Central fault message..... 28
 - Checking
 - MCBs/fuses..... 68
 - Sensors..... 66
 - Circulation pump for cylinder heating..... 34, 55
 - Circulation pump for DHW reheating..... 55
 - Circulation pumps..... 55
 - Coding card..... 33
 - Coding level 1..... 52
 - Coefficients
 - Temperature sensor, type NTC 10 kΩ..... 67
 - Temperature sensor, type Pt500A..... 68
 - Commissioning..... 49, 52, 87
 - Commissioning assistant..... 51, 52
 - Commissioning order..... 87
 - Compressor..... 65
 - Power cable..... 19
 - Condensation in heat pump module..... 69
 - Condenser..... 65
 - Conditions for siting..... 11
 - Connecting cables..... 64
 - Connection conditions..... 36
 - Connections
 - Electrical..... 18
 - Hydraulic..... 16
 - Overview..... 10
 - Primary circuit..... 17
 - Secondary circuit..... 17
 - Contact humidistat..... 33
 - Controller and sensor PCB..... 23, 33, 64
 - Control parameter reports..... 73
 - Cooling function..... 57
 - Cross connect PCB..... 23, 31, 64
 - Cylinder loading pump
 - Parameters..... 55
 - Cylinder temperature sensor..... 33, 66
- D**
- DHW circulation pump..... 55
 - Diaphragm grommets..... 17, 18, 48, 72
 - Checking..... 48
 - Dimensions..... 10
 - Draining, secondary side..... 66
 - Drain valve
 - Primary side..... 65
 - Secondary side..... 65
- E**
- EA1 extension..... 33
 - Economy tariff meter..... 38, 39, 40, 41
 - EEV PCB..... 64
 - Electrical connection..... 18, 20, 22
 - Electrical connections
 - Checking..... 51
 - Controller and sensor PCB..... 33
 - Cross connect PCB..... 31
 - Expansion PCB..... 27
 - Heat pump control unit..... 23
 - Overview..... 23, 64
 - Electric booster heater..... 58
 - Electronic expansion valve..... 8, 65
 - Energy meter..... 33
 - Evaporator..... 65
 - Expansion PCB..... 23, 27, 64
 - Expansion vessel..... 17, 50
 - Checking..... 51
 - Checking pre-charge pressure..... 51
 - Extended menu..... 54
 - External extension..... 56
 - External functions..... 56
 - External heat generator..... 58
- F**
- Feed..... 38, 39, 40, 41
 - Filling
 - Primary circuit..... 50
 - Secondary circuit..... 51
 - Fill water..... 51
 - Filter dryer..... 65
 - Floor load..... 12
 - Floor unevenness..... 14
 - Flow temperature sensor
 - Cooling circuit..... 33, 66
 - Heating circuit..... 66
 - Heating circuit with mixer..... 34
 - Heating circuit with mixer M2/HC2..... 33
 - Primary circuit..... 65, 66
 - Secondary circuit..... 33, 65, 66
 - System..... 33, 66
 - Frost stat..... 45
 - Function components..... 23
 - Function test..... 63
 - Fuse protection..... 37
 - Fuses..... 23

H		N	
Heating circuit pump.....	55	Noise.....	15, 45, 48, 69, 72
– Parameters.....	55	Noise level.....	69
Heat pump		Non-return valves, opening.....	51
– Checking for noise.....	63	O	
– Closing.....	45	ON/OFF switch.....	49, 52
– Positioning.....	14	On-site power consumption.....	42
– Siting.....	11	Operating noise.....	63
– Starting.....	51	Output extension.....	8
Heat pump cascade.....	62	Outside temperature sensor.....	33, 66
Heat pump control unit.....	18	Overview	
– Power cable.....	19	– Electrical connections.....	23
Heat pump module		– Internal components.....	65
– Installation.....	72	– Sensors.....	65
– Removing.....	70	– System schemes.....	54
Heat transfer medium.....	17, 50	– Valves.....	65
High limit safety cut-out.....	28	Overvoltage.....	44
High pressure sensor.....	65	P	
Hose outlets.....	17, 18, 48, 72	Parameter group selection.....	54
Hot gas temperature sensor.....	65	Parameters	
Hydraulic connection.....	16	– Cooling function.....	57
Hydraulic parameters.....	73	– Electric booster heater.....	58
I		– Energy meters.....	61
Ice store system.....	59	– External functions.....	56
Immersion heater.....	30, 58	– External heat generator.....	58
Inspection.....	49	– Heat pump cascade.....	62
Installation room.....	12	– Heat pump stage 2.....	56
Instantaneous heating water heater.....	16, 58	– Ice store system.....	59
Instructing the system user.....	63	– Immersion heater.....	58
Intended use.....	7	– Instantaneous heating water heater.....	58
Internal components.....	65	– On-site components.....	54
Isolators.....	35	– Other components.....	55
K		– Photovoltaics.....	61
KM-BUS distributor.....	33	– Power generated on site.....	61
L		– Pumps.....	55
Leak test.....	45, 51	– Report.....	73
Liquid gas temperature sensor.....	65	– Smart Grid.....	62
LON communication module.....	33	– Solar DHW heating.....	58
Low pressure sensor.....	65	– Swimming pool water heating.....	59
LV leads.....	21	– Ventilation.....	59, 60
M		Parameter setting.....	54
Main PCB.....	23, 64	Permiss. operating pressure.....	51
Maintenance.....	49	Phase asymmetry.....	44
Maximum temperature limiter.....	25	Phase monitor.....	44, 64
MCB.....	36	– Version 1.....	44
MCBs/fuses.....	68	– Version 2.....	44
Minimum clearances.....	12	– Version 3.....	45
Minimum room volume.....	12	Photovoltaics.....	61
Minimum system pressure.....	51	Pipe entries.....	17
Mixer extension kit.....	25, 33, 55	Positioning.....	14
Modbus.....	33	Power cable.....	19, 36
Modbus distributor.....	33	Power circuits.....	36
Moisture in heat pump module.....	69	Power cuts.....	36
		Power generated on site.....	61
		Power-OFF.....	19, 37
		Power-OFF signal.....	36, 43

Keyword index (cont.)

- Power supply..... 35, 44
 - Compressor..... 36, 37, 64
 - Heat pump control unit..... 36
 - Regulations..... 35
- Power supply with power-OFF
 - With on-site load disconnect..... 39
 - Without on-site load disconnect..... 37
- Premium tariff meter..... 38, 39, 40, 41
- Pressure check..... 51
- Pressure load..... 14
- Primary circuit
 - Filling and venting..... 50
- Primary circuit connection..... 17
- Primary circuit pressure switch..... 45
- Primary pump..... 34
- Product information..... 8
- Programming unit..... 64
 - Installation..... 19
- PWM signal..... 34

- R**
- Radio clock receiver..... 33
- Refrigerant circuit..... 65
- Refrigerant circuit, checking for leaks..... 50
- Refrigerant circuit sensors..... 66
- Remote control..... 33, 56
- Removing top panel..... 16
- Repair work..... 49
- Reports..... 73
- Reports, control parameters..... 73
- Requirements for installation room..... 12
- Residual current device..... 35
- Residual current device (RCD)..... 35
- Resistance curve
 - Temperature sensor NTC 10 k Ω 66
 - Temperature sensor Pt500A..... 66
- Return temperature sensor
 - Primary circuit..... 65, 66
 - Secondary circuit..... 33, 65, 66
- Ripple control receiver..... 38, 39, 40, 41
- Room height..... 12
- Room temperature sensor
 - Cooling circuit..... 33, 66
 - Heating circuit..... 66
- Routing cables..... 20

- S**
- Safety chain..... 44
- Safety connections..... 31
- Safety high pressure switch..... 65
- Safety valve..... 17
- Schrader valve
 - High pressure side..... 65
 - Low pressure side..... 65
- Seal rings, replacing..... 18, 45, 51, 72
- Secondary circuit
 - Connecting..... 17
 - Filling..... 51
 - Filling and venting..... 51
- Secondary pump..... 34
 - Parameters..... 55
- Sensors..... 65
 - Checking..... 66
 - Refrigerant circuit..... 66
- Service menu
 - Activating..... 53
 - Calling up..... 54
 - Deactivating..... 53
- Service termination..... 53
- Sight glass..... 65
- Siting..... 10, 11
- Smart Grid..... 62
 - Connection to EA1 extension..... 43
 - Connection to heat pump control unit..... 43
- Solar DHW heating..... 58
- Specification
 - Brine/water heat pumps..... 84
 - Water/water heat pumps..... 86
- Starting
 - Heat pump..... 51
- Structure-borne noise transmission..... 12
- Suction gas temperature sensor..... 65
- Swimming pool..... 35
- Swimming pool water heating..... 59
- Symbols..... 7
- System pressure check..... 51
- System schemes..... 54
- System user instruction..... 63

- T**
- Temperature limiter..... 25
- Temperature sensors
 - Coefficients, type NTC 10 k Ω 67
 - Coefficients, type Pt500A..... 68
- Terminator..... 33
- Thermal expansion valve..... 65
- Three-phase monitor..... 44
- Tightness test..... 18, 72
- Tilting angle..... 11
- TNC system..... 38, 39, 40, 41
- Top panel removal..... 16
- Top-up water..... 51
- Total weight..... 12
- Transport..... 11
- Transport bracket..... 69
 - Removal..... 15
- Transport brackets..... 69

- U**
- Underfloor heating..... 25
- Underfloor heating circuit..... 25
- Undervoltage..... 44
- Use of power generated on site..... 36

Keyword index (cont.)

V

Vapour injection	
– Heat exchanger.....	65
– Solenoid valve.....	65
– Thermal expansion valve.....	65
VDE regulations.....	35
Ventilation.....	59, 60
Venting	
– Primary side.....	50
– Secondary side.....	51
Vitocom 100.....	56
Vitocomfort 200.....	56

W

Wall clearances.....	12
Warranty.....	52
Water/water heat pump.....	8
Water quality.....	51
Weight.....	12
Wiring chamber.....	64

Viessmann Werke GmbH & Co. KG
D-35107 Allendorf
Telephone: +49 6452 70-0
Fax: +49 6452 70-2780
www.viessmann.com



Viessmann Limited
Hortonwood 30, Telford
Shropshire, TF1 7YP, GB
Telephone: +44 1952 675000
Fax: +44 1952 675040
E-mail: info-uk@viessmann.com

5855006 Subject to technical modifications.