

Installation and service instructions for contractors

VIESMANN

Vitocal 222-G
Type BWT-M 221.B06 to B10

Compact heat pump with integral DHW cylinder, 230 V~



VITOCAL 222-G



Safety instructions

 Please follow these safety instructions closely to prevent accidents and material losses.

Safety instructions explained

 **Danger**
This symbol warns against the risk of injury.

 **Please note**
This symbol warns against the risk of material losses and environmental pollution.

Note
Details identified by the word "Note" contain additional information.

Target group

These instructions are exclusively intended for authorised contractors.

- Work on the refrigerant circuit may only be carried out by authorised refrigeration engineers.
- Work on electrical equipment must only be carried out by a qualified electrician.
- The system must be commissioned by the system installer or a qualified person authorised by the installer.

Regulations to be observed

- National installation regulations
- Statutory regulations for the prevention of accidents
- Statutory regulations for environmental protection
- Codes of practice of the relevant trade associations
- Relevant country-specific safety regulations

Safety instructions (cont.)**Safety instructions for working on the system****Working on the system**

- Isolate the system from the power supply, e.g. by removing the separate fuse or by means of a mains isolator, and check that it is no longer live.

Note

In addition to the control circuit there may be several power circuits.

 **Danger**

Contact with live components can result in severe injuries. Some components on PCBs remain live even after the power supply has been switched off.

Prior to removing covers from the appliances, wait at least 4 minutes until the voltage has completely dropped out.

- Safeguard the system against reconnection.
- Wear suitable personal protective equipment when carrying out any work.

 **Danger**

Hot surfaces and fluids can lead to burns or scalding.

- Before maintenance and service work, switch OFF the appliance and let it cool down.
- Never touch hot surfaces on the appliance, fittings or pipework.

 **Danger**

Risk of fire: Electrostatic discharge can cause sparks which may be ignited by escaping, flammable refrigerant (R32).

Before beginning work, touch earthed objects, such as heating or water pipes, to discharge any static.

 **Please note**

Electronic assemblies can be damaged by electrostatic discharge. Prior to commencing work, touch earthed objects such as heating or water pipes to discharge static loads.

Work on the refrigerant circuit

Refrigerants are air displacing, colourless, odourless gases.

- R32 forms flammable mixtures with air.
- R410A is not flammable.

 **Danger**

Direct contact with liquid and gaseous refrigerant can cause serious damage to health.

- Avoid direct contact with liquid and gaseous refrigerant.
- Wear personal protective equipment when handling liquid and gaseous refrigerant.

 **Danger**

Unregulated escape of refrigerant in enclosed spaces can lead to breathing difficulties and suffocation.

- Never breathe in refrigerant vapours.
- Ensure adequate ventilation in enclosed spaces.

Perform the following measures before beginning work on the refrigerant circuit:

- Check the refrigerant circuit for leaks.
- Ensure very good ventilation especially in the floor area and sustain this for the duration of the work.

Safety instructions (cont.)

- Inform all persons in the vicinity of the system about the type of work to be carried out.
- Secure the area surrounding the work area.

Further measures before starting work on the refrigerant circuit with flammable refrigerants (R32):

- Remove all flammable materials and ignition sources from the immediate vicinity of the heat pump.
- Before, during and after the work, check the surrounding area for escaping refrigerant using a suitable refrigerant detector.
This refrigerant detector must not generate any sparks and must be suitably sealed.
- A CO₂ or powder extinguisher must be to hand in the following cases:
 - Refrigerant is being topped up.
 - Soldering or welding work is being carried out.
- Display signs prohibiting smoking.

Danger

Damage to the refrigerant circuit can cause refrigerant to enter the hydraulic system. This can cause serious damage to health.

After completion of the work, professionally vent the hydraulic system on the primary and secondary sides.

Repair work

Please note

Repairing components that fulfil a safety function can compromise the safe operation of the system. Replace faulty components only with genuine Viessmann spare parts.

Auxiliary components, spare and wearing parts

Please note

Spare and wearing parts that have not been tested together with the system can compromise its function. Installing non-authorised components and making non-approved modifications or conversions can compromise safety and may invalidate our warranty. For replacements, use only original spare parts supplied or approved by Viessmann.

Safety instructions for operating the system

What to do if water escapes from the appliance

Danger

If water escapes from the appliance there is a risk of electrocution. Switch OFF the heating system at the external isolator (e.g. fuse box, domestic distribution board).



Danger

If water escapes from the appliance there is a risk of scalding. Never touch hot heating water.

Index

1. Information	Disposal of packaging	7
	Symbols	7
	Intended use	7
	Product information	8
	■ System examples	8
	■ Spare parts lists	8
2. Preparing for installation	Requirements concerning on-site connections	9
	Siting and transport requirements	11
	■ Transport	11
	■ Installation room requirements	11
3. Installation sequence	Siting the heat pump	13
	■ Removing the front panels	13
	■ Removing the heat pump module	14
	■ Installing the heat pump module	17
	■ Levelling the heat pump	18
	Hydraulic connections	18
	■ Connecting the primary/secondary circuits	18
	■ Connecting the cooling circuit	20
	■ Connections on the DHW side	21
	Electrical connection	22
	■ Preparing the electrical connections	22
	■ Routing the cables to the wiring chamber	24
	■ Connecting the Vitoconnect (accessories)	25
	■ Overview of electrical connections	27
	■ Main PCB (function components 230 V~)	28
	■ Expansion PCB on main PCB (230 V~ components)	31
	■ Luster terminals (message and safety connections)	32
	■ Controller and sensor PCB (low voltage connections)	34
	■ Connecting a temperature limiter to restrict the maximum temperature of underfloor heating circuit	35
	■ Swimming pool heating	38
	Power supply	39
	■ Heat pump control unit power supply 230 V~	40
	■ Compressor power supply 230 V~	40
	■ Instantaneous heating water heater power supply 230 V~	41
	■ Power supply with power-OFF: Without on-site load disconnection ...	41
	■ Power supply with power-OFF: With on-site load disconnection	42
	■ Mains power supply in conjunction with self-consumption	43
	■ Smart Grid	43
	Make connections at terminals X3.8/X3.9	45
	Closing the heat pump	45
4. Commissioning, inspection, maintenance	Steps - commissioning, inspection and maintenance	46
5. Maintenance	Overview of electrical components	68
	Opening the programming unit	69
	Overview of internal components	70
	Draining heat pump on the secondary side	71
	Checking the temperature sensors	71
	■ Viessmann NTC 10 kΩ (blue marking)	72
	■ Viessmann Pt500A (green marking)	73
	■ NTC 10 kΩ (no marking)	74
	Checking the fuses	74
	Appliance is too noisy	75
6. Commissioning/service reports	Hydraulic parameters report	76
	Control parameter report	76

Index









Index (cont.)

7. Specification	Specification for brine/water heat pumps	87
	Specification for water/water heat pumps	92
8. Appendix	Commissioning order	93
9. Declaration of Conformity	Declaration of conformity	94
10. Keyword index	95







Disposal of packaging

Please dispose of packaging waste in line with statutory regulations.

Symbols

Symbol	Meaning
	Reference to other document containing further information
	Step in a diagram: The numbers correspond to the order in which the steps are carried out.
	Warning of material losses and environmental pollution
	Live electrical area
	Pay particular attention.
	<ul style="list-style-type: none"> ▪ Component must audibly click into place. or ▪ Acoustic signal
	<ul style="list-style-type: none"> ▪ Fit new component. or ▪ In conjunction with a tool: Clean the surface.
	Dispose of component correctly.
	Dispose of component at a suitable collection point. Do not dispose of component in domestic waste.

The steps in connection with commissioning, inspection and maintenance are found in the "Commissioning, inspection and maintenance" section and identified as follows:

Symbol	Meaning
	Steps required during commissioning
	Not required during commissioning
	Steps required during inspection
	Not required during inspection
	Steps required during maintenance
	Not required during maintenance

Intended use

The appliance is only intended to be installed and operated in sealed unvented heating systems that comply with EN 12828, with due attention paid to the associated installation, service and operating instructions.

Depending on the version, the appliance can only be used for the following purposes:

- Central heating
- Central cooling
- DHW heating

The range of functions can be extended with additional components and accessories.

Intended use presupposes that a fixed installation in conjunction with permissible, system-specific components has been carried out.

Commercial or industrial usage for a purpose other than central heating/cooling or DHW heating shall be deemed inappropriate.

Intended use (cont.)

Incorrect usage or operation of the appliance (e.g. the appliance being opened by the system user) is prohibited and will result in an exclusion of liability. Incorrect usage also occurs if the components in the heating system are modified from their intended function.

Note

The appliance is intended exclusively for domestic or semi-domestic use, i.e. even users who have not had any instruction are able to operate the appliance safely.

Product information**Structure**

The Vitocal 222-G is a compact heat pump with a brine/water heat pump module and integral DHW cylinder. The heat pump module can be removed for transporting the appliance.

To back up the heat pump module an instantaneous heating water heater has been installed as a further heat source. This can be activated when there is a high heat demand.

Refrigerant circuit

The refrigerant circuit has an electronic expansion valve with an independent control circuit (refrigerant circuit controller).

Hydraulics

The compact heat pump is equipped with high efficiency circulation pumps for the primary and secondary circuits. The integral 3-way diverter valve for "central heating/DHW heating" changes over between central heating and DHW heating.

Central heating

The compact heat pump can supply up to 3 heating circuits – 1 heating circuit without and 2 heating circuits with mixer. The mixer extension kit (accessories) is required to control the mixer for the second heating circuit with mixer (M3/HC3).

Room cooling

Rooms can be cooled either via 1 heating/cooling circuit or 1 separate cooling circuit. Hydraulic accessories are required for this, e.g. NC-Box with mixer.

Heat pump control unit

The entire system is monitored and controlled by the integral Vitotronic 200 heat pump control unit, type WO1C.

System examples

Available system examples: See www.viessmann-schemes.com.

Spare parts lists

Information about spare parts can be found at www.viessmann.com/etapp or in the Viessmann spare part app.



Requirements concerning on-site connections

Primary circuit connections to the right

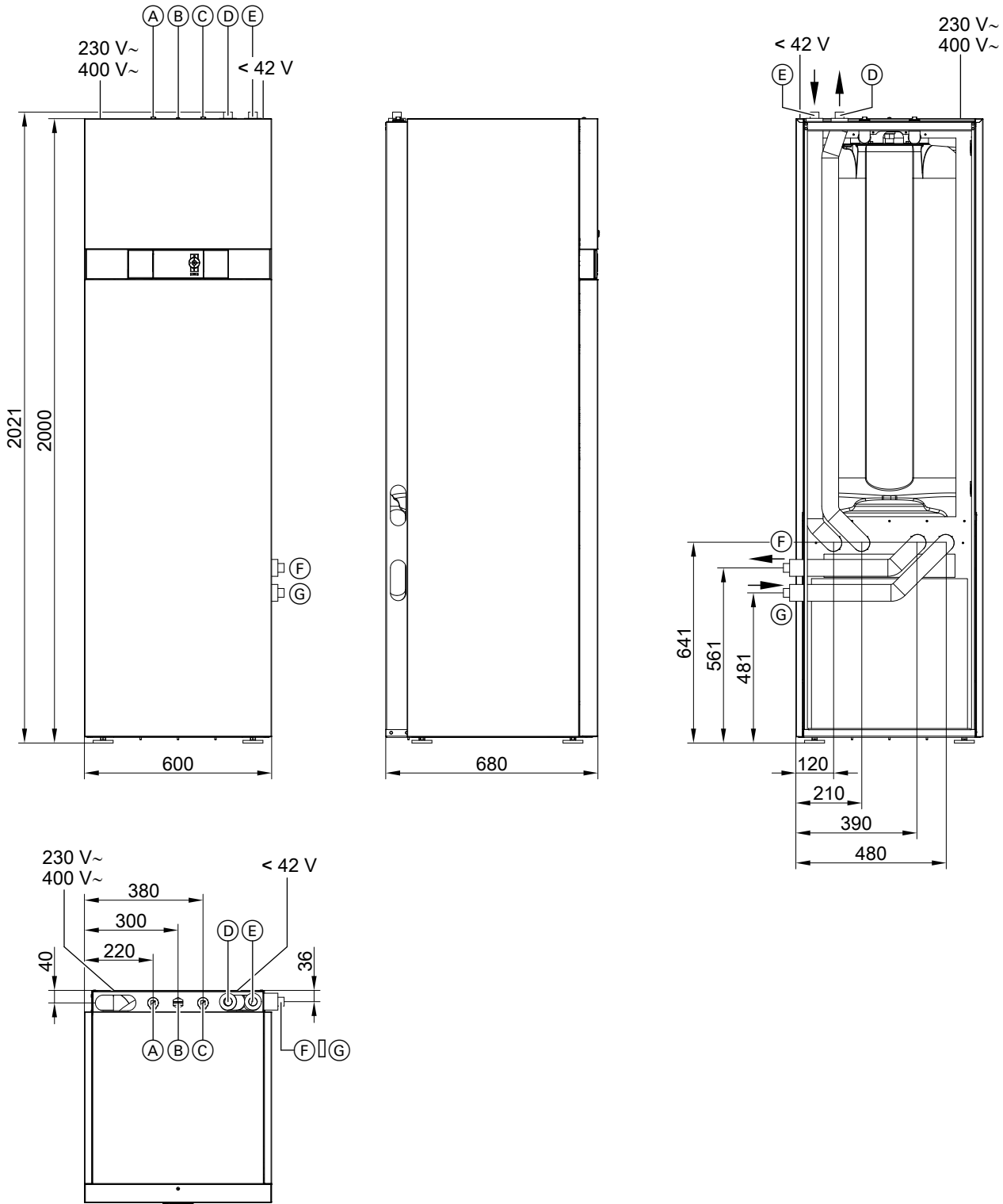

Fig. 1

- (A) Cold water
- (B) DHW circulation
- (C) DHW
- (D) Secondary circuit flow (heating water)
- (E) Secondary circuit return (heating water)
- (F) Primary circuit return (heat pump brine outlet)
- (G) Primary circuit flow (heat pump brine inlet)

Primary circuit connections to the left

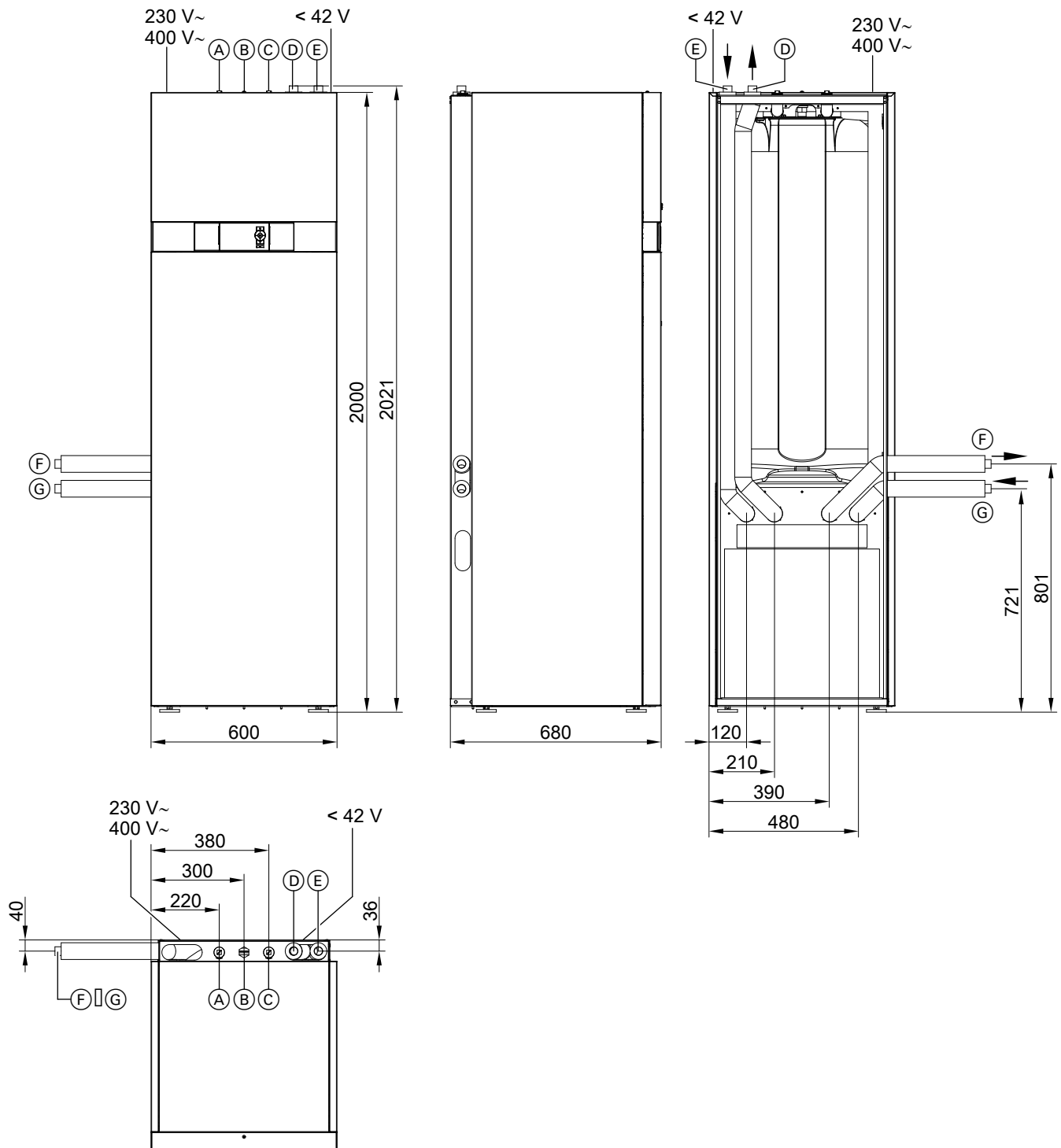

Fig. 2

- (A) Cold water
- (B) DHW circulation
- (C) DHW
- (D) Secondary circuit flow (heating water)
- (E) Secondary circuit return (heating water)
- (F) Primary circuit return (heat pump brine outlet)
- (G) Primary circuit flow (heat pump brine inlet)

Siting and transport requirements

Transport

- ! Please note**
Impacts, compression and tensile loads can cause damage to the outside panels of the appliance.
Never put weight on the top, front or side panels of the appliance.

- ! Please note**
Tilting the compressor at a steep angle inside the heat pump can result in appliance damage.
Max. tilting angle: 45° for a very short time

For handling purposes, the heat pump module can be removed: See page 14.

Installation room requirements

- ! Please note**
Unfavourable ambient conditions can lead to malfunctions and appliance damage.

The installation room must be dry and free from the risk of frost:

- Ensure ambient temperatures between 0 and 35 °C.
- Max. 70 % relative humidity (corresponds to an absolute humidity of approx. 25 g water vapour/kg dry air)



Danger
Dust, gases and vapours can be damaging to health and trigger explosions.
Avoid dust, gases and vapours in the installation room.

- ! Please note**
Overloading the floor can result in damage to the building structure.
Observe the permissible floor load. Take the total weight of the appliance into account.

Minimum room volume (to EN 378):

Type	Refrigerant charge in kg	Minimum room volume in m ³
BWT-M 221.B06	1.40	3.2
221.B08	1.95	4.5
221.B10	2.40	5.5

Minimum clearances

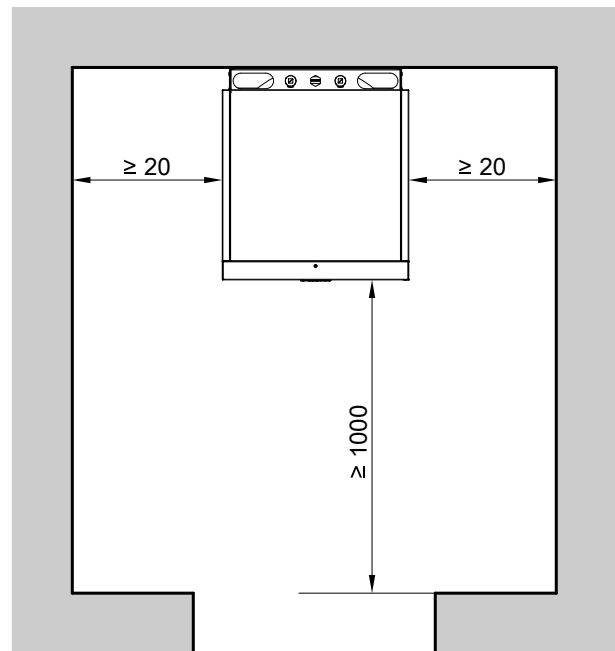

Fig. 3



Observe engineering information.
Brine/water heat pump technical guide

Minimum room height

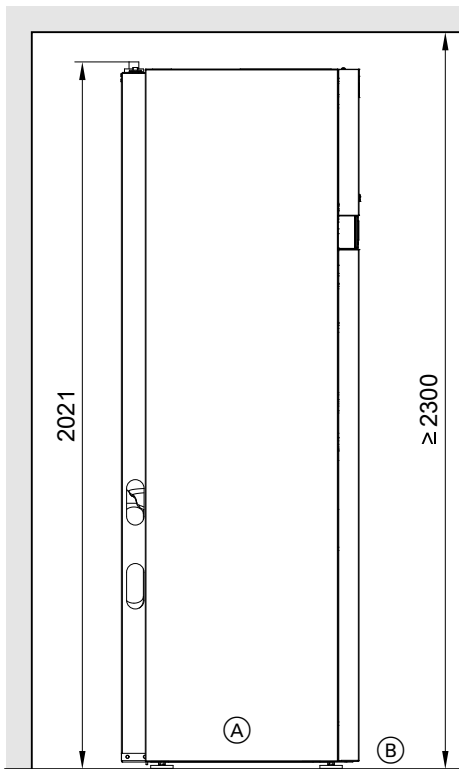

Fig. 4

- Ⓐ Compact heat pump
- Ⓑ Finished floor level or top edge of platform for unfinished floors

Note

If applicable, remove the packaging box upwards before installation.

Pressure points

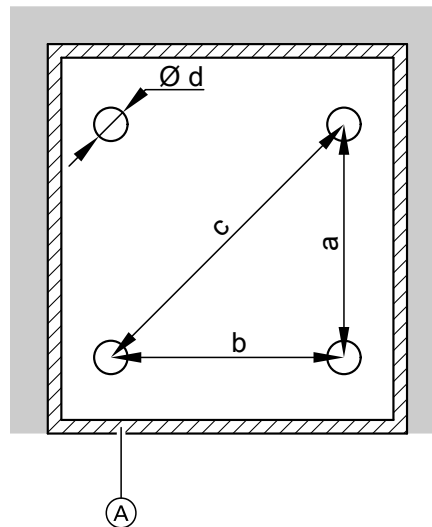

Fig. 5

- Ⓐ Partition joint with edge insulation strip as part of the floor construction
- a 484 mm
- b 480 mm
- c 657 mm
- d 64 mm

Total weight with full DHW cylinder

Type	Weight in kg	
BWT-M	221.B06	497
	221.B08	502
	221.B10	508

Each pressure point (each with an area of 3217 mm²) is subject to a load of up to 132 kg.

Siting the heat pump

To prevent the transmission of structure-borne noise, never site the appliance above ceilings with wooden joists, e.g. in the attic.

Removing the front panels

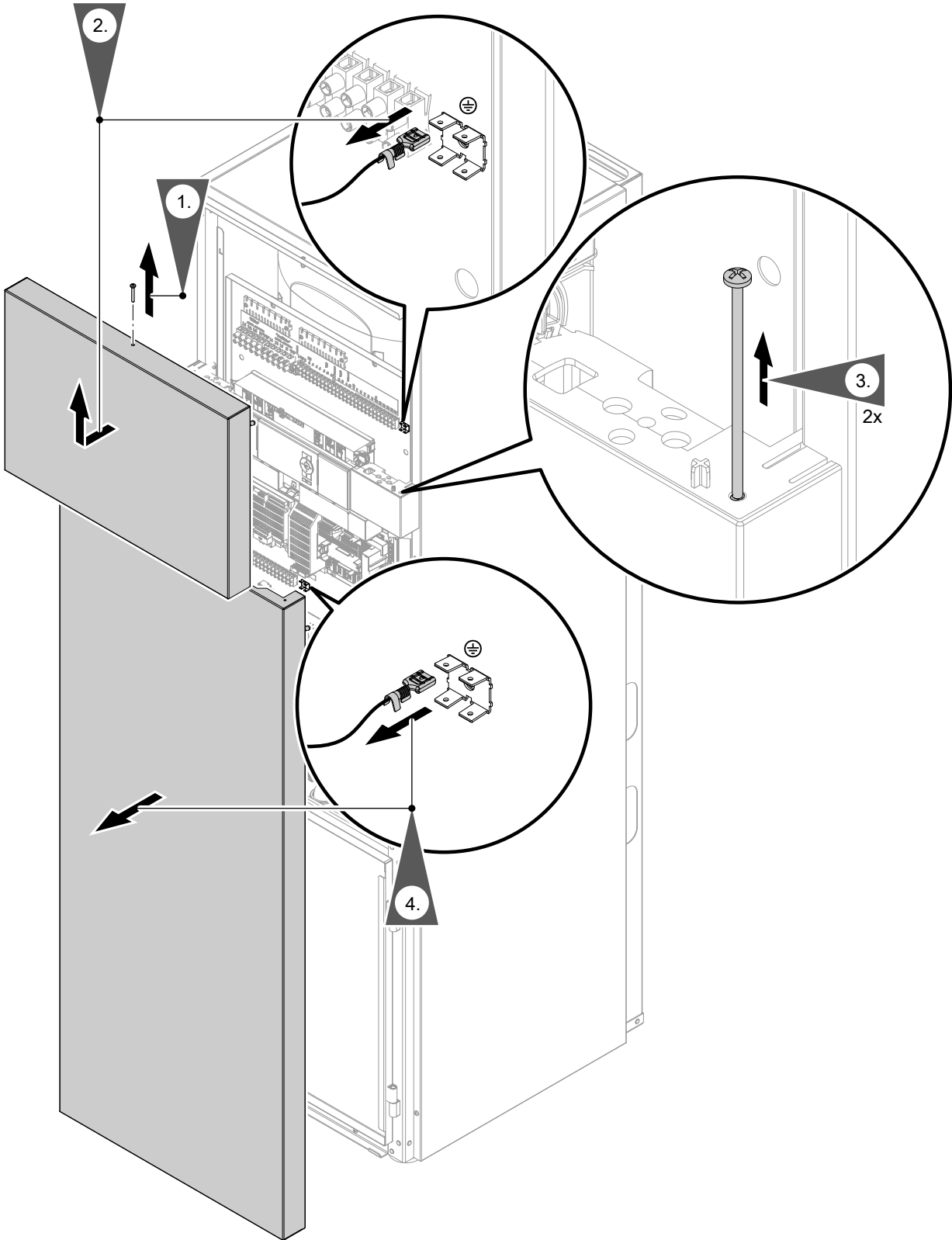

Installation

Fig. 6

Removing the heat pump module

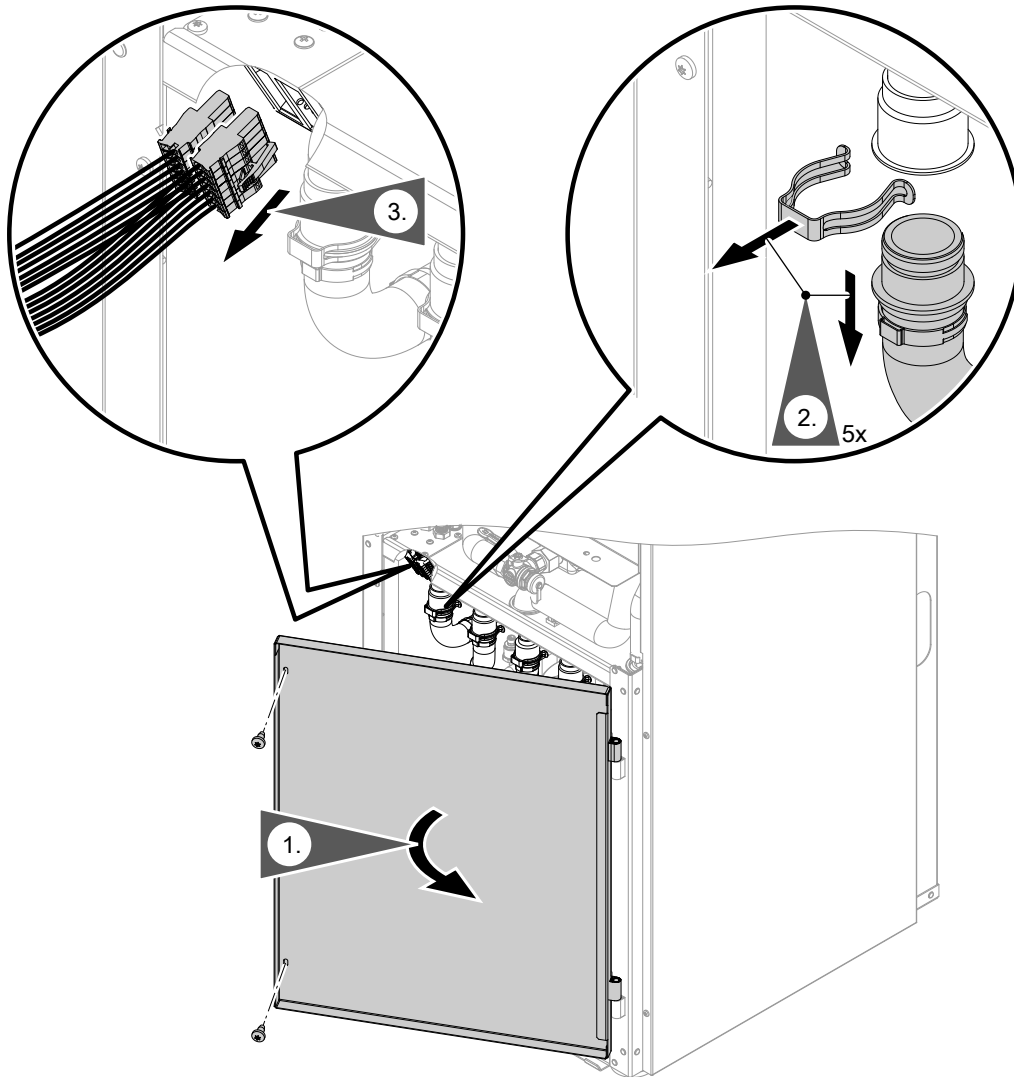

Fig. 7

Siting the heat pump (cont.)

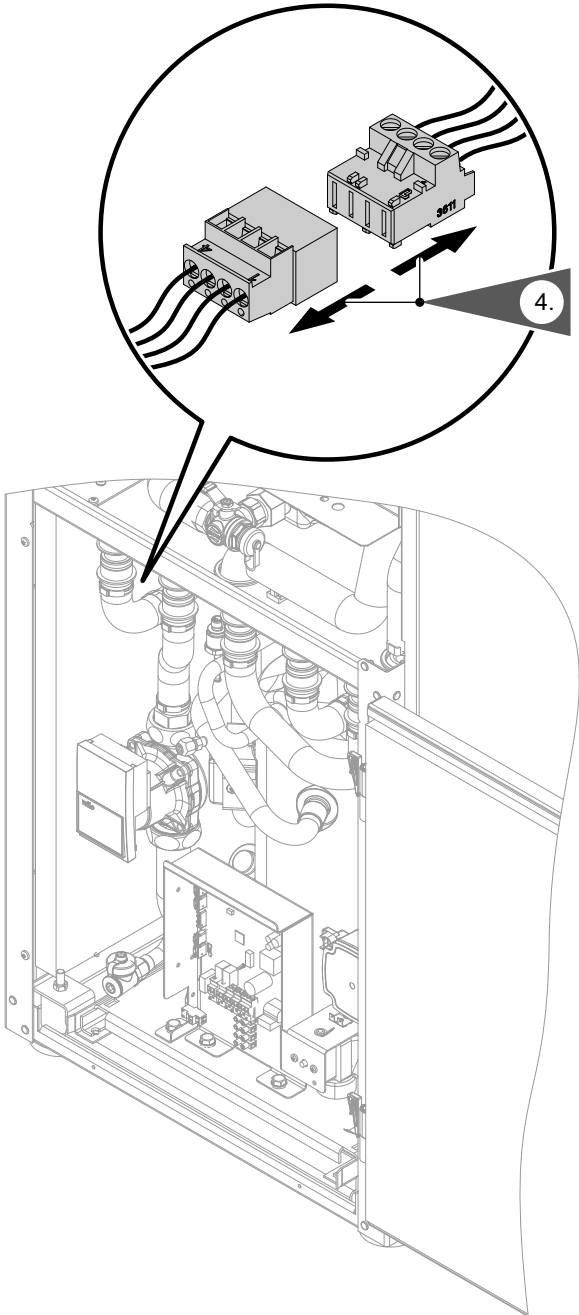

Fig. 8

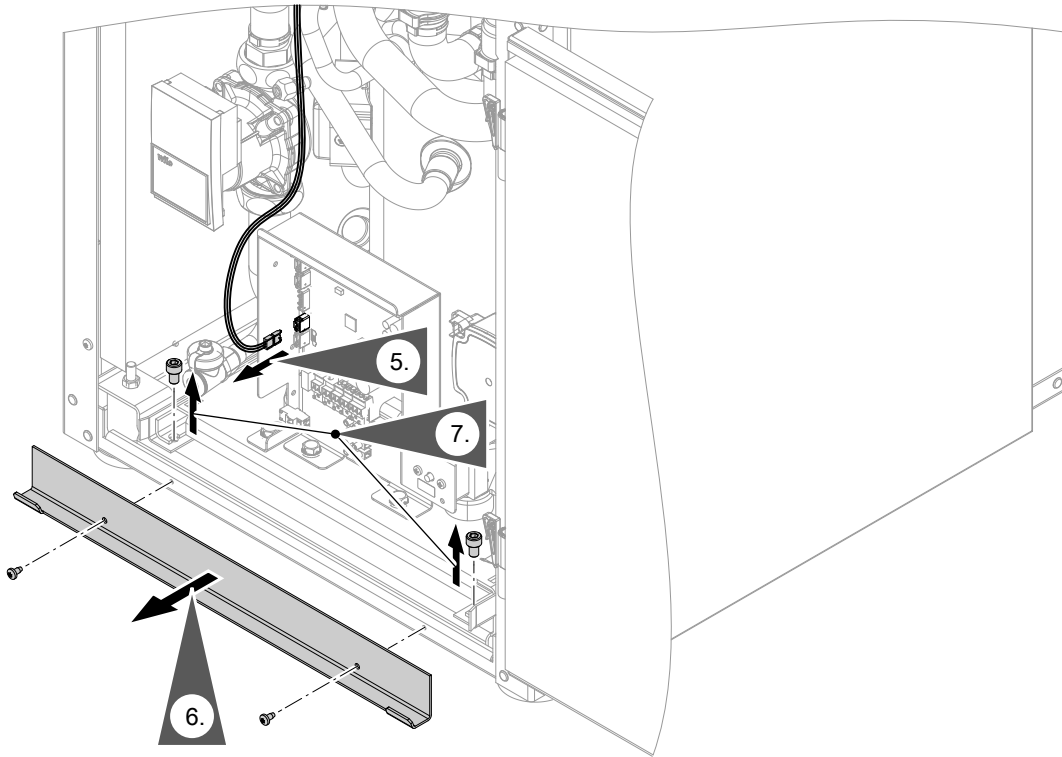

Fig. 9

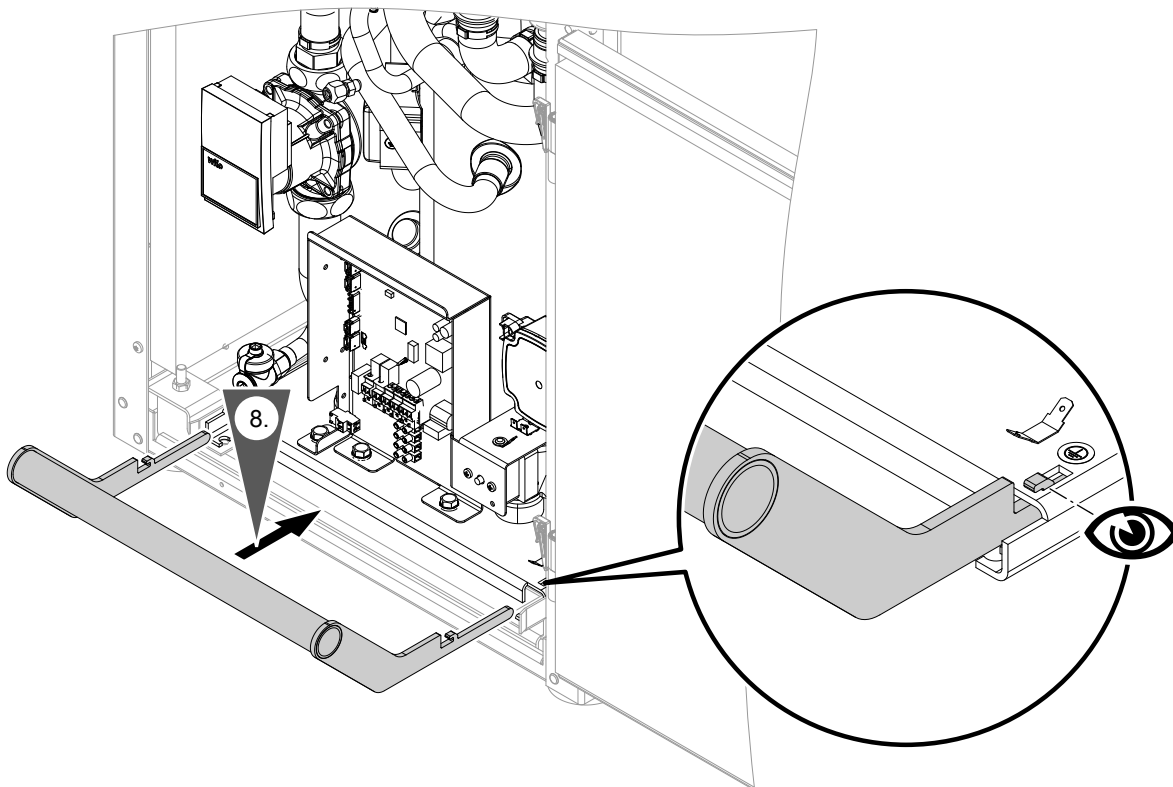
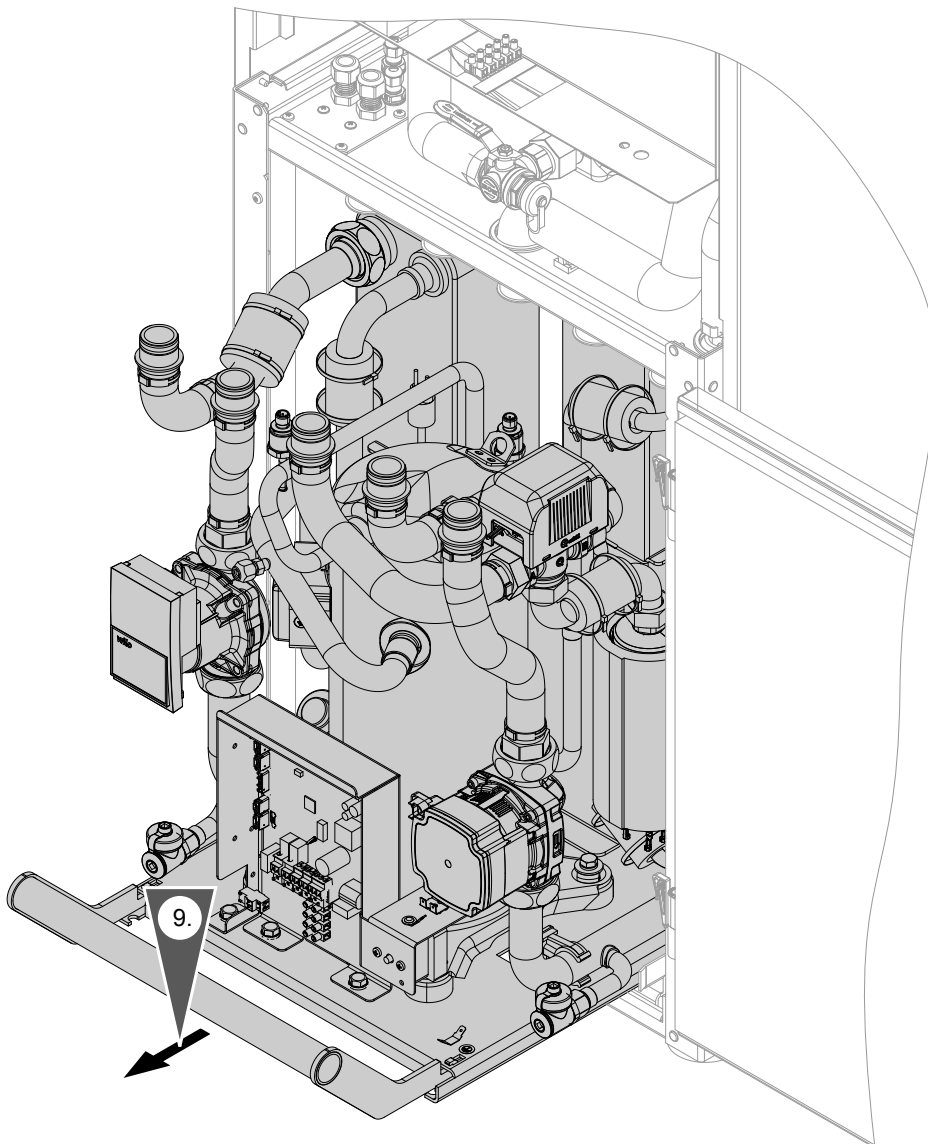

Fig. 10

Siting the heat pump (cont.)*Fig. 11***Installing the heat pump module**

Refit the heat pump module in reverse order to the removal sequence: See individual steps from page 14.

Installation sequence

Siting the heat pump (cont.)

Levelling the heat pump

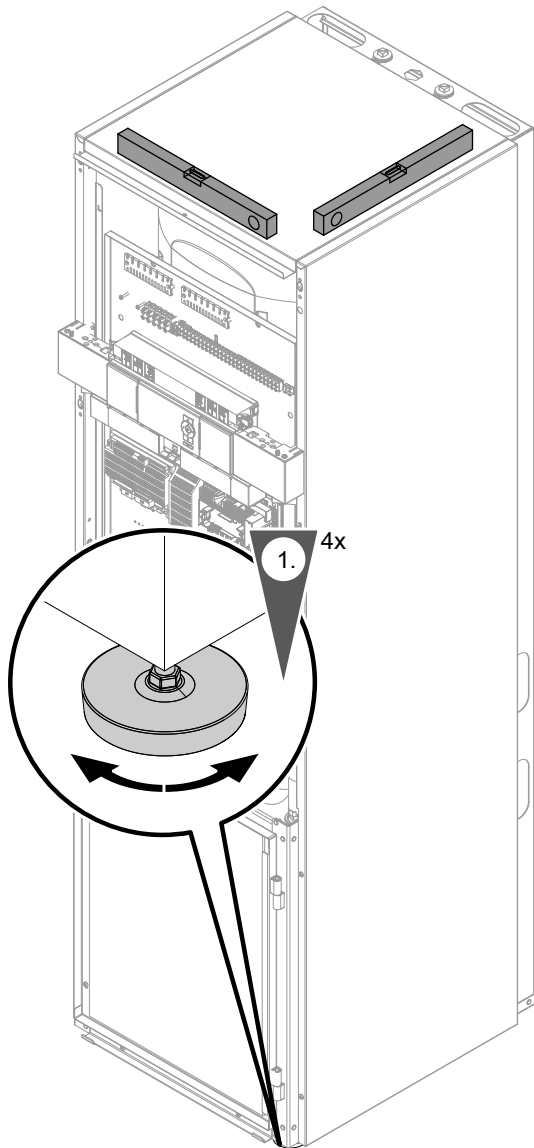

Fig. 12

Hydraulic connections

Connecting the primary/secondary circuits

Fitting the primary/secondary circuit connection set (standard delivery)

Note

We recommend fitting shut-off devices to the connection set on site. This will allow the primary and secondary circuit to be shut off for maintenance work.

Hydraulic connections (cont.)

Primary circuit connections to the right

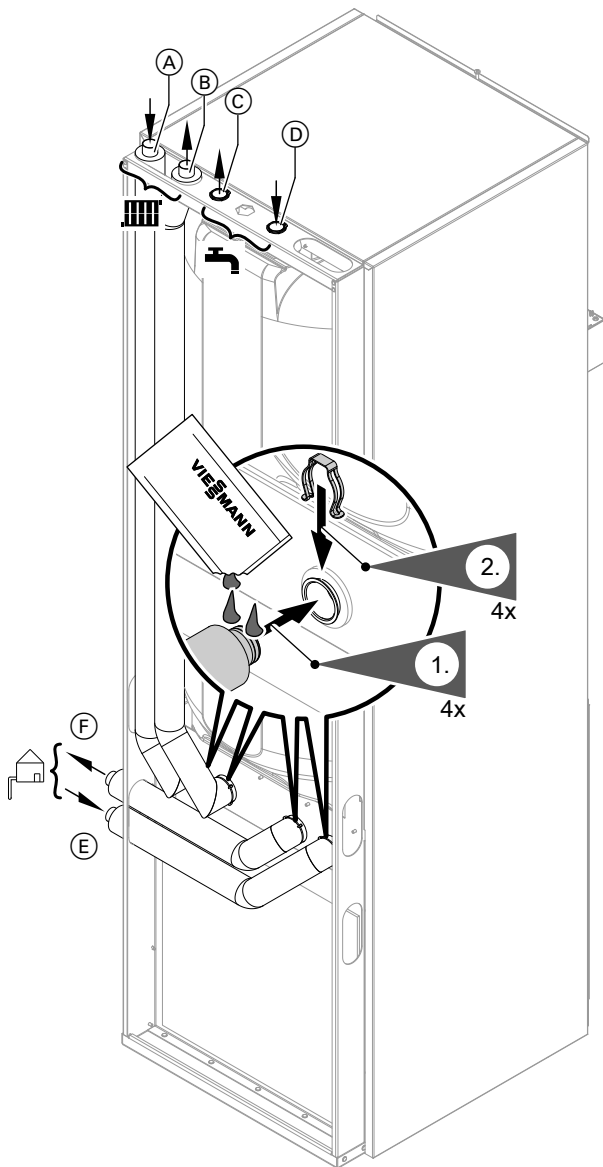

Fig. 13

Primary circuit connections to the left

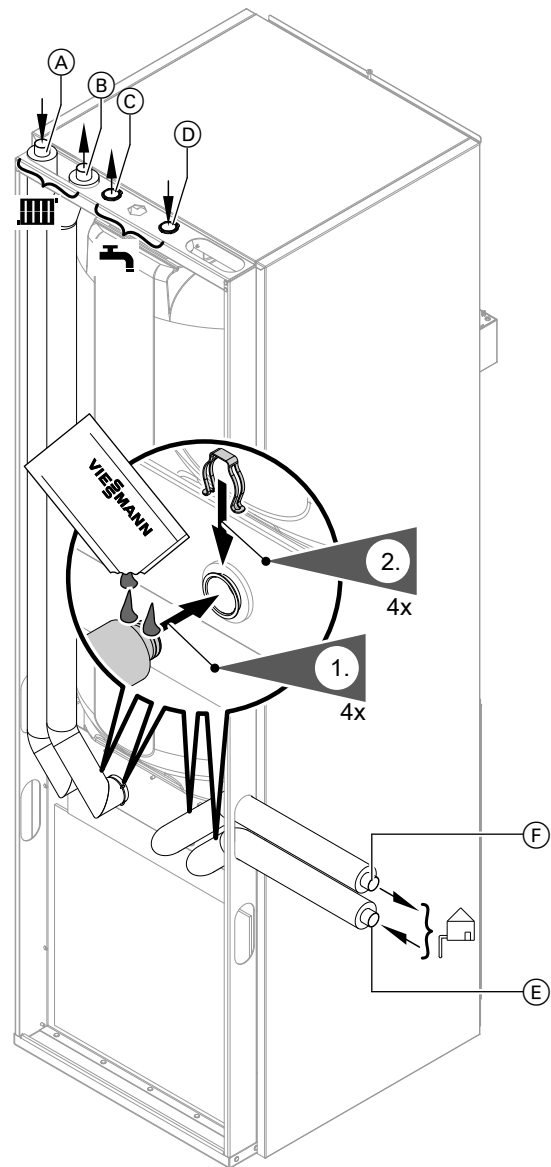

Fig. 14

Pos.	Meaning	Connection
Ⓐ	Secondary circuit return (heating water)	Cu 28 x 1.5 mm
Ⓑ	Secondary circuit flow (heating water)	Cu 28 x 1.5 mm
Ⓒ	DHW	Rp 3/4 (female thread)
Ⓓ	Cold water	Rp 3/4 (female thread)
Ⓔ	Primary circuit flow (heat pump brine inlet)	Cu 28 x 1.5 mm
Ⓕ	Primary circuit return (heat pump brine outlet)	Cu 28 x 1.5 mm

Pos.	Meaning	Connection
Ⓐ	Secondary circuit return (heating water)	Cu 28 x 1.5 mm
Ⓑ	Secondary circuit flow (heating water)	Cu 28 x 1.5 mm
Ⓒ	DHW	Rp 3/4 (female thread)
Ⓓ	Cold water	Rp 3/4 (female thread)
Ⓔ	Primary circuit flow (heat pump brine inlet)	Cu 28 x 1.5 mm
Ⓕ	Primary circuit return (heat pump brine outlet)	Cu 28 x 1.5 mm

Connecting the primary circuit

- !** **Please note**
- The heat transfer medium can cause corrosion damage to on-site lines and components. The components and lines used must be resistant to the heat transfer medium. Never use zinc-plated/galvanised pipes.

1. Equip the primary circuit with an expansion vessel and safety valve, in accordance with DIN 4757.

Note

- *The expansion vessel must be approved to DIN 4807. The diaphragms of the expansion vessel and safety valve must be suitable for the heat transfer medium.*
- *The blow down and drain pipes should exit into a container. This container must be able to hold the maximum possible expansion volume of the heat transfer medium.*

2. Ensure adequate thermal and anti-vibration insulation where pipes penetrate walls.
3. Connect the primary pipes to the heat pump.



Please note

Mechanically loaded hydraulic connections lead to leaks, vibrations and appliance damage. Connect on-site lines so that they are free of load and torque stress.

4. Insulate pipes inside the building to prevent heat and vapour diffusion.
5. Fill the primary circuit with Viessmann heat transfer medium and vent.

Note

Ensure frost protection down to at least $-15\text{ }^{\circ}\text{C}$. Viessmann heat transfer medium is a ready-mixed ethylene glycol-based medium. It contains inhibitors for corrosion protection. The heat transfer medium can be used at temperatures down to $-16\text{ }^{\circ}\text{C}$.

Connecting the secondary circuit

1. Equip the secondary circuit with an expansion vessel and safety valve on site, in accordance with DIN 4757. Fit the safety valve to the on-site line in the heating water return.

Note

The expansion vessel must be approved to EN 13831.

2. Connect the secondary lines to the heat pump.



Please note

Mechanically loaded hydraulic connections lead to leaks, vibrations and appliance damage. Connect on-site lines so that they are free of load and torque stress.

3. Thermally insulate lines inside the building.

Note

- *For underfloor heating circuits, install a temperature limiter to restrict the maximum temperature in the underfloor heating system: See chapter "Connecting a temperature limiter to restrict the maximum temperature of underfloor heating circuit".*
- *Ensure the minimum flow rate, e.g. with an overflow valve: See chapter "Specification".*

Connecting the cooling circuit

An NC-Box (accessories) is required for cooling mode. Connect the heating/cooling circuit or separate cooling circuit to the NC-Box.



Installation instructions "NC-Box"

Hydraulic connections (cont.)

Connections on the DHW side

For connecting the DHW side, observe DIN 1988 and DIN 4753 (CH: SVGW regulations).

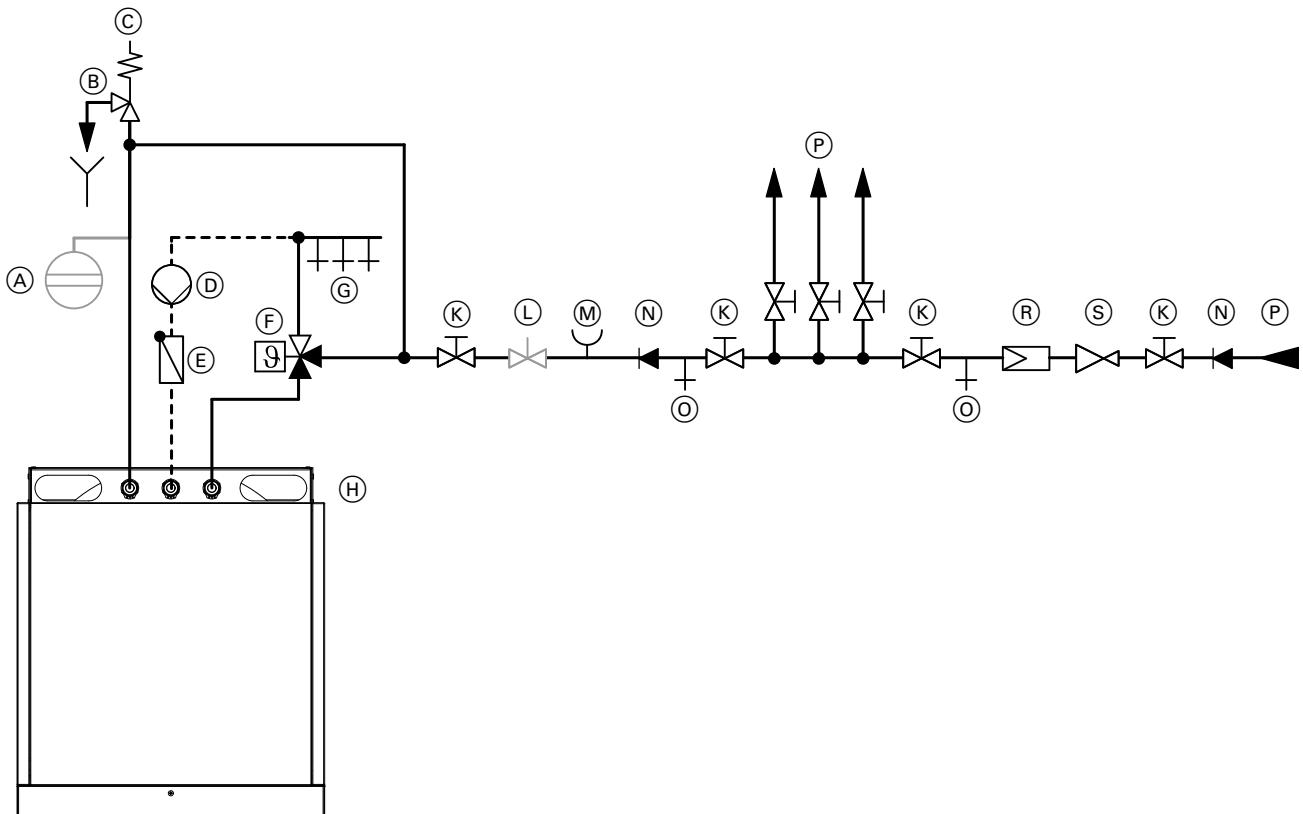

Fig. 15

- (A) Expansion vessel, suitable for drinking water
- (B) Visible discharge pipe outlet point (tundish)
- (C) Safety valve
- (D) DHW circulation pump
- (E) Spring-loaded check valve
- (F) Automatic thermostatic mixing valve
- (G) DHW
- (H) Heat pump terminal area (plan view)

- (K) Shut-off valve
- (L) Flow regulating valve
- (M) Pressure gauge connection
- (N) Non-return valve/pipe separator
- (O) Drain valve
- (P) Cold water
- (R) Drinking water filter
- (S) Pressure reducer

Safety valve

The DHW cylinder **must** have a safety valve to protect against unduly high pressure.

Recommendation: Install safety valve above top edge of cylinder. This means the DHW cylinder will not need to be drained when working on the safety valve.

CH: According to W3 "Principles for creating potable water installations", safety valves must be drained directly via a visible unrestricted drain or via a short outlet line to the drain network.

Drinking water filter

According to DIN 1988-2, a drinking water filter must be installed in systems with metal pipework. Viessmann also recommends the installation of a drinking water filter when using plastic pipes to DIN 1988 to prevent contaminants entering the DHW system.

Automatic thermostatic mixing valve

With appliances that heat DHW to temperatures above 60 °C, an automatic thermostatic mixing valve must be installed in the DHW line as protection against scalding.

This also particularly applies when connecting solar thermal systems.

Hydraulic connections (cont.)

Preparing the connections on the DHW side

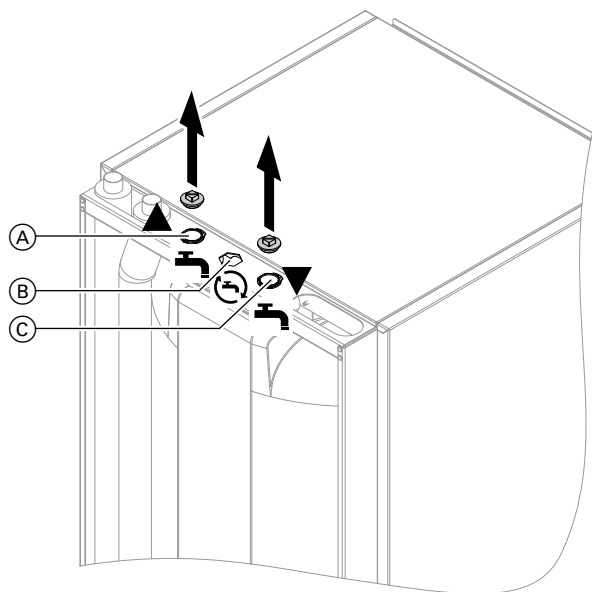



Fig. 16

Pos.	Meaning	Connection (female thread)
Ⓐ	DHW	Rp 3/4
Ⓑ	Lead-through for DHW circulation connection: See chapter "Connecting the DHW circulation pipe".	Rp 3/4
Ⓒ	Cold water	Rp 3/4

Connecting the DHW circulation pipe

DHW circulation pump outside the appliance

Install the DHW circulation connection set (supplied) **inside** the appliance.

 Installation instructions "DHW circulation connection set" (supplied)

DHW circulation pump inside the appliance

Install the DHW circulation pump connection set (accessories) **inside** the appliance.

 Installation instructions "DHW circulation pump connection set"

Electrical connection

Preparing the electrical connections

Cables

- For cable lengths and cable cross-sections: See the following tables.
- For accessories:
 - Cables with the required number of cores for external connections.
 - Prepare an on-site distribution box.



Danger

Damaged wiring insulation wiring can lead to serious injury from electrical current and result in appliance damage.
Route cables so that they cannot touch very hot, vibrating or sharp-edged components.



Danger

Incorrect wiring can lead to serious injury from electrical current and result in appliance damage.

Take the following measures to prevent drifting of wires into the adjacent voltage area:

- Route LV leads < 42 V separately from cables > 42 V/230 V~/400 V~ and secure with cable ties.
- Strip as little of the insulation as possible, directly before the terminals. Bundle cables/ leads close to the corresponding terminals.
- If 2 components are connected to the same terminal, press both cores together in a **single** wire ferrule.

Electrical connection (cont.)**Required cable lengths in the heat pump plus wall clearance****Cable lengths**

- Required cable length inside the appliance plus distance to wall:
1.8 m
- Height of wall outlet:
1900 mm: See "Technical guide for heat pumps".

Recommended power cables

Power supply	Cable	Max. cable length
Heat pump control unit 230 V~	▪ Without power-OFF	3 x 1.5 mm ²
	▪ With power-OFF	5 x 1.5 mm ²
Compressor 230 V~	3 x 2.5 mm ²	25 m
Instantaneous heating water heater 230 V~	7 x 2.5 mm ²	25 m

Routing the cables to the wiring chamber

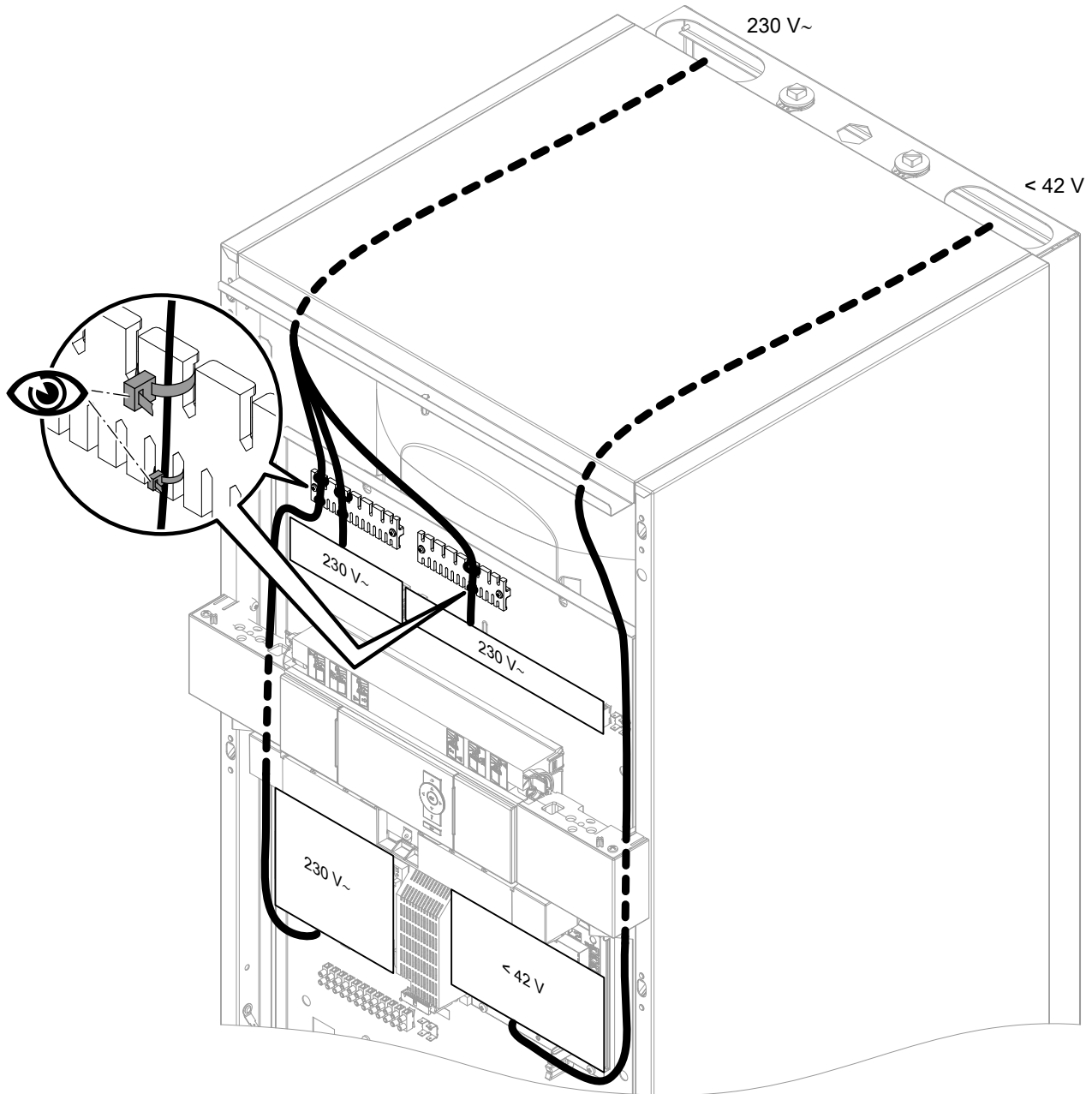

Fig. 17

Electrical connection (cont.)

Connecting the Vitoconnect (accessories)

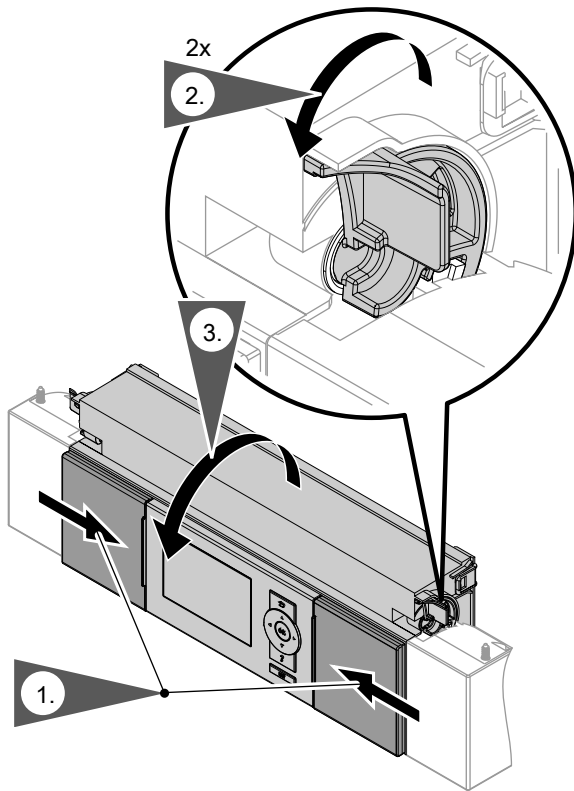

Fig. 18

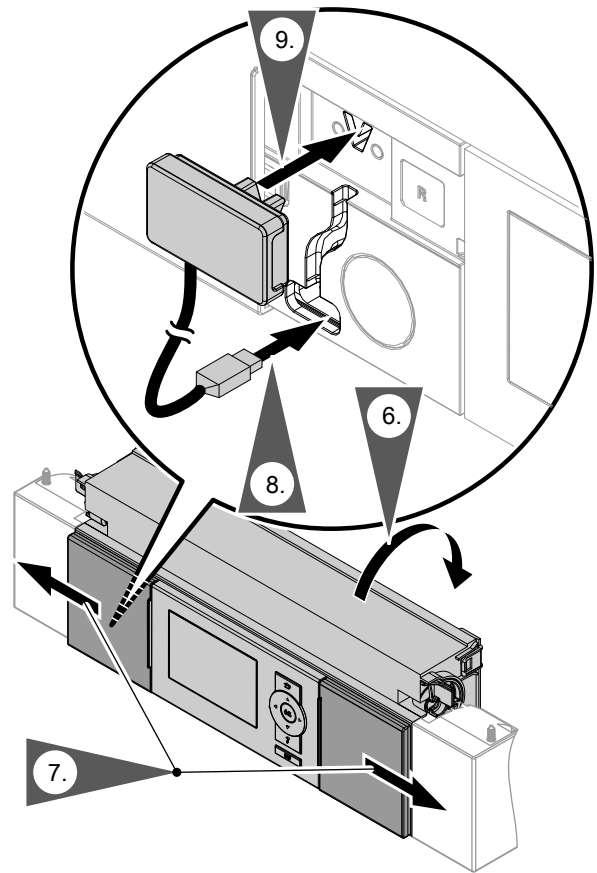

Fig. 20

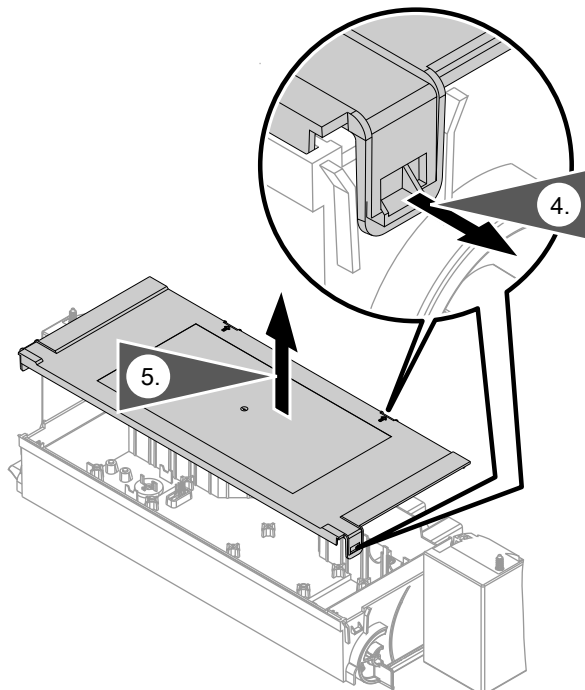

Fig. 19

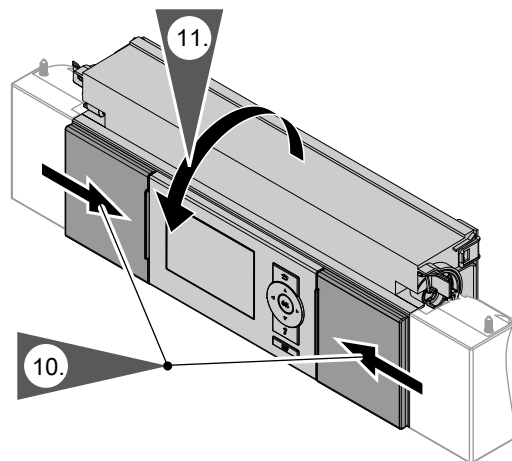

Fig. 21

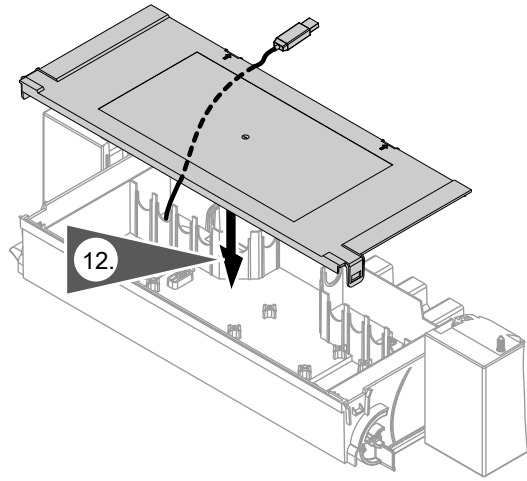

Fig. 22

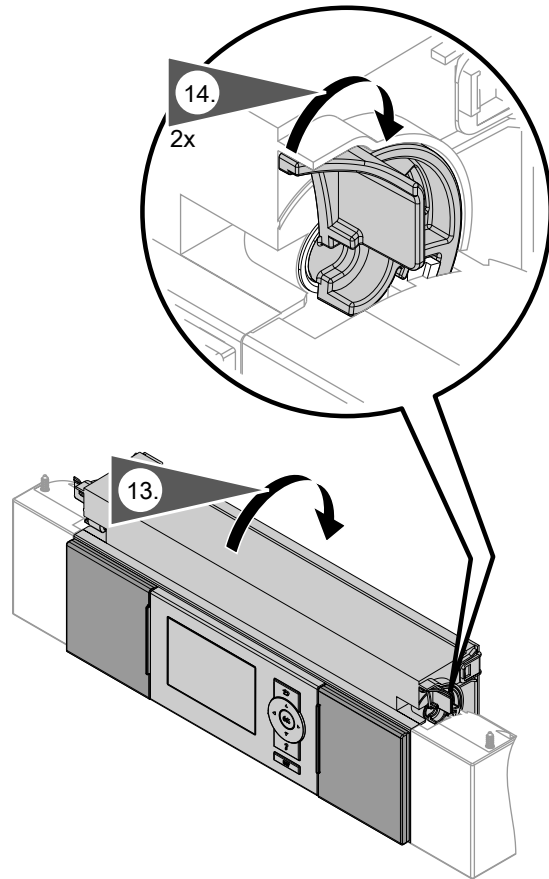

Fig. 23

Electrical connection (cont.)

Overview of electrical connections

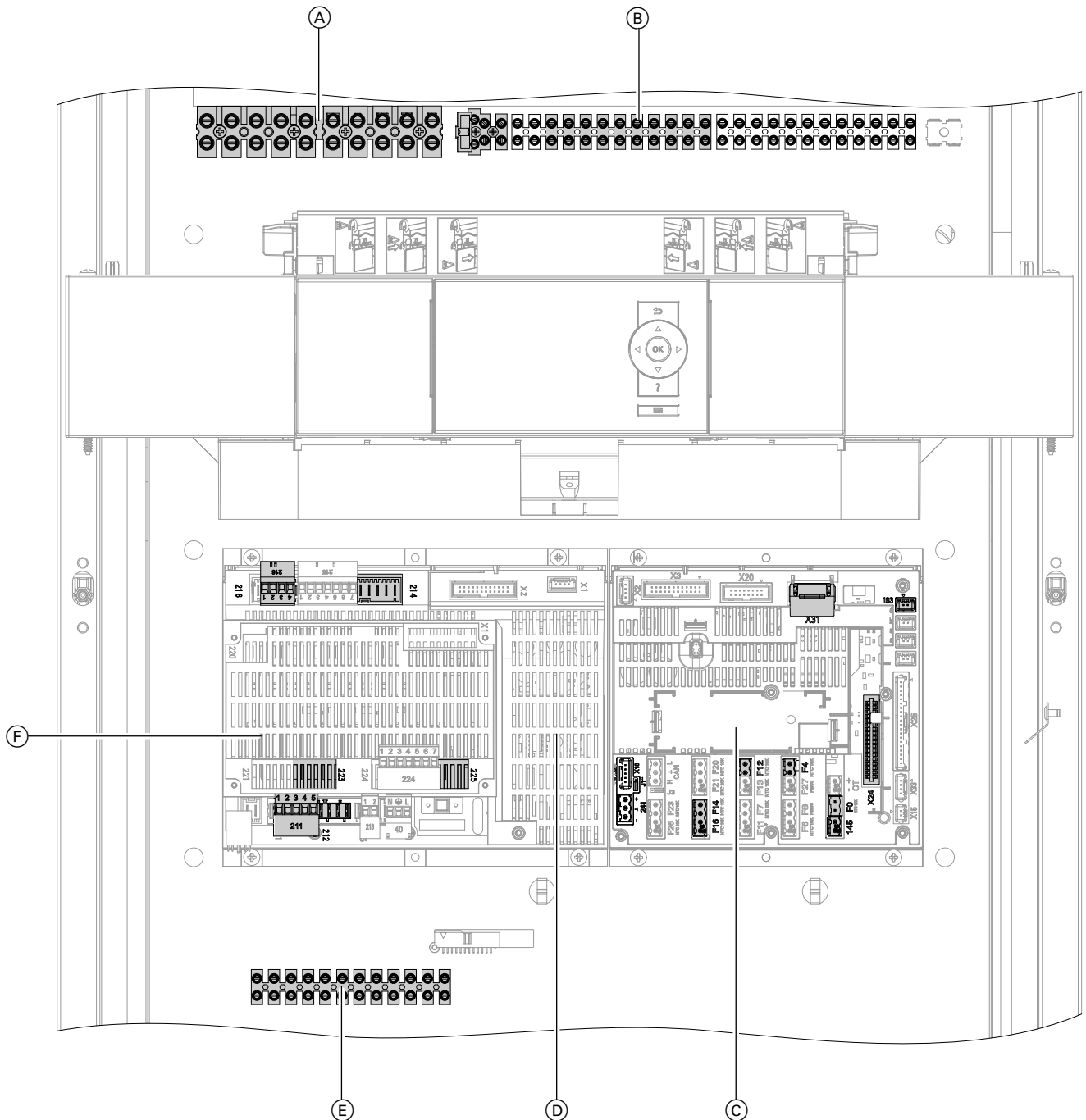

Fig. 24

- (A) Mains terminals for compressor and instantaneous heating water heater: See page 39.
- (B) Luster terminals (mains terminals for heat pump control unit, signal and safety connections): See page 32.
 F1 Fuse 6.3 A (slow)
 X1 Terminals for earth conductors of **all** associated system components
 X2 Terminals for neutral conductors of **all** associated system components
- (C) Controller and sensor PCB (low voltage connections): See page 34.
- (D) Main PCB (230 V~ components): See page 28.
 F3 Fuse 2.0 A H (slow)
- (E) Luster terminals: Connections N and ⊕
- (F) Expansion PCB on main PCB (230 V~ components): See page 31.

Electrical connection (cont.)

Main PCB (function components 230 V~)

Information regarding the connection values

- The specified output is the recommended connected load.
- Total output of all components connected directly to the heat pump control unit (e.g. pumps, valves, message facilities, contactors): **Max. 1000 W**
If the total output is < 1000 W, the individual rating of a component (e.g. pump, valve, message facility, contactor) can be greater than specified. However, the breaking capacity of the relevant relay must not be exceeded.
- The specified current indicates the max. switching current of the switching contact. Observe total current of 5 A.

Set the required parameters during commissioning:
See page 54 onwards.

Plug 211



Terminals	Function	Explanation
211.1 	Well pump and/or Additional primary pump to increase residual head <ul style="list-style-type: none"> ▪ Installation outside the heat pump in the primary circuit flow ▪ No switching via PWM signal from the heat pump control unit Note <ul style="list-style-type: none"> ▪ The factory-fitted primary pump is connected to the EEV PCB: See chapter "Overview of electrical components". ▪ The factory-fitted primary pump must be operated at a constant 100 % speed ("Start output primary source (htg) 7442" at "100"). 	Supply values <ul style="list-style-type: none"> ▪ Output: 200 W ▪ Voltage: 230 V~ ▪ Max. switching current: 4(2) A

Electrical connection (cont.)

Plug 211





Terminals	Function	Explanation
211.2 	<p>Additional secondary pump to increase residual head</p> <ul style="list-style-type: none"> Installation outside the heat pump in the secondary circuit flow No switching via PWM signal from the heat pump control unit <p>Note</p> <ul style="list-style-type: none"> The factory-fitted secondary pump is connected to the EEV PCB: See chapter "Overview of electrical components". The factory-fitted secondary pump must be operated at a constant 100 % speed ("Rated output secondary pump (PWM) 7343" at "100"). 	<ul style="list-style-type: none"> In systems without a buffer cylinder, no other heating circuit pump is required: See connection 212.2. Connect a temperature limiter in series to restrict the maximum temperature of underfloor heating circuit (if installed). <p>Supply values</p> <ul style="list-style-type: none"> Output: 140 W Voltage: 230 V~ Max. switching current: 4(2) A
211.5 ⚡ NC	Cooling control via NC-Box NC function (natural cooling)	<p>Connection values</p> <ul style="list-style-type: none"> Output: 10 W Voltage: 230 V~ Max. switching current: 4(2) A

Plug 212





Terminals	Function	Explanation
212.2 	Heating circuit pump for heating circuit without mixer A1/HC1	<ul style="list-style-type: none"> This pump is connected in addition to the secondary pump if a heating water buffer cylinder is installed. Connect a temperature limiter in series to restrict the maximum temperature of underfloor heating circuit (if installed). <p>Note</p> <p><i>In systems without heating water buffer cylinder the temperature limiter is connected to X3.2/X3.14 at the luster terminals: See chapter "Temperature limiter to restrict the maximum temperature of underfloor heating circuit".</i></p> <p>Connection values</p> <ul style="list-style-type: none"> Output: 100 W Voltage: 230 V~ Max. switching current: 4(2) A
212.3 	DHW circulation pump	<p>Connection values</p> <ul style="list-style-type: none"> Output: 50 W Voltage: 230 V~ Max. switching current: 4(2) A

Electrical connection (cont.)

Plug 214

Terminals	Function	Explanation
214.1  M2	External hook-up, heating/cooling circuits: Central heating demand, heating circuit M2/HC2	230 V~ digital input: <ul style="list-style-type: none"> 230 V~: Central heating demand for heating circuit M2/HC2 active 0 V: No demand Breaking capacity 230 V, 0.15 A
214.2  M2	External hook-up, heating/cooling circuits: Central cooling demand, heating circuit M2/HC2	230 V~ digital input: <ul style="list-style-type: none"> 230 V~: Room cooling demand for heating circuit M2/HC2 active 0 V: No demand Breaking capacity 230 V, 0.15 A
214.3  M3	External hook-up, heating/cooling circuits: Central heating demand, heating circuit M3/HC3	230 V~ digital input: <ul style="list-style-type: none"> 230 V~: Room heating demand for heating circuit M3/HC3 active 0 V: No demand Breaking capacity 230 V, 0.15 A
214.4  M3	External hook-up, heating/cooling circuits: Central cooling demand, heating circuit M3/HC3	230 V~ digital input: <ul style="list-style-type: none"> 230 V~: Room cooling demand for heating circuit M3/HC3 active 0 V: No demand Breaking capacity 230 V, 0.15 A

Plug 216

Terminals	Function	Explanation
216.1  A1 	External hook-up, heating/cooling circuits: Central heating demand, heating circuit A1/HC1 Or Smart Grid: Floating contact 1	230 V~ digital input: <ul style="list-style-type: none"> 230 V~: Central heating demand for heating circuit A1/HC1 active 0 V: No demand Breaking capacity 230 V, 2 mA 230 V~ digital input: <ul style="list-style-type: none"> 230 V~: Contact active 0 V: Contact not active Breaking capacity 230 V, 2 mA
216.2  A1	External hook-up, heating/cooling circuits: Room cooling demand, heating circuit A1/HC1	230 V~ digital input: <ul style="list-style-type: none"> 230 V~: Room cooling demand for heating circuit A1/HC1 active 0 V: No demand Breaking capacity 230 V, 0.15 A
216.4 	Smart Grid: Floating contact 2	230 V~ digital input: <ul style="list-style-type: none"> 230 V~: Contact active 0 V: Contact not active Breaking capacity 230 V, 2 mA

Note

If external hook-up for heating/cooling circuits is connected and selected, Smart Grid can be connected to the EA1 extension (accessories) ("**Enable Smart Grid 7E80**" on "1").

Electrical connection (cont.)

Expansion PCB on main PCB (230 V~ components)

Information regarding the connection values

- The specified output is the recommended connected load.
- Total output of all components connected directly to the heat pump control unit (e.g. pumps, valves, message facilities, contactors): **Max. 1000 W**
If the total output is < 1000 W, the individual rating of a component (e.g. pump, valve, message facility, contactor) can be greater than specified. However, the breaking capacity of the relevant relay must not be exceeded.
- The specified current indicates the max. switching current of the switching contact. Observe total current of 5 A.

Set the required parameters during commissioning:
See page 54 onwards.

Plug 223

Terminals	Function	Explanation
223.1 223.2 	Central fault message	Floating contact: <ul style="list-style-type: none"> ▪ Closed: Fault ▪ Open: No fault ▪ Not suitable for safety LV Connection values (contact rating): <ul style="list-style-type: none"> ▪ Voltage: 230 V~ ▪ Max. switching current: 4(2) A

Central fault message

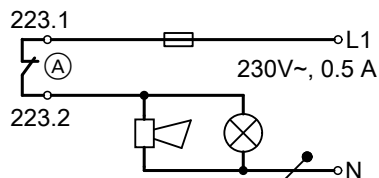

Fig. 25

(A) Terminals on extension PCB

Electrical connection (cont.)

Plug 225



Terminals	Function	Explanation
225.1 M2 III	Heating circuit pump of the heating circuit with mixer M2/HC2	<p>Connect a temperature limiter in series to restrict the maximum temperature of underfloor heating circuit (if installed).</p> <p>Note <i>In systems without heating water buffer cylinder the temperature limiter is connected to X3.2/X3.14 at the luster terminals: See chapter "Temperature limiter to restrict the maximum temperature of underfloor heating circuit".</i></p> <p>Connection values:</p> <ul style="list-style-type: none"> ▪ Output: 100 W ▪ Voltage: 230 V~ ▪ Max. switching current: 4(2) A
225.2 M2 X ▼ 🔒	Mixer motor control, heating circuit M2/HC2 Mixer CLOSE signal ▼	<p>Connection values:</p> <ul style="list-style-type: none"> ▪ Output: 10 W ▪ Voltage: 230 V~ ▪ Max. switching current: 0.2(0.1) A
225.3 M2 X ▲ 🔒	Mixer motor control, heating circuit M2/HC2 Mixer OPEN signal ▲	<p>Connection values:</p> <ul style="list-style-type: none"> ▪ Output: 10 W ▪ Voltage: 230 V~ ▪ Max. switching current: 0.2(0.1) A

Luster terminals (message and safety connections)



Set the required parameters during commissioning:
See page 54 onwards.

Terminals	Function	Explanation
F1	Fuse 6.3 A (slow)	Note <i>Observe the total load 1000 W of all connected components.</i>
X1	Earth conductor X1.⊕	Terminals for earth conductors of all associated system components
X2	Neutral conductor X2.N	Terminals for neutral conductors of all associated system components
X3.1	Switched phase	Via control unit ON/OFF switch Note <i>Observe the total load 1000 W of all connected components.</i>

Electrical connection (cont.)

Terminals	Function	Explanation
X3.2 X3.14 or at EA1 ex- tension 	<ul style="list-style-type: none"> In systems without heating water buffer cylinder: Temperature limiter to restrict the maximum temperature of underfloor heating circuit (if installed) and/or <ul style="list-style-type: none"> "External blocking" signal: External blocking of compressor and pumps, mixer in control mode or CLOSE <p>Note <i>In systems with heating water buffer cylinder the temperature limiter is connected in series to the relevant heating circuit pump: See chapter "Temperature limiter to restrict the maximum temperature of underfloor heating circuit".</i></p>	Floating contact (N/O contact) required: <ul style="list-style-type: none"> Closed: Blocking enabled Open: No blocking Breaking capacity 230 V~, 2 mA <p>Note</p> <ul style="list-style-type: none"> <i>The system may no longer be protected against frost</i> <i>These and further external functions (e.g. provision of external set values) can alternatively be connected via the external EA1 extension.</i> <p><i>See "EA1 extension" installation instructions</i></p>
X3.3 X3.4 	Flow switch, well circuit	Requires floating contact: <ul style="list-style-type: none"> Closed: Heat pump operational Open: Heat pump shut down Breaking capacity 230 V, 0.15 A <p>Note <i>No jumper should be installed if a flow switch is connected.</i></p>
X3.6 X3.7 	Power-OFF	Requires floating contact: <ul style="list-style-type: none"> Closed: Heat pump operational Open: Heat pump shut down Breaking capacity 230 V, 0.15 A <p>Note</p> <ul style="list-style-type: none"> <i>No parameters need to be set</i> <i>No jumper should be installed if a power-OFF contact is connected.</i> <i>The compressor is "forced" off as soon as the contact opens.</i> <i>The power-OFF signal switches off the supply voltage of the respective component (subject to the power supply utility).</i> <i>For the instantaneous heating water heater, the stages to be switched off can be selected (parameter "Output for instant. heating water heater at power-OFF 790A").</i> <i>The power supply for the heat pump control unit (3 x 1.5 mm²) and the cable for the power-OFF signal can be combined in a single 5-core cable.</i> <p>In connection with Smart Grid: <i>The power-OFF signal must not be connected. Jumper must be installed.</i></p>

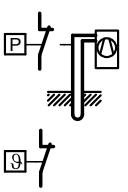
Electrical connection (cont.)





Terminals	Function	Explanation
X3.8 X3.9 	Pressure switch, primary circuit and/or Frost stat or Jumper	Requires floating contact: <ul style="list-style-type: none"> ▪ Closed: Safety chain has continuity ▪ Open: Safety chain interrupted; heat pump shut down ▪ Breaking capacity 230 V~, 0.15 A Connection: <ul style="list-style-type: none"> ▪ Connected in series if 2 safety components are installed ▪ Insert jumper if no safety components are installed.
X3.12 X3.13 or at external EA1 extension 	"External demand" signal: External starting of compressor and pumps; mixer in control mode or OPEN, changeover of the operating status of several system components	Requires floating contact: <ul style="list-style-type: none"> ▪ Closed: Demand ▪ Open: No demand ▪ Breaking capacity 230 V~, 2 mA <p>Note <i>These and further external functions (e.g. provision of external set values) can alternatively be connected via the external EA1 extension.</i> <i>See "EA1 extension" installation instructions</i></p>
X40	Heat pump control unit power supply: Phase L or L1 X40.⊕ Earth conductor terminal X40.N Neutral conductor terminal	Power supply 230 V~: See chapter "Power supply".

Controller and sensor PCB (low voltage connections)

Set the required parameters during commissioning:
See page 54 onwards.

Plug	Sensor/component	Type
F0	Outside temperature sensor	NTC 10 kΩ
F4	Buffer temperature sensor	NTC 10 kΩ
F12	Flow temperature sensor, heating circuit with mixer M2/HC2	NTC 10 kΩ
F14	Flow temperature sensor, cooling circuit: Heating circuit without mixer A1/HC1 or separate cooling circuit SKK	NTC 10 kΩ
F16	Room temperature sensor, cooling circuit <ul style="list-style-type: none"> ▪ Required for separate cooling circuit SKK ▪ Recommended for heating/cooling circuit without mixer A1/HC1 	NTC 10 kΩ
145	KM-BUS (wires interchangeable) Use the KM-BUS distributor (accessories) if several devices are connected. KM-BUS subscribers (examples): <ul style="list-style-type: none"> ▪ Mixer extension kit for heating circuit M3/HC3 ▪ Remote control (set heating circuit allocation on the remote control) ▪ EA1 extension, AM1 extension 	—
241	Modbus (do not interchange the wires), e.g. connection for energy meter of photovoltaic system	—

Electrical connection (cont.)

Plug	Sensor/component	Type
J1	Jumper for Modbus terminator  Terminator active (delivered condition)  Terminator not active	—
X18	Modbus (do not interchange the wires), e.g. Vitovent 300-F Note <i>If several appliances are to be connected, use the Modbus distributor (accessories): See "Modbus distributor" installation instructions.</i>	—
X24	Connection for LON communication module: See "LON communication module" installation instructions	—
X31	Coding card slot	—
 193  D	Connection, PWM signal, solar circuit pump	—

Note

Flow temperature sensor for heating circuit with mixer M3/HC3: The flow temperature sensor for one heating circuit with mixer M3/HC3 is connected to the mixer extension kit (accessories).

Connecting a temperature limiter to restrict the maximum temperature of underfloor heating circuit

System without heating water buffer cylinder: Connection to X3.2/X3.14

If the temperature limiter installed to restrict the maximum temperature of the underfloor heating circuit responds, the heat pump and the secondary pump are switched off. The underfloor heating circuit is no longer supplied.

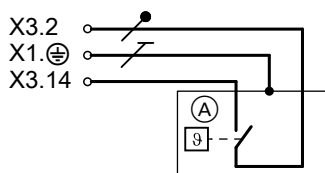

Fig. 26

(A) Temperature limiter to restrict the maximum temperature of underfloor heating systems

! **Please note**
 If the temperature limiter installed to restrict the maximum temperature of underfloor heating circuit is designed as an **N/C contact**, the heat pump will not start up.
 Design the temperature limiter to restrict the maximum temperature of underfloor heating circuit as **N/O contact**.

! **Please note**
 Incorrect parameter setting may result in the temperature limiter **not immediately** switching off the secondary pump after being triggered, but instead with a time delay.

Set "**Effect of external blocking on pumps/compressor 701A**" to "**16**" (select "**bit 5**").

! **Please note**
 The function of the temperature limiter can be disabled by other functions.

- External hook-up, heating/cooling circuits: External hook-up for heating/cooling circuits (e.g. in conjunction with a Smart Home system) must not be set: Do not set "**Remote control 2003, 3003, 4003**" to "**2**".
- Smart Grid: For Smart Grid, use the EA1 extension (accessories): Set "**Enable Smart Grid 7E80**" to "**1**".

**Converting temperature limiter part no. 7151728,
7151729 into a N/O contact**

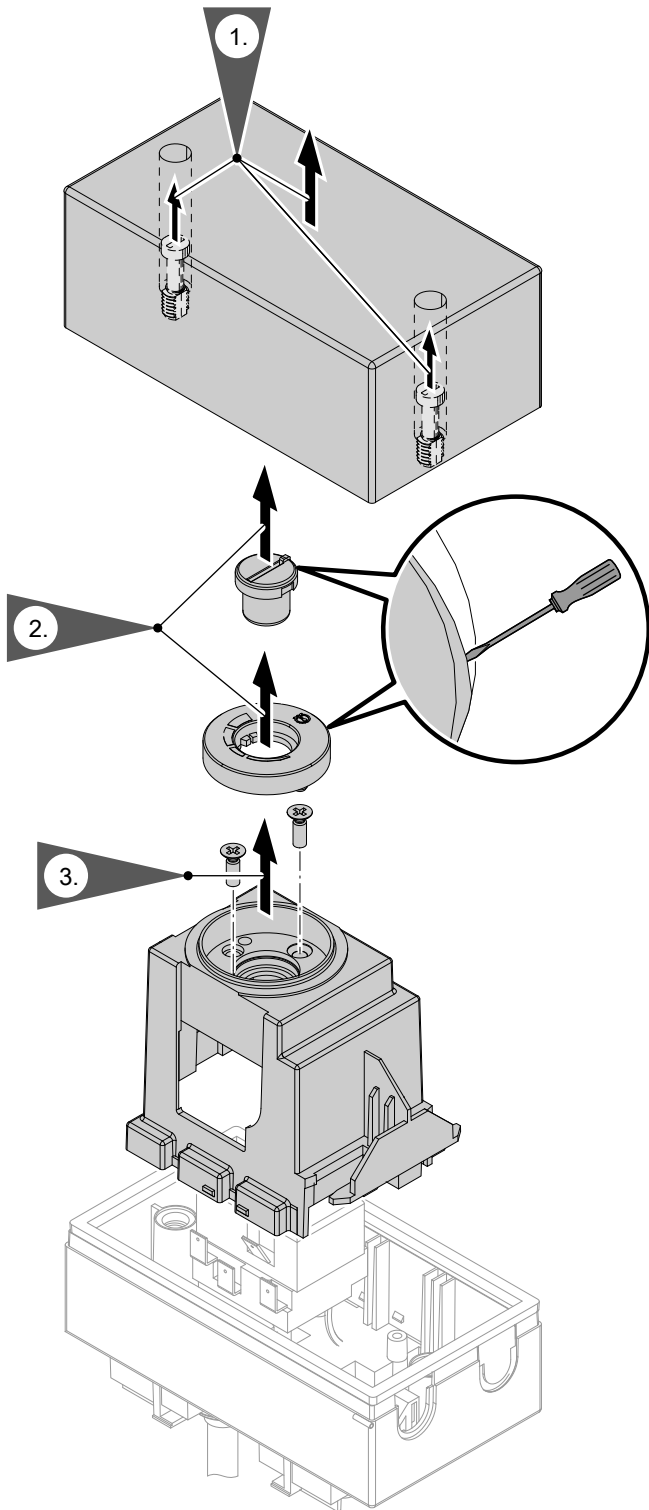

Fig. 27

Electrical connection (cont.)

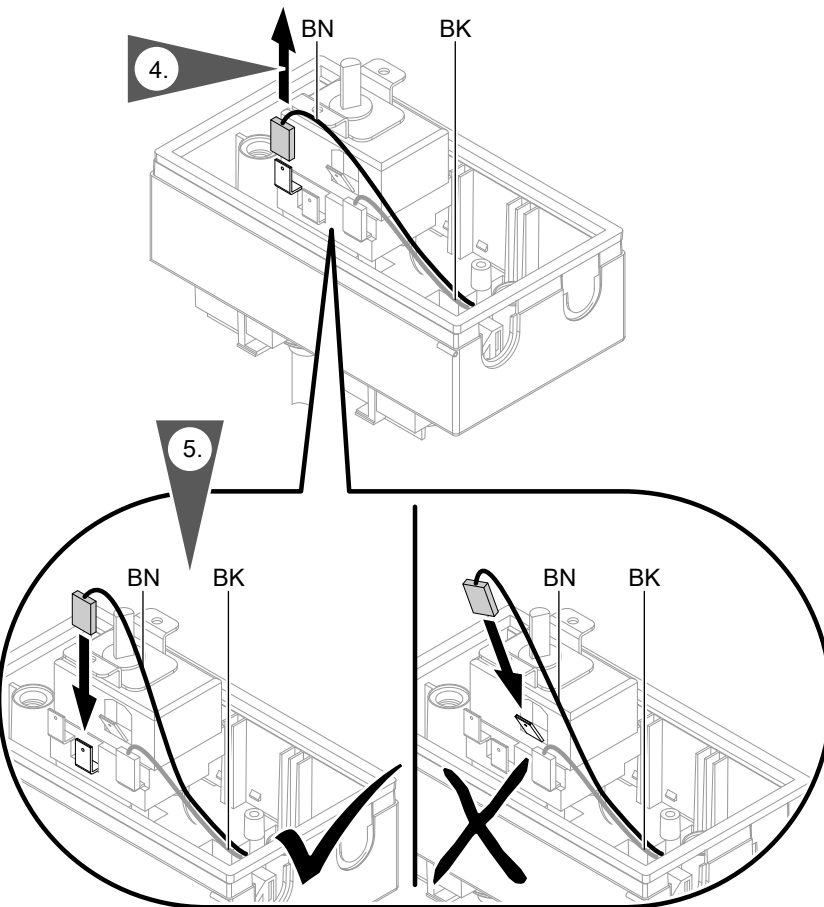

Fig. 28

Colour coding to IEC 60757:

- BN Brown
- BK Black
- GNYE Green/yellow

Assembling the temperature limiter: Steps 1 to 3 in reverse order

System with heating water buffer cylinder

If the temperature limiter installed to restrict the maximum temperature of underfloor heating circuit responds, the heating circuit pump of the relevant heating circuit is switched off. The heat pump remains on. The other heating circuits continue to be supplied.

! Please note
 If the temperature limiter installed to restrict the maximum temperature of underfloor heating circuit is designed as an **N/O contact**, the heating circuit pump will not start up. Design the temperature limiter for restricting the maximum temperature of underfloor heating circuit as **N/C contact**.

Heating circuit	Connection [Ⓐ]	Circulation pump [Ⓒ]	See Fig.
Without mixer A1/HC1	212.2 on main PCB	Heating circuit pump A1/HC1	29
With mixer M2/HC2	225.1 on expansion PCB	Heating circuit pump M2/HC2	30
With mixer M3/HC3	Plug ²⁰ at mixer extension kit	Heating circuit pump M3/HC3	31

General connection of a temperature limiter (B)

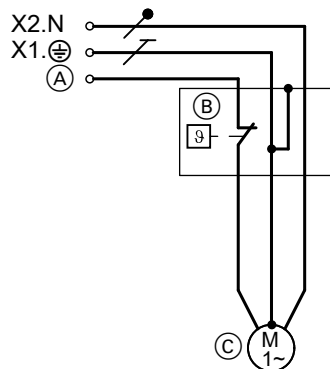

Fig. 29

- (A) Connection 212.2 on main PCB
Or
Connection 225.1 on expansion PCB
- (B) Temperature limiter to restrict the maximum temperature of underfloor heating circuit
- (C) Heating circuit pump A1/HC1 or M2/HC2

Connecting the temperature limiter, part no. 7151728, 7151729 (B)

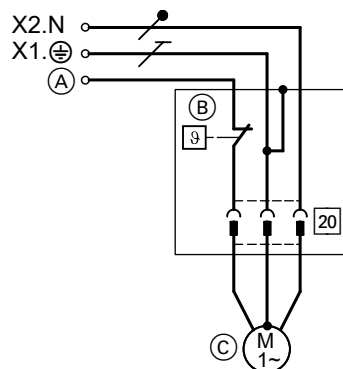

Fig. 30

- (A) Connection 212.2 on main PCB
Or
Connection 225.1 on expansion PCB
- (B) Temperature limiter to restrict the maximum temperature of underfloor heating circuit
- (C) Heating circuit pump A1/HC1 or M2/HC2

Connecting the temperature limiter, part no. 7151728, 7151729 (B) to the mixer extension kit

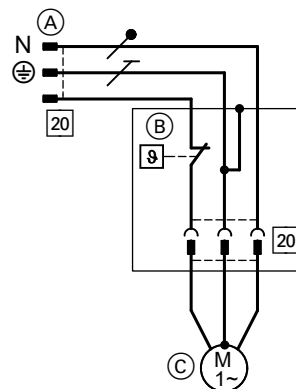

Fig. 31

- (A) Plug 20: Connect to extension kit.
- (B) Temperature limiter to restrict the maximum temperature of underfloor heating circuit
- (C) Heating circuit pump M3/HC3

Swimming pool heating

Note

- Swimming pool heating is controlled via EA1 extension with KM-BUS.
- Make connections to EA1 extension **only** in accordance with Fig. 32.
- A filter circuit pump **cannot** be controlled via the heat pump control unit.

Electrical connection (cont.)

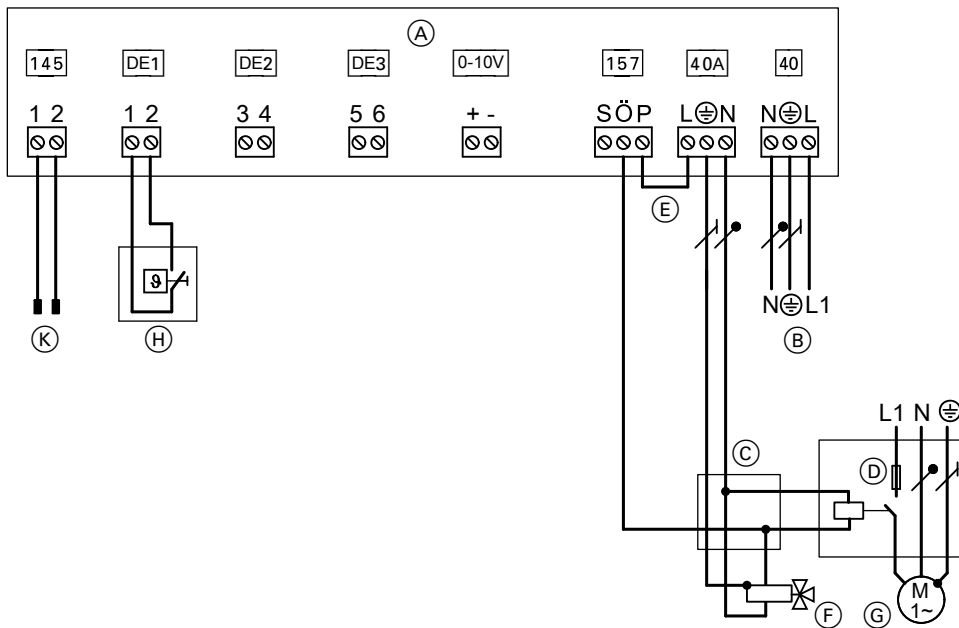



Fig. 32

- (A) EA1 extension
- (B) Power supply 1/N/PE 230 V/50 Hz
- (C) Junction box (on site)
- (D) Fuses and contactor for circulation pump for swimming pool heating (accessories)
- (E) Jumper
- (F) 3-way diverter valve for "Swimming pool" (zero volt: heating the heating water buffer cylinder)
- (G) Circulation pump for swimming pool heating (accessories)
- (H) Temperature controller for swimming pool temperature control (floating contact: 230 V~, 0.1 A, accessories)
- (K) KM-BUS connection to the controller and sensor PCB

Power supply

Isolators for non-earthed conductors

- Install an isolator in the power cable to provide omnipolar separation from the mains for all active conductors, corresponding to overvoltage category III (3 mm) for full isolation. This isolator must be fitted in the permanent electrical installation in line with installation requirements, e.g. mains isolator or upstream circuit breaker.
- We additionally recommend installing an AC/DC-sensitive RCD (RCD class B ) for DC (fault) currents that can occur with energy efficient equipment.
- Residual current devices to DIN VDE 0100-530 selecting and sizing.

 **Danger**
 Incorrect electrical installations can lead to serious injury from electrical current and result in appliance damage.

Connect the power supply and implement all safety measures (e.g. RCD circuit) in accordance with the following regulations:

- IEC 60364-4-41
- VDE regulations
- TAR low voltage VDE-AR-N-4100

 **Danger**
 The absence of system component earthing can lead to serious injury from electrical current and component damage in the event of an electrical fault.
 The appliance and pipework must be connected to the equipotential bonding of the building.

 **Danger**
 Incorrect core assignment can lead to serious injury from electrical current and result in appliance damage.
 Never interchange cores "L" and "N".

Power supply (cont.)

- In negotiations with your power supply utility, different supply tariffs for the main power circuits may be offered.
Observe the technical connection conditions of the power supply utility.
- If the compressor and/or instantaneous heating water heater are operated at an economy tariff (power-OFF), either provide an additional cable (e.g. $3 \times 1.5 \text{ mm}^2$) for the power-OFF signal from the distribution board (meter box) to the heat pump control unit.
or
Combine the cables for the power-OFF signal and for the heat pump control unit power supply ($3 \times 1.5 \text{ mm}^2$) in a 5-core cable.
- The assignment of the power-OFF (for compressor and/or instantaneous heating water heater) is made via the type of connection and by setting parameters in the heat pump control unit.
In Germany, the power supply can be cut for a maximum of 3×2 hours per day (24 h).
- The **heat pump control unit/PCB** must be supplied **without** power-OFF. Tariffs subject to possible shut-down must not be used here.
- When using power generated on site (use of power generated by the PV system to meet own requirements):
During the power-OFF period, it is **not** possible to operate the compressor utilising power generated on site.
- Protect the power cable to the heat pump control unit with an MCB/fuse of max. 16 A.
- For accessories and external components that will not be connected to the heat pump control unit, provide the power supply via the same MCB/fuse, or at least on the same phase, as the heat pump control unit.
Connection to the same MCB/fuse provides additional safety when the power is switched off.
Observe the power consumption of the connected consumers.
- If the mains connection is made with a flexible power cable, it must be ensured that the live conductors are pulled taut before the earth conductor in the event of strain relief failure. The length of the earth conductor wire will depend on the design.

Heat pump control unit power supply 230 V~

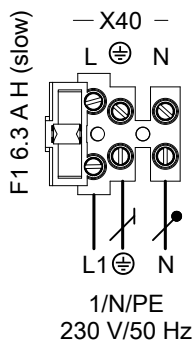

Fig. 33

Note

*This supply must **never** be blocked.*

- Max. fuse rating 16 A
- Standard tariff: No economy tariff with power-OFF possible for the heat pump control unit
- Recommended power cable:
 $3 \times 1.5 \text{ mm}^2$
- Recommended power cable with power-OFF for compressor/instantaneous heating water heater:
 $5 \times 1.5 \text{ mm}^2$

Compressor power supply 230 V~

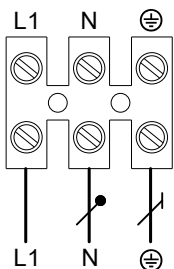

Fig. 34

- Economy tariff and power-OFF can be used
- No parameters need to be set when using economy tariff with power-OFF. The compressor is shut down during the power-OFF time.

Power supply (cont.)

Type	Cable	Max. cable length	Fuse protection
BWC-M	201.B06	3 x 2.5 mm ²	25 m / 16 A
	201.B08	3 x 2.5 mm ²	25 m / 20 A
	201.B10	3 x 2.5 mm ²	25 m / 25 A

Instantaneous heating water heater power supply 230 V~



Please note

Operating the instantaneous heating water heater without heating water damages the indirect coil.

Only connect the instantaneous heating water heater to the power supply after the heating system has been completely filled and vented.

- Economy tariff and power-OFF can be used
- No parameters need to be set when using economy tariff with power-OFF. The compressor is shut down during the power-OFF time.

Cable	Max. cable length	Fuse rating
7 x 2.5 mm ²	25 m	16 A

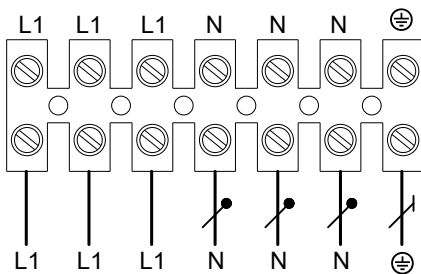

3/N/PE 230 V/50 Hz

Fig. 35

Power supply with power-OFF: Without on-site load disconnection

The power-OFF signal is connected directly to the heat pump control unit. The compressor is "forced" off when power-OFF is enabled.

Parameter "**Output for instant. heating water heater at power-OFF 790A**" determines whether and at what stage an instantaneous heating water heater remains operational during the power-OFF period.

Note

Observe the technical connection conditions of the relevant power supply utility.

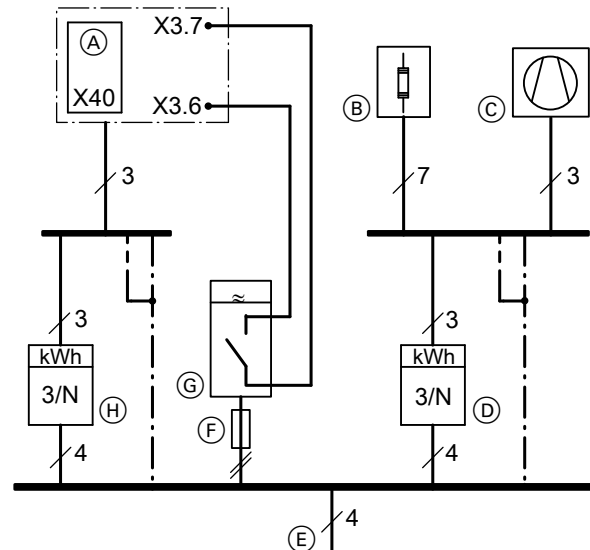

Fig. 36 Diagram excluding fuses and RCD

- (A) Heat pump control unit
- (B) Instantaneous heating water heater

Installation sequence

Power supply (cont.)

- Ⓒ Compressor
- Ⓓ Economy tariff meter
- Ⓔ Feed: TNC system
- Ⓕ Backup fuse, ripple control receiver
- Ⓖ Ripple control receiver (contact open: Power-OFF enabled)
- Ⓗ Premium tariff meter

Power supply with power-OFF: With on-site load disconnection

The power-OFF signal is connected to the on-site contactor of the economy tariff power supply and to the heat pump control unit. The compressor **and** instantaneous heating water heater are "forced" off when power-OFF is enabled.

Note

Observe the technical connection conditions of the relevant power supply utility.

- Ⓒ Compressor
- Ⓓ Economy tariff meter
- Ⓔ Feed: TNC system
- Ⓕ Backup fuse, ripple control receiver
- Ⓖ Ripple control receiver (contact open: Power-OFF enabled)
- Ⓗ Premium tariff meter
- Ⓚ Mains isolator

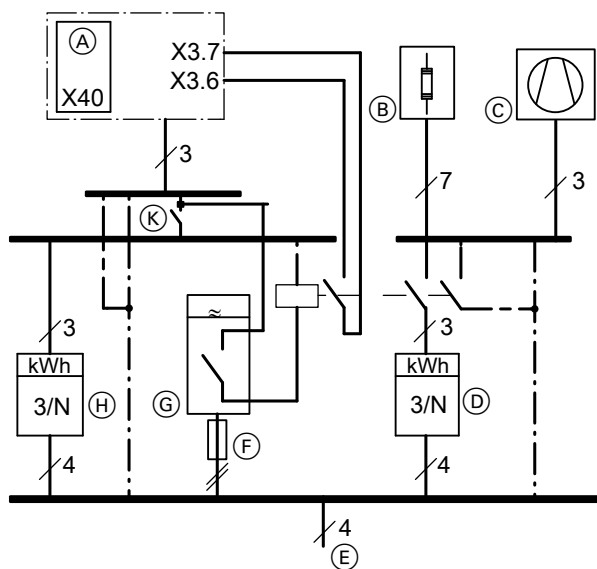

Fig. 37 Diagram excluding fuses and RCD

- Ⓐ Heat pump control unit
- Ⓑ Instantaneous heating water heater

Power supply (cont.)

Mains power supply in conjunction with self-consumption

Without power-OFF

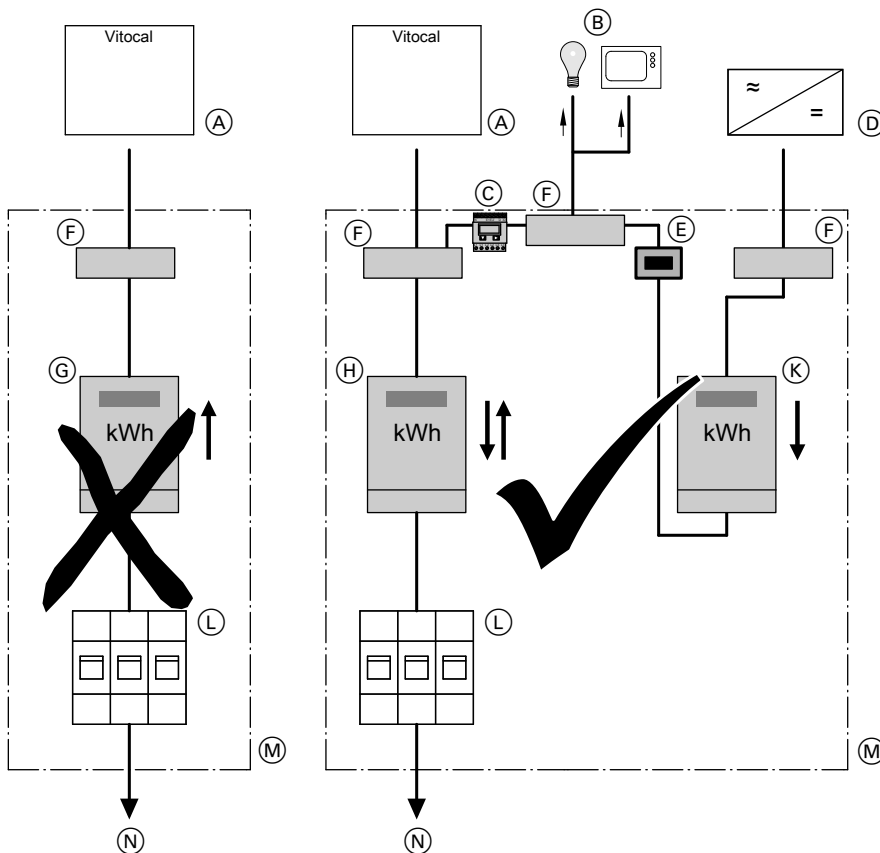

Fig. 38

- (A) Heat pump
- (B) Additional consumers (of self-generated power) in the household
- (C) Energy meter
- (D) Inverter
- (E) Isolator for the photovoltaic system
- (F) Terminal
- (G) Double-tariff meter (for special tariff for heat pumps)
Not permissible in conjunction with photovoltaic systems for self-consumption
- (H) Bidirectional meter (for photovoltaic systems suitable for self-consumption):
Energy drawn from power supply utility and energy exported to power supply utility
- (K) Meter with reversing block:
For energy generated by the photovoltaic system
- (L) Isolator for domestic power supply connection (distribution panel)
- (M) Distribution panel
- (N) Domestic distribution box

Smart Grid

The Smart Grid functions are switched via the two PSU floating contacts.

Connection options for the two floating contacts:

- To EA1 extension as shown in Fig. 39
- To the heat pump control unit as shown in Fig. 40

Power supply (cont.)

Connection to EA1 extension

Condition: "Enable Smart Grid 7E80" must be at "1".

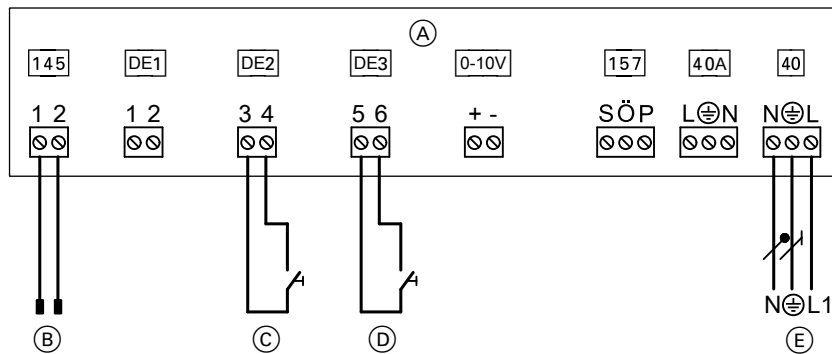

Fig. 39

- (A) EA1 extension
- (B) Connection to controller and sensor PCB
- (C) Floating N/O contact 1: The agreement of the power supply utility may be required

- (D) Floating N/O contact 2: The agreement of the power supply utility may be required
- (E) Power supply 1/N/PE 230 V/50 Hz

Note

- If Smart Grid is enabled ("Enable Smart Grid 7E80" set to "1"), both inputs DE2 and DE3 **cannot** be used for signals "External demand" or "External blocking".
- The power-OFF function is integral to Smart Grid. Therefore do **not** connect the power-OFF signal to terminals X3.6 and X3.7. Do **not** remove jumper.

Note

- If Smart Grid is connected to the two digital inputs on main PCB ("Enable Smart Grid 7E80" set to "4"), the external hook-up for the heating/cooling circuits must not be switched on ("Remote control 2003" set to "2"). Otherwise the Smart Grid will not be active.
- The power-OFF function is integral to Smart Grid. In this case, therefore, the power-OFF signal must **not** be connected to connections X3.6 and X3.7.

Connection to heat pump control unit

Condition: "Enable Smart Grid 7E80" must be at "4".

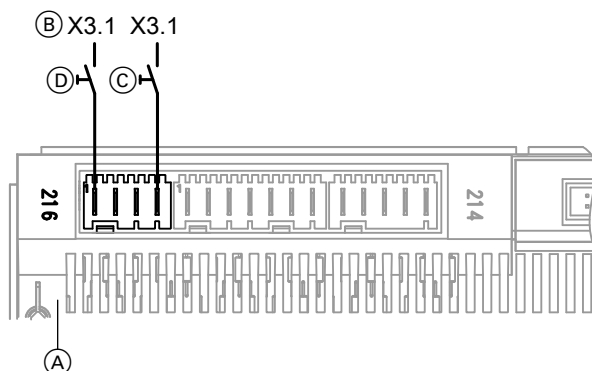

Fig. 40

- (A) Main PCB
- (B) Connection X3.1 (L') on the luster terminals
- (C) Floating contact 1: The agreement of the power supply utility may be required
- (D) Floating contact 2: The agreement of the power supply utility may be required

Make connections at terminals X3.8/X3.9

After connecting the power supply, one of the following components **must** be connected at terminals X3.8 and X3.9:

- Primary circuit pressure switch and/or frost stat
or
- jumper supplied

Closing the heat pump



Please note

Leaking hydraulic connections lead to appliance damage.

- Check for leaks in the internal and on-site hydraulic connections.
- In the event of leaks, switch off the appliance immediately. Drain liquid via the drain & fill valve. Check the seating of seal rings. **Always** replace displaced seal rings.



Please note

If the casing is not securely sealed, this can lead to damage from condensate, vibrations and excessive noise.

- Seal the casing door so it is soundproof and diffusion-proof.
- The outer panels must be fitted so as to be diffusion-proof during operation. Only remove the outer panels for maintenance and service work.



Danger

The absence of system component earthing can lead to serious injury from electrical current and component damage in the event of an electrical fault.

All earth conductor connections **must** be reconnected.

The appliance and pipework must be connected to the equipotential bonding of the building.

For assembly: See page 13.



Opening the heat pump



Danger

Contact with 'live' components can lead to serious injury from electric current.

- **Never touch** the wiring chambers (heat pump control unit and power supplies: See chapter "Overview of electrical components").
- When working on the appliance, isolate the system from the power supply, e.g. at a separate MCB/fuse or a mains isolator. Check the system is no longer 'live' and safeguard against reconnection.
- Prior to working on the appliance, wait at least 4 min until the voltage has completely dropped out.



Danger

The absence of system component earthing can lead to serious injury from electrical current and component damage in the event of an electrical fault.

All earth conductor connections **must** be reconnected.

The appliance and pipework must be connected to the equipotential bonding of the building.



Please note

Commissioning immediately after installation can lead to appliance damage.

Wait **at least 30 min** between installing and commissioning the appliance.



Please note

Refrigerant can escape when working on the refrigerant circuit.

Work on the refrigerant circuit must **only** be carried out by a certified contractor (in accordance with Regulations EU 517/2014 and EU 2015/2067).

1. Remove the front panels: See page 13.
2. When work is complete, close the heat pump: See page 45.



Commissioning the appliance

"Vitotronic 200" operating instructions



Writing reports

Enter the readings taken during commissioning into the reports from page 76 and the operator's log (if available).



Checking the refrigerant circuit for leaks



Danger

The refrigerant is a non-poisonous gas that displaces air. Unregulated escape of refrigerant in enclosed spaces can lead to breathing difficulties and suffocation.

- Ensure adequate ventilation in enclosed spaces.
- Always observe regulations and guidelines on handling this type of refrigerant.



Danger

Direct contact with refrigerant can be harmful to skin.

Wear safety goggles and protective gloves when working on the refrigerant circuit.



Please note

Refrigerant can escape when working on the refrigerant circuit.

Work on the refrigerant circuit must **only** be carried out by a certified contractor (in accordance with Regulations EU 517/2014 and EU 2015/2067).

Check the floor area, valves and all visible solder joints for traces of oil.

Note

Traces of oil indicate a leak in the refrigerant circuit. Have your heat pump checked over by a refrigeration engineer.

If there are any leaks, have the compact heat pump checked by a refrigeration engineer.

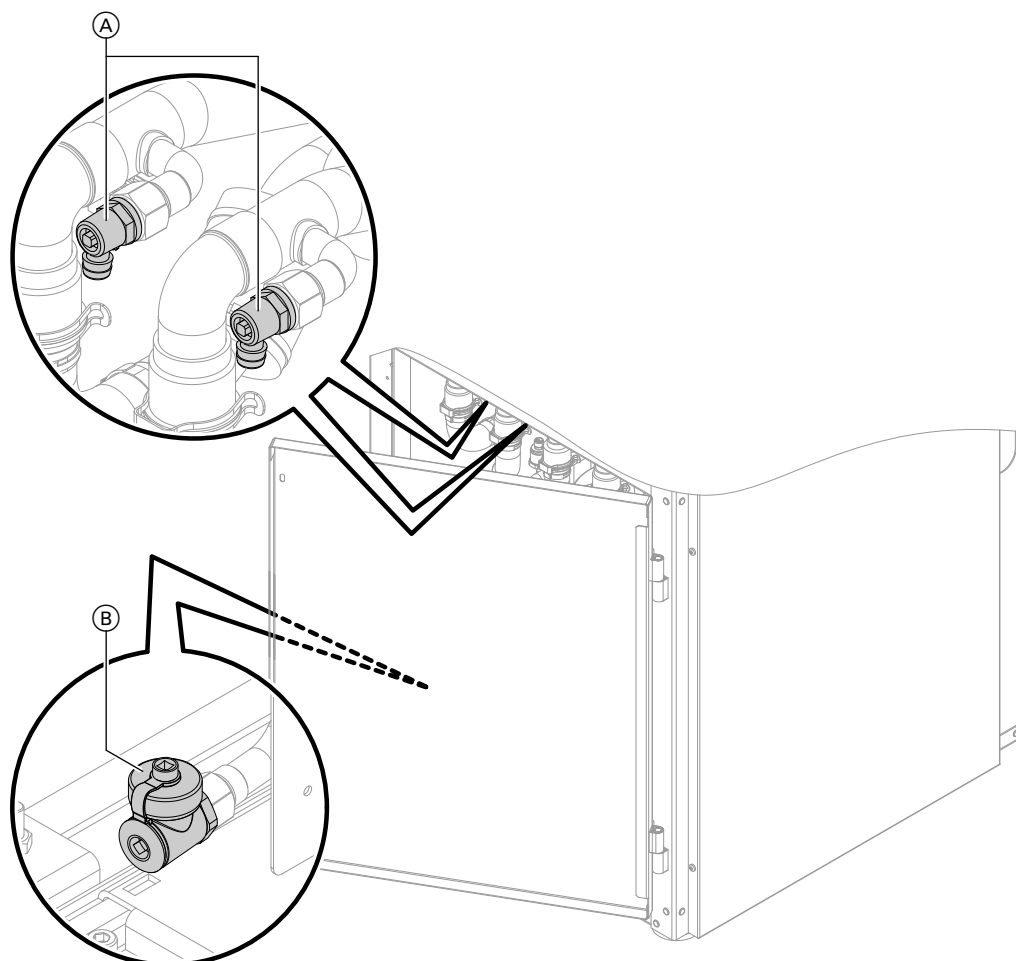

Fig. 41

- (A) Primary circuit air vent valves
- (B) Primary circuit drain & fill valve

! **Please note**
 Commissioning when the primary circuit is empty causes appliance damage. Charge and vent the primary circuit before connecting the power supply.

1. Check the pre-charge pressure of the expansion vessel.
2. Charge the primary circuit with Viessmann heat transfer medium and vent.

Note

Ensure frost protection down to at least $-15\text{ }^{\circ}\text{C}$. Viessmann heat transfer medium is a ready-mixed ethylene glycol-based medium. It contains inhibitors for corrosion protection. The heat transfer medium can be used at temperatures down to $-16\text{ }^{\circ}\text{C}$.

3. Check the connections for possible leaks. Replace faulty or displaced gaskets.

Information on setting the primary pump

Temperature differential between primary circuit flow and return: 3 K to 5 K.



Filling and venting the secondary side

Unsuitable fill and top-up water increases the level of deposits and corrosion. This can lead to system damage.

Hard water can also cause damage to the instantaneous heating water heater in particular.

Observe VDI 2035 regarding quality and amount of heating water, including fill and top-up water.

- Flush the heating system thoroughly before filling.
 - Only fill with water of potable quality.
 - Only fill and operate appliances that have an instantaneous heating water heater with softened water.
- For further information about fill and top-up water: See technical guide "Heat pump principles".

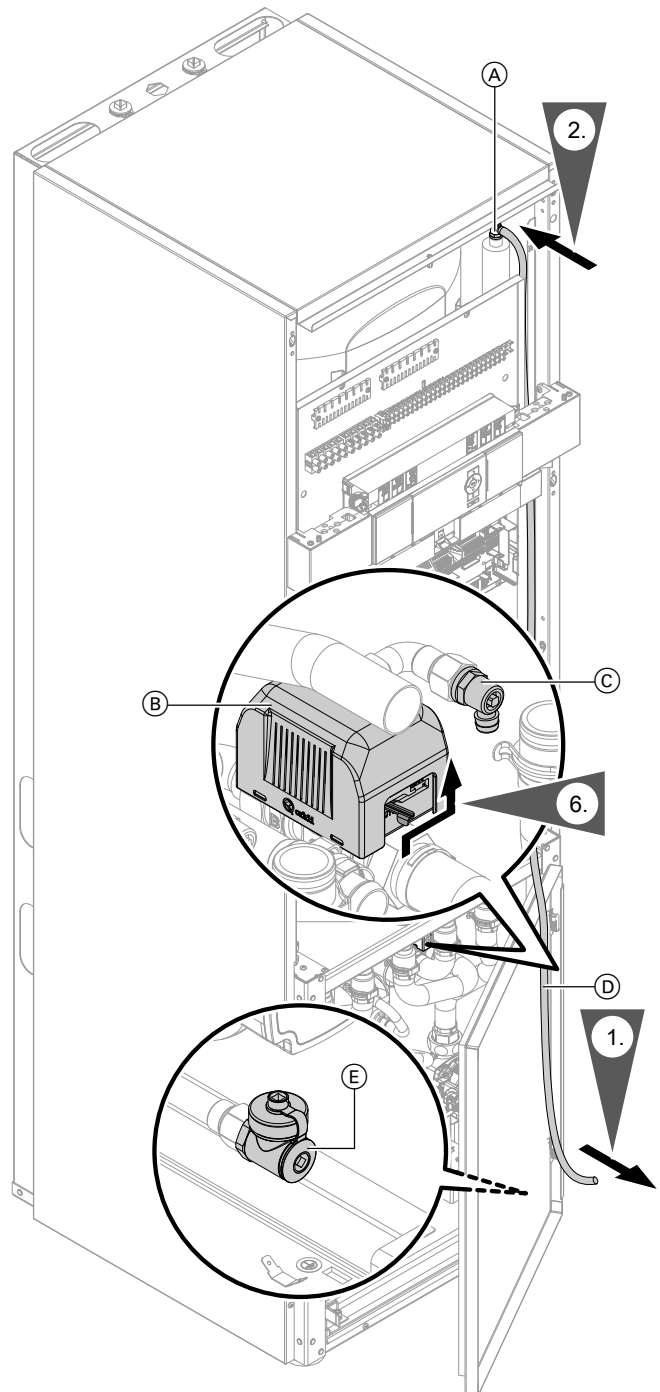

Fig. 42

- (A) Air vent valve, secondary circuit
- (B) 3-way diverter valve "central heating/DHW heating"
- (C) Air vent valve, secondary circuit
- (D) Hose
- (E) Drain & fill valve, secondary circuit

3. Open any non-return valves installed on site.
4. Check the pre-charge pressure of the expansion vessel: See page 50.
5. To fill (flush) and vent the secondary circuit, open the secondary circuit air vent valve.



Filling and venting the secondary side (cont.)

- To vent the indirect coil in the DHW cylinder, move the lever of 3-way diverter valve "Heating/DHW heating" into its centre position.
- Check the system pressure. Top up with water if required.
Minimum system pressure: 0.8 bar (80 kPa)
Permiss. operating pressure: 3 bar (0.3 MPa)



Please note

To prevent equipment damage, check the flow and return connections of the heat pump secondary circuit for **leaks**.

In the event of leaks, switch OFF the appliance immediately. Drain off the water. Check the seating of seal rings. Replace any seal rings that may have become dislodged.



Filling and venting the DHW cylinder on the DHW side

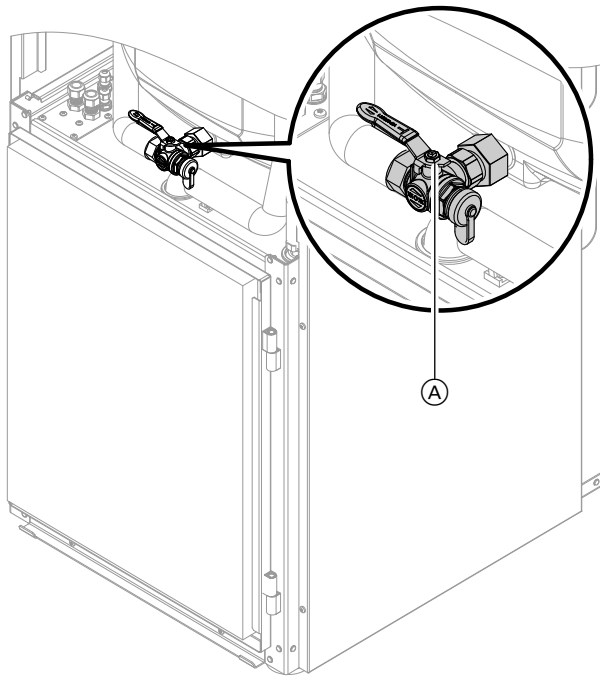

- Lever for valve (A) must be in the "left" position.
- Open the on-site DHW supply and a DHW draw-off point.
- Once air stops coming out of the DHW draw-off point, the DHW cylinder is completely filled.

Fig. 43



Checking the expansion vessel and heating circuit pressure



Observe engineering information.

Brine/water heat pump technical guide



Testing the anode connection

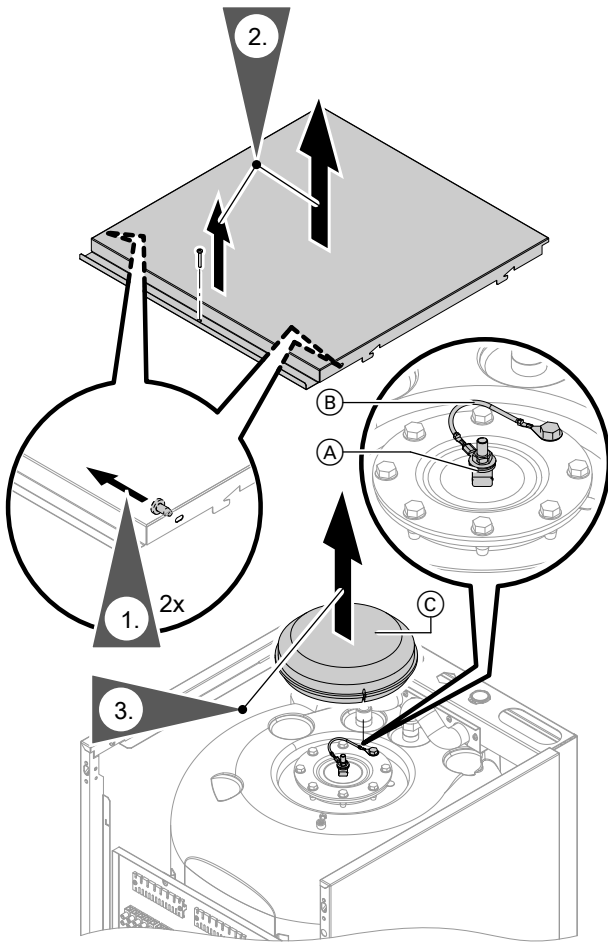

Fig. 44

3. Remove thermal insulation (C).
4. Check that earth cable (B) is connected to protective magnesium anode (A).
5. Insert thermal insulation (C).





Checking the anode earth current with an anode tester

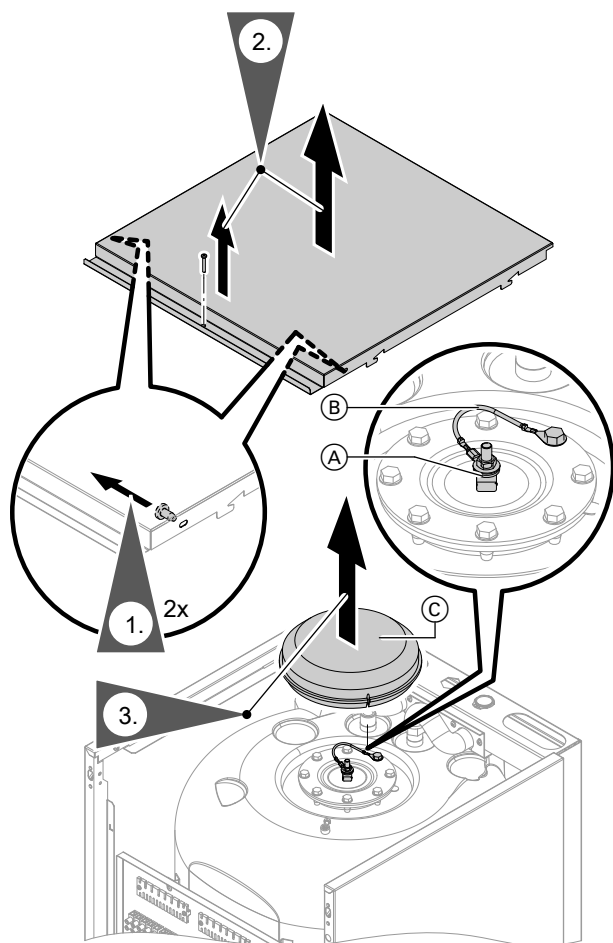

Fig. 45

3. Remove thermal insulation (C).
4. Remove earth cable (B) from protective magnesium anode (A).
5. Connect the tester (measuring range up to 5 mA) in series across tab (A) of protective magnesium anode and earth cable (B).

Anode earth current	Protective magnesium anode
> 0.3 mA	Function OK
< 0.3 mA	Visual inspection required: See chapter "Testing the protective magnesium anode".

6. Insert thermal insulation (C).



Checking the protective magnesium anode

We recommend replacing the protective magnesium anode once it has been reduced to a diameter of 10 to 15 mm.



Replacing the protective magnesium anode

Note

If the protective magnesium anode needs to be replaced, a maintenance-free impressed current anode (accessories) can be used.

For removal of the protective magnesium anode: See diagram in chapter "Cleaning the DHW cylinder".



Please note

A short circuit between the protective magnesium anode and the indirect coil negates the protective effect of the magnesium anode. This leads to corrosion damage on the DHW cylinder. Before connecting the electrical cables, check the resistance across terminals (A) and (B) (see diagram in chapter "Cleaning the DHW cylinder"). If the resistance is significantly less than infinity, check whether the protective magnesium anode is touching the indirect coil.



Draining the appliance on the DHW side

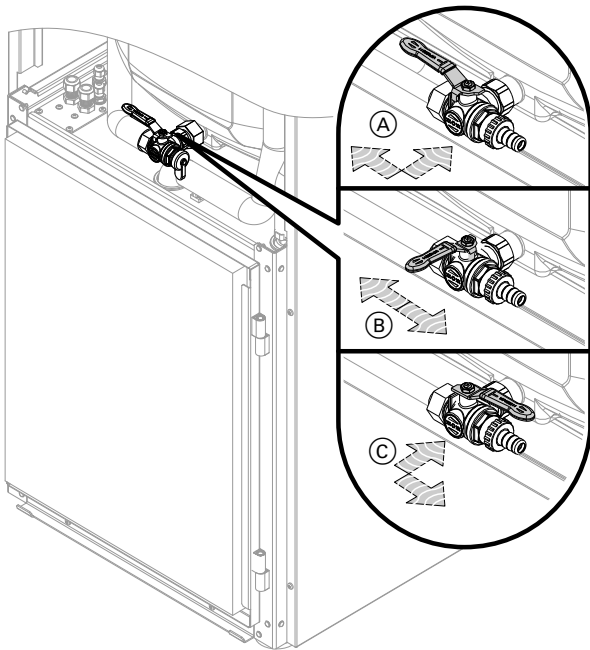

Fig. 46

- (A) Operation
- (B) Draining the drinking water circuit in the appliance **excluding** the DHW cylinder via the cold water connection
- (C) Draining the drinking water circuit in the appliance **including** the DHW cylinder via the DHW connection: The cold water connection remains filled.

1. Connect the hose to the drain & fill valve. Route the hose into a suitable container or drain outlet.

Note

Ensure adequate ventilation in the DHW pipework.

2. Turn drain & fill valve from lever position (A) to lever position (B) or (C) as required.



Cleaning the DHW cylinder

According to EN 806, a visual inspection and (if necessary) cleaning must be carried out no later than 2 years after commissioning, and as required thereafter.



Danger

The uncontrolled escape of DHW can cause scalding and building damage. Only open DHW and heating water connections with a depressurised DHW cylinder.



Please note

Negative pressure in the DHW cylinder can cause material damage. The air vent valve must always be open when draining the DHW cylinder with a suction pump.

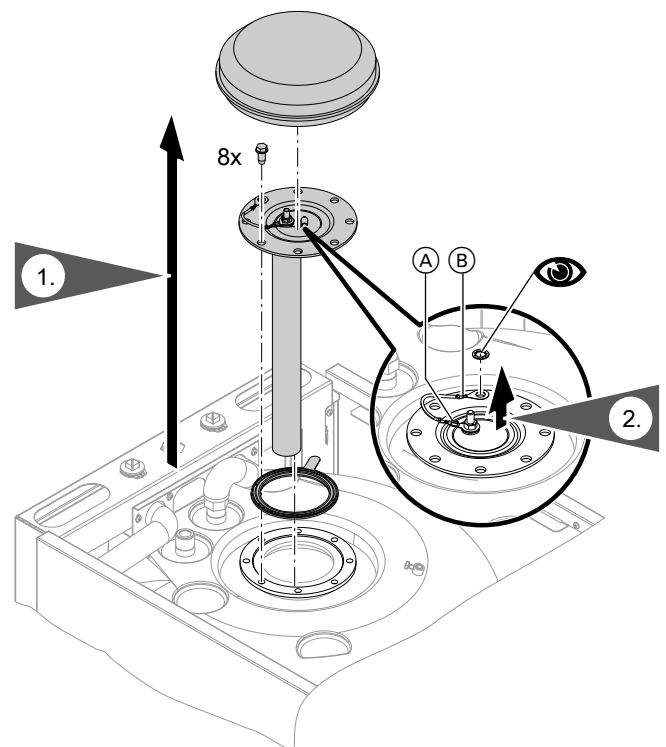

Fig. 47

Commissioning, inspection, maintenance



Cleaning the DHW cylinder (cont.)

3. To prevent contaminants entering the pipework, separate the DHW cylinder from the pipework.

4. Remove loose deposits with a pressure cleaner.



Please note

Pointed or sharp cleaning tools will damage the cylinder interior.
Only use plastic tools to clean the inside.

5. Use a chemical cleaning agent to remove hard deposits that cannot be removed with a pressure cleaner.



Please note

Cleaning agents containing hydrochloric acid will attack the DHW cylinder material.
Only use pH-neutral cleaning agents.



Danger

Cleaning agent residues can result in poisoning.
Fully drain all cleaning agent.
Always observe the information provided by the cleaning agent manufacturer.

6. Flush the DHW cylinder thoroughly after cleaning.

7. Fit the protective magnesium anode.



Please note

A short circuit between the protective magnesium anode and the indirect coil negates the protective effect of the magnesium anode. This leads to corrosion damage on the DHW cylinder.

Before connecting the electrical cables, check the resistance across terminals (A) and (B). If the resistance is significantly less than infinity, check whether the protective magnesium anode is touching the indirect coil.



Checking the electrical connections for firm seating



Danger

Contact with live components can lead to serious injury from electric current. Some components on PCBs remain live even after the power supply has been switched off.

- **Never touch** the wiring chambers (for heat pump control unit and power supply connections).
- When working on the appliance, isolate the system from the power supply, e.g. at a separate MCB/fuse or a mains isolator. Check the system is no longer live and safeguard against reconnection.
- Prior to working on the appliance, wait at least 4 min until the voltage has completely dropped out.



Switching on the main MCB/fuse



Commissioning the system

Commissioning (configuration, parameter settings and function check) can be carried out with or without the commissioning wizard (see following chapter and service instructions for the heat pump control unit).

Note

The type and extent of the parameters depend on the appliance type, on the selected system scheme and the accessories employed.



Commissioning the system (cont.)

- ! Please note**
 Air bubbles in the secondary circuit can destroy the instantaneous heating water heater. Completely fill and vent the heating system before commissioning the heat pump.

Commissioning with the commissioning assistant

The commissioning assistant automatically guides you through all the menus where settings have to be made. For this, "Coding level 1" is automatically active.

- ! Please note**
 Incorrect operation at "Coding level 1" may result in damage to the appliance and the heating system. Observe the service instructions for the "Vitotronic 200", otherwise the appliance warranty will be void.

Switch ON the ON/OFF switch on the control unit.

- The prompt "**Start commissioning?**" appears **automatically** on commissioning.

Note

The commissioning assistant can also be started manually:

To do this, press and hold  when switching on the control unit (progress bar visible).

- When the unit is first commissioned, the display is in German.



Fig. 48

- Manually switching some appliance components during commissioning enables the control unit to display messages. These messages are not appliance faults.

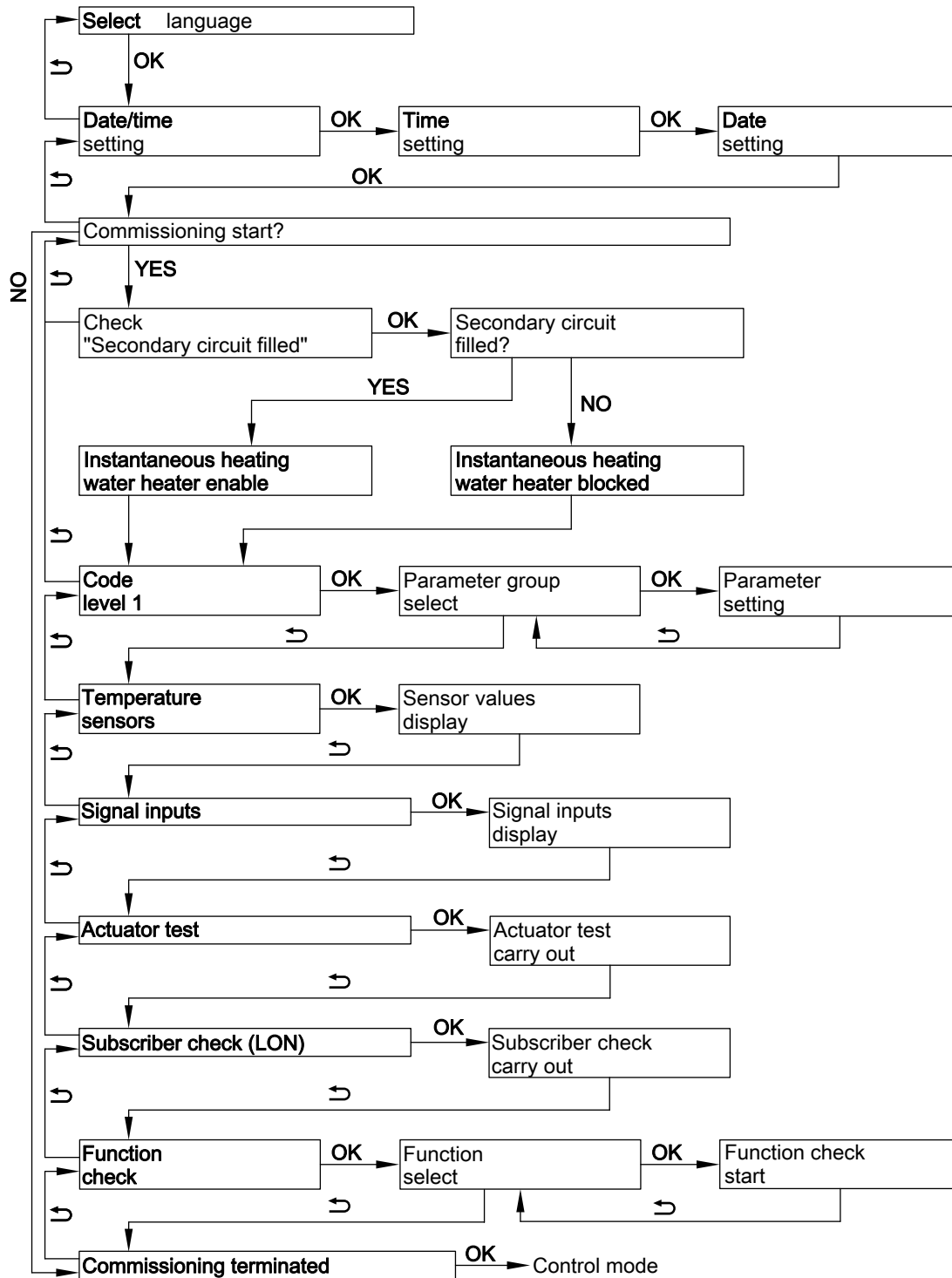

Fig. 49

Commissioning without the commissioning assistant

Activating the service menu

The service menu can be activated from any other menu.
Press and hold **OK** + **≡** simultaneously for approx. 4 s.

Deactivating the service menu

The service menu remains active until it is disabled with "**Terminate service?**", or if no key is pressed for 30 min.



Commissioning the system (cont.)

Setting parameters using "System scheme 7000" as an example

To set a parameter, first select the parameter group and then the parameter.

Service menu:

1. Press and hold **OK** + simultaneously for approx. 4 s.
2. Select **"Coding level 1"**.
3. Select parameter group: **"System definition"**
4. Select parameter: **"System scheme 7000"**
5. Set a system scheme: e.g. **"6"**

Alternatively, if the service menu was already active:

Extended menu:

- 1.
2. **"Service"**
3. Select **"Coding level 1"**.
4. Select parameter group: **"System definition"**
5. Select parameter: **"System scheme 7000"**
6. Set a system scheme: e.g. **"6"**

Required parameters for components connected on site

Parameters may need to be set subject to the appliance type, the selected system scheme and the accessories used.

Overview of required parameters: See the following chapter.

Detailed explanations of parameters
"Vitotronic 200" service instructions

System scheme

Overview of all available system schemes

Component	System scheme											
	0	1	2	3	4	5	6	7	8	9	10	11
Heating circuit												
A1/HC1	—	X	X	—	—	X	X	—	—	X	X	—
M2/HC2	—	—	—	X	X	X	X	X	X	X	X	—
M3/HC3	—	—	—	—	—	—	—	X	X	X	X	—
DHW cylinder	X	—	X	—	X	—	X	—	X	—	X	—
Heating water buffer cylinder	—	○	○	X	X	X	X	X	X	X	X	—
Instantaneous heating water heater	○	○	○	○	○	○	○	○	○	○	○	○
Swimming pool	—	○	○	○	○	○	○	○	○	○	○	—
Cooling												
A1/HC1	—	○	○	—	—	○	○	—	—	○	○	—
M2/HC2	—	—	—	○	○	○	○	○	○	○	○	—
M3/HC3	—	—	—	—	—	—	—	○	○	○	○	—
Separate cooling circuit SKK	○	○	○	○	○	○	○	○	○	○	○	—
Vitofriocal ice store system	○	○	○	○	○	○	○	○	○	○	○	○
Energy meter	○	○	○	○	○	○	○	○	○	○	○	○
Ventilation unit	○	○	○	○	○	○	○	○	○	○	○	○

- X Component is selected.
○ Component may be added.

For detailed information on system examples: See www.viessmann-schemes.com.



Parameters for circulation pumps and other components

Heating circuit pump

Parameter	Setting
"System definition" →	
"System scheme 7000"	<ul style="list-style-type: none"> ▪ With heating circuit HC1 without mixer Or ▪ With heating circuit HC2 with mixer Or ▪ With heating circuit HC3 with mixer

DHW circulation pump

Parameter	Setting
Extended menu →	
"Time program DHW circulation"	Set a time program.

Mixer extension kit for heating circuit M3/HC3

Parameter	Setting
"System definition" →	
"System scheme 7000"	With heating circuit HC3 Note <i>Set rotary switch S1 in the extension kit to "2": See "Mixer extension kit" installation instructions.</i>

Remote control for heating/cooling circuit

Parameter	Setting
"Heating circuit 1"/"Heating circuit 2"/"Heating circuit 3" →	
"Remote control 2003" Or "Remote control 3003" Or "Remote control 4003"	"1" Note <i>To assign a heating circuit, set the code at the remote control: See "Vitotrol" installation instructions.</i>

External extension

Parameter	Setting
"System definition" →	
"External extension 7010"	"1" EA1 extension "2" AM1 extension "3" EA1 and AM1 extensions Note <i>For parameters for external functions, see the following table.</i>



Commissioning the system (cont.)

Parameters for external functions

External demand

Parameter	Setting
"Internal hydraulics" → if necessary	
"Flow temperature external demand 730C"	Set flow temperature for external demand

External starting of the compressor; mixer in control mode or OPEN

Parameter	Setting
"System definition" →	
"Effect of external demand on heat pump/heating circuits 7014"	"0" to "7" (Observe parameter "Flow temperature external demand 730C")

External changeover of the operating status of various system components

Parameter	Setting
"System definition" →	
"System components for external changeover 7011"	"0" to "127"
"Operating status for external changeover 7012"	"0" to "3"
"Duration of external changeover 7013"	"0" to "12"

External blocking of compressor and pumps

Parameter	Setting
"System definition" →	
"Effect of external blocking on pumps/compressor 701A"	"0" to "31"

External blocking of the compressor; mixer in control mode or CLOSED

Parameter	Setting
"System definition" →	
"Effect of ext. blocking on heat pump/heating circuits 7015"	"0" to "8"
"Effect of external blocking on pumps/compressor 701A"	"0" to "31"

External hook-up for heating/cooling circuits

Parameter	Setting
"Heating circuit 1"/"Heating circuit 2"/"Heating circuit 3" →	
"Remote control 2003" or "Remote control 3003" or "Remote control 4003"	"2"



Cooling function parameters

Parameter	Setting
"Cooling" →	
"Cooling function 7100"	"0" No cooling "1" Natural cooling with NC-Box without mixer (accessories) "2" Natural cooling with NC-Box with mixer (accessories) "3" Never adjust.
"Cooling circuit 7101"	"1" Heating circuit A1/HC1 "2" Heating circuit M2/HC2 "3" Heating circuit M3/HC3 "4" Separate cooling circuit SKK

Room temperature sensor for separate cooling circuit

Parameter	Setting
"Cooling" →	
"Ranking room temp sensor separate cooling circuit 7106"	"0" Connection F16 "1" Heating circuit A1/HC1 "2" Heating circuit M2/HC2 "3" Heating circuit M3/HC3 "4" Never adjust.

Parameters for solar DHW heating

Parameters in conjunction with solar control module type SM1	Setting
"Solar" →	
"Type solar control unit 7A00"	"3"
Parameter C0xx	See installation and service instructions for "Solar control module, type SM1".

Parameters for instantaneous heating water heater

Parameter	Setting
"Electr booster heater" →	
"Enable instantaneous heating water heater 7900"	"1"
"Output for instant. heating water heater at power-OFF 790A"	"1" 3 kW "2" 6 kW "3" 9 kW

**Please note**

After the value **"1"** has been set for **"Enable instantaneous heating water heater 7900"**, the prompt **"Secondary circuit filled?"** appears automatically. If this prompt is responded to with **"No"**, the instantaneous heating water heater will not be enabled. Set **"Enable instantaneous heating water heater 7900"** to **"2"**. Fill the secondary circuit. Confirm prompt **"Secondary circuit filled?"** with **"Yes"**.



Commissioning the system (cont.)

Enable instantaneous heating water heater for DHW heating

Parameter	Setting
"DHW" →	
"Enable electric heaters for DHW heating 6015"	"1"

Parameters for swimming pool water heating

Parameter	Setting
"System definition" →	
"External extension 7010"	"1" or "3"
"Swimming pool 7008"	"1"

Parameters for ice store system

Parameter	Setting
"System definition" →	
"Select primary source 7030"	"1"
"External extension 7010"	"2"

Parameter	Setting
"Solar" →	
"Type solar control unit 7A00"	"2"

Possibly set additional parameters.

Parameter	Setting
"System definition" →	
"Start hysteresis solar air absorber 7031"	"0" to "500" (\pm 0 to 50 K)
"Min. runtime to suppress summer mode 7035"	"0" to "1440" min
"Last calendar week for summer mode 7036"	Calendar week "1" to "53"

Parameters for ventilation with Vitovent 200-C

Parameter	Setting
"Ventilation" →	
"Vitovent enable 7D00"	"2" Vitovent 200-C



Further enabling for Vitovent 200-C if necessary

Parameter	Setting
"Ventilation" →	
"Enable preheater bank electric 7D01"	"0" Defrosting without preheating coil ("Strategy, passive frost protection 7D2C") "1" Frost protection with preheating coil; defrosting via bypass "2" Frost protection with preheating coil; comfort function
"Strategy, passive frost protection 7D2C"	"0" Fans OFF "1" Defrosting via bypass "2" Supply air fan OFF
"Type of heat exchanger 7D2E"	"0" Countercurrent heat exchanger "1" Enthalpy heat exchanger
"Installation position 7D2F"	"0" Ceiling mounting "1" Wall mounting
"Function, external 230 V input, ventilation 7D3A"	"1" External switch (bathroom switch) enabled

Adjust values for Vitovent 200-C if necessary

Parameter	Setting
"Ventilation" →	
"Set room temperature 7D08"	"100" to "300" (± 10 to 30 °C)
"Flow rate reduced ventilation 7D0A"	Subject to sizing Ventilation unit service instructions
"Flow rate nominal ventilation 7D0B"	
"Flow rate intensive ventilation 7D0C"	

Parameters for ventilation with Vitovent 200-W/300-C/300-W

Parameter	Setting
"Ventilation" →	
"Vitovent enable 7D00"	"3" Vitovent 200-W or Vitovent 300-C or Vitovent 300-W



Commissioning the system (cont.)

Adjust values for Vitovent 200-W/300-C/300-W if necessary

Parameter	Setting
"Ventilation" →	
"Set room temperature C108"	Max. 4 K higher or lower than "Standard room temperature 2000" (adjustment value: 1 ± 0.1 °C)
"Background ventilation C109"	Subject to sizing
"Reduced ventilation C10A"	 Ventilation unit service instructions
"Standard ventilation C10B"	
"Intensive ventilation C10C"	
"Background ventilation, second fan duct C189" (Vitovent 200-W only)	
"Reduced ventilation, second fan duct C18A" (Vitovent 200-W only)	
"Standard ventilation, second fan duct C18B" (Vitovent 200-W only)	
"Intensive ventilation, second fan duct C18C" (Vitovent 200-W only)	

Parameters for ventilation with Vitovent 300-F

Parameter	Setting
"Ventilation" →	
"Vitovent enable 7D00"	"1" Vitovent 300-F

Further enabling for Vitovent 300-F if necessary

Parameter	Setting
"Ventilation" →	
"Enable preheater bank electric 7D01"	"1"
"Enable reheater bank hydraulic 7D02"	"1"
"Enable humidity sensor 7D05"	"1"
"Enable CO2 sensor 7D06"	"1"
"Type of heat exchanger 7D2E"	"0" Countercurrent heat exchanger "1" Enthalpy heat exchanger

Adjust values for Vitovent 300-F if necessary

Parameter	Setting
"Ventilation" →	
"Set room temperature 7D08"	"100" to "300" (± 10 to 30 °C)
"Flow rate reduced ventilation 7D0A"	 Ventilation unit service instructions
"Flow rate nominal ventilation 7D0B"	
"Flow rate intensive ventilation 7D0C"	



Parameters for utilisation of power generated on site

Parameter	Setting
"Photovoltaics" →	
"Enable own energy consumption PV 7E00"	"1"
"Threshold for electrical power 7E04"	"0" to "300" ($\hat{=}$ 0 to 30 kW)

Enable required functions for utilisation of power generated on site

Parameter	Setting
"Photovoltaics" →	
"Enable own energy consumption for set DHW temperature 2 7E10"	"1"
"Enable own energy consumption for DHW heating 7E11"	"1"
"Enable own energy consumption for heating water buffer cyl. 7E12"	"1"
"Enable own energy consumption for heating 7E13"	"1"
"Enable own energy consumption for cooling 7E15"	"1"
"Enable own energy consumption for coolant buffer cylinder 7E16"	"1"

Specify the temperature differential to the selected set value for the chosen function

Parameter	Setting
"Photovoltaics" →	
"Raise set DHW cylinder temperature PV 7E21"	"0" to "500" ($\hat{=}$ 0 to 50 K)
"Raise set heating water buffer cylinder temp PV 7E22"	"0" to "400" ($\hat{=}$ 0 to 40 K)
"Raise set room temperature PV 7E23"	"0" to "100" ($\hat{=}$ 0 to 10 K)
"Reduce set room temperature PV 7E25"	"0" to "100" ($\hat{=}$ 0 to 10 K)
"Reduce set coolant buffer cylinder temperature PV 7E26"	"0" to "100" ($\hat{=}$ 0 to 10 K)

Parameters for Smart Grid

Parameter	Setting
"Smart Grid" →	
"Enable Smart Grid 7E80"	"1" Connection to EA1 extension "4" Connection to heat pump control unit
"Smart Grid Enable elec heat 7E82"	"1" Stage 1 "2" Stage 2 "3" Stage 3

Specify the temperature differential to the selected set value for the chosen function

Parameter	Setting
"Smart Grid" →	
"Smart Grid set value increase for DHW heating 7E91"	"0" to "500" ($\hat{=}$ 0 to 50 K)
"Smart Grid set value increase for htg wtr buff 7E92"	"0" to "400" ($\hat{=}$ 0 to 40 K)
"Smart Grid set value increase for centr htg 7E93"	"0" to "100" ($\hat{=}$ 0 to 10 K)
"Smart Grid set value decrease for room t cool 7E95"	"0" to "100" ($\hat{=}$ 0 to 10 K)



Checking the system function

Displaying the system overview

The system overview displays the status of the heat pump and system components as well as the temperatures.

Service menu:

1. Press **OK** + simultaneously and hold for approx. 4 s.

2. **"Diagnosis"**

3. **"System overview"**

4. to toggle between "System overview, generation side" and "System overview, consumption side"



"Vitotronic 200" service instructions

Carrying out a function check

The function test serves to check the proper functioning of the different system components.

Service menu:

1. Press **OK** + simultaneously and hold for approx. 4 s.

2. **"Service functions"**

3. **"Function check"**

4. Start the required function, e.g. **"DHW"**. Only those functions are shown that correspond to the actual system equipment level. During the function check, the system overview is displayed.

5. Terminate function with .



"Vitotronic 200" service instructions

Resetting the instantaneous heating water heater



Please note

If the heat pump is exposed to temperatures below -15 °C , e.g. during storage or transport, the high limit safety cut-out of the instantaneous heating water heater may respond.

Heat up the high limit safety cut-out to above 20 °C . Press the reset button of the high limit safety cut-out: See Fig. 66.

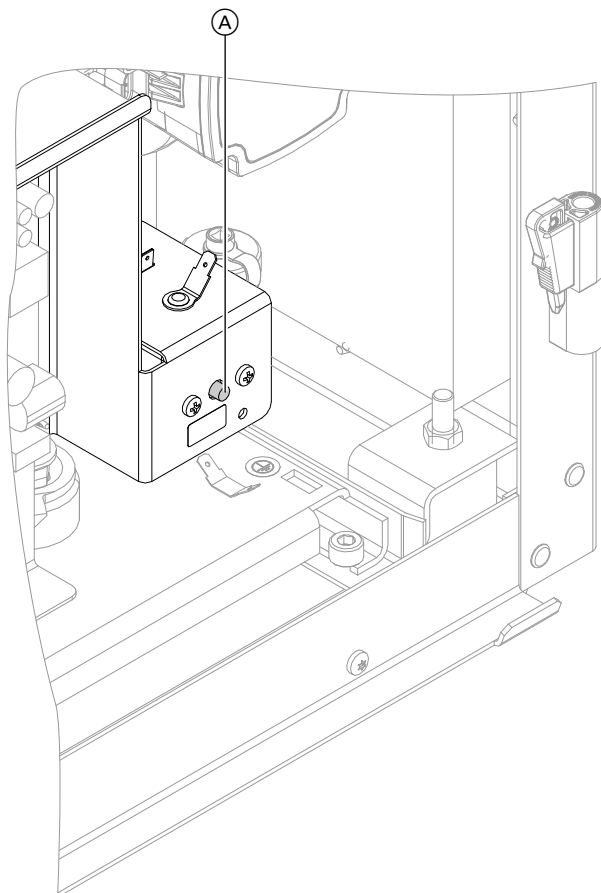

Fig. 50

Ⓐ Reset button

   **Closing the heat pump**

- !** **Please note**
Leaking hydraulic connections lead to appliance damage.
- Check for leaks in the internal and on-site hydraulic connections.
 - In the event of leaks, switch off the appliance immediately. Drain liquid via the drain & fill valve. Check the seating of seal rings. **Always** replace displaced seal rings.

- !** **Please note**
If the casing is not securely sealed, this can lead to damage from condensate, vibrations and excessive noise.
- Seal the casing door so it is soundproof and diffusion-proof.
 - The outer panels must be fitted so as to be diffusion-proof during operation. Only remove the outer panels for maintenance and service work.

- ⚠** **Danger**
The absence of system component earthing can lead to serious injury from electrical current and component damage in the event of an electrical fault.
All earth conductor connections **must** be reconnected.
The appliance and pipework must be connected to the equipotential bonding of the building.

1. Fit top panel: See page 52.
2. Fit front panels: See page 13.



Checking the heat pump for noise

Checking the appliance for unusual noises, e.g. operating noise of compressor and pumps. Venting again if required.



Instructing the system user

The system installer should hand the operating instructions to the system user and instruct the user in operating the system.

This includes all components installed as accessories, e.g. remote control units. In addition, the system installer must make the user aware of the required maintenance work.



Overview of electrical components

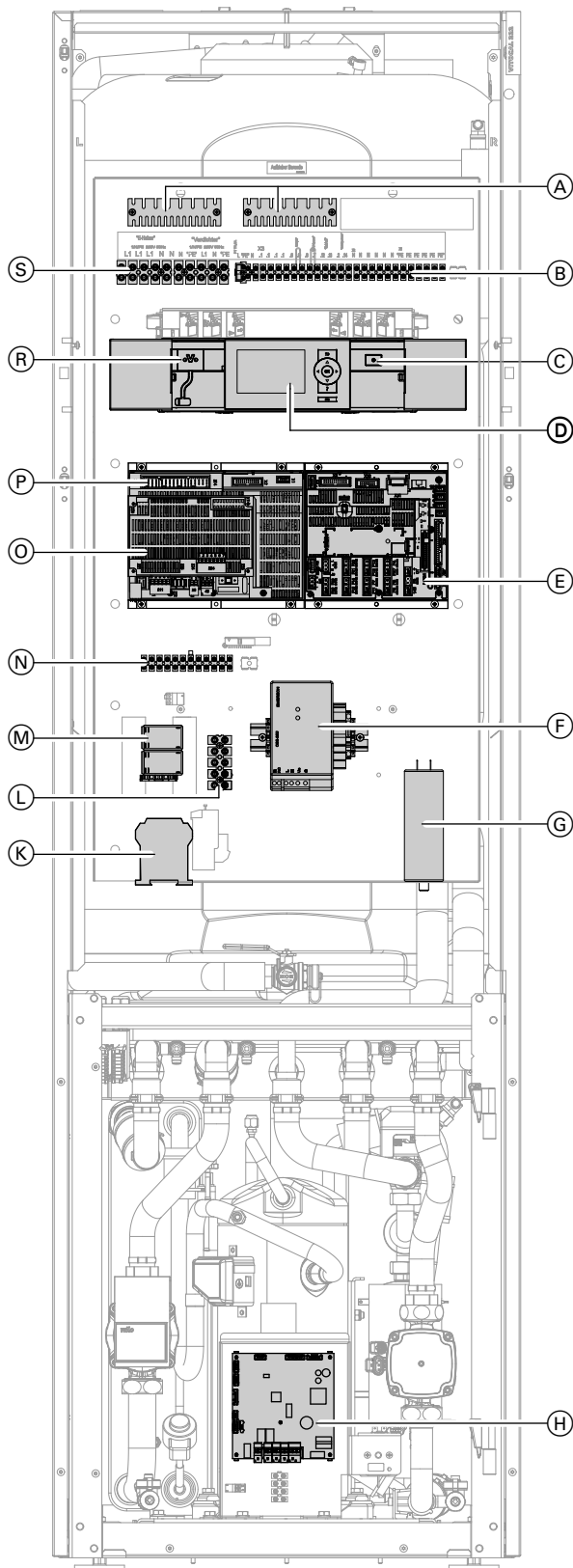

- (A) Strain relief fittings
- (B) Mains connection for heat pump control unit and luster terminals (signal and safety connections)
- (C) ON/OFF switch
- (D) Programming unit
- (E) Controller and sensor PCB (CU 401)
- (F) Full wave soft starter
- (G) Run capacitor 230 V~
- (H) EEV PCB (refrigerant circuit controller)
- (K) Contactor and thermal relay for compressor
- (L) Terminals for full wave soft starter
- (M) Switching module for instantaneous heating water heater
- (N) Luster terminals: Connections N and \ominus
- (O) Expansion PCB (SA 135) on main PCB
- (P) Main PCB (MB 761)
- (R) Viessmann Optolink interface
- (S) Mains terminals for compressor and instantaneous heating water heater

Fig. 51

Opening the programming unit

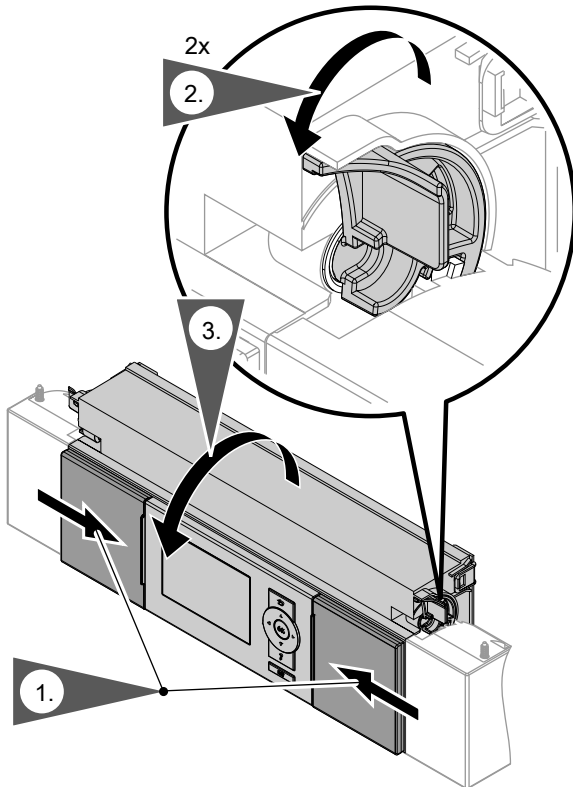

Fig. 52

Remove the cover from the programming unit if necessary

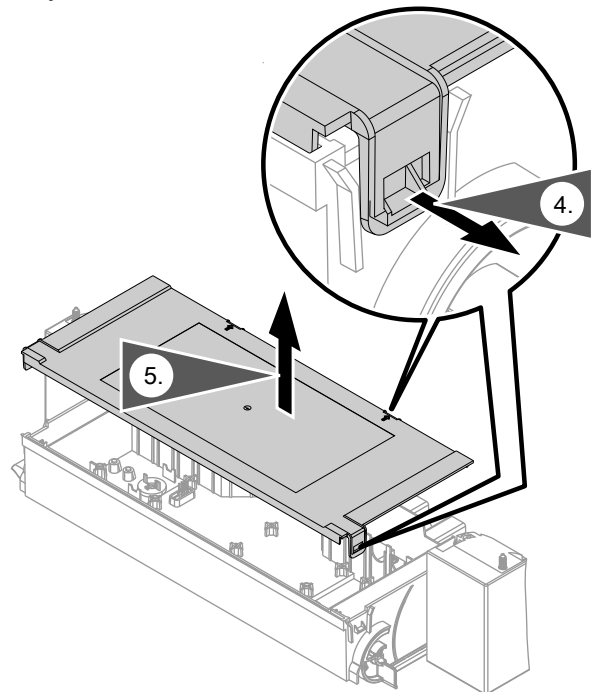

Fig. 53

Overview of internal components

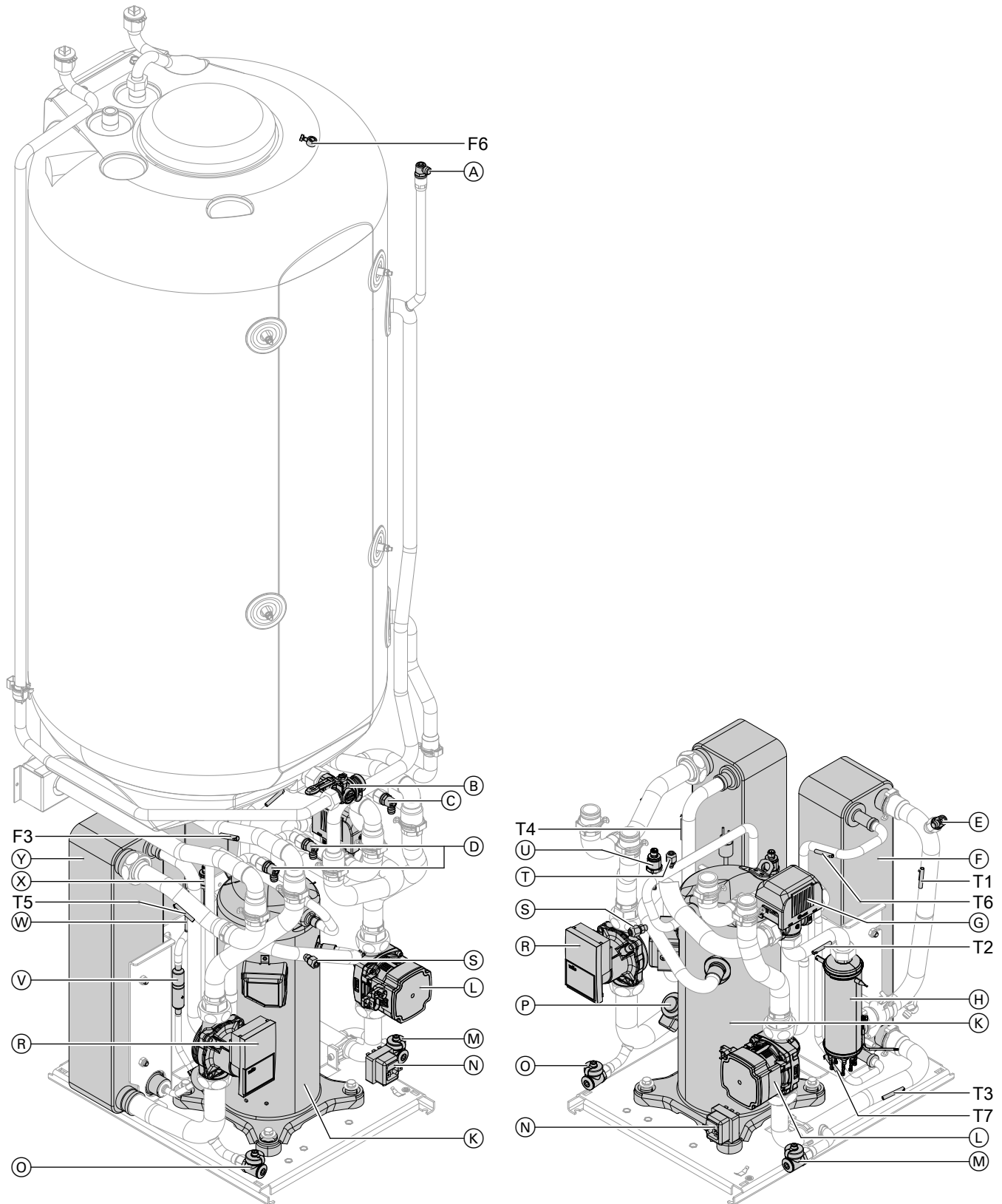

Fig. 54

- (A) Vent valve, secondary circuit
- (B) Drain & fill valve for DHW cylinder
- (C) Vent valve, secondary circuit
- (D) Primary circuit air vent valves
- (E) Condenser air vent valve, secondary side
- (F) Condenser

- (G) 3-way diverter valve "central heating/DHW heating"
- (H) Instantaneous heating water heater
- (K) Compressor
- (L) Secondary pump
- (M) Secondary circuit drain & fill valve

Overview of internal components (cont.)

- Ⓝ High limit safety cut-out, instantaneous heating water heater
- Ⓞ Primary circuit drain & fill valve
- Ⓟ Electronic expansion valve
- Ⓠ Primary pump
- Ⓡ Low pressure Schrader valve
- Ⓢ High pressure Schrader valve
- Ⓣ Low pressure sensor
- Ⓤ Filter
- Ⓥ Safety high pressure switch
- Ⓦ High pressure sensor
- Ⓧ Evaporator
- F3 Primary circuit return temperature sensor (Viessmann Pt500A)
- F6 Cylinder temperature sensor (Viessmann NTC 10 kΩ)
- T1 Secondary circuit flow temperature sensor (NTC 10 kΩ)
- T2 Secondary circuit flow temperature sensor downstream of instantaneous heating water heater (NTC 10 kΩ)
- T3 Secondary circuit return temperature sensor (NTC 10 kΩ)
- T4 Suction gas temperature sensor (NTC 10 kΩ)
- T5 Primary circuit flow temperature sensor (NTC 10 kΩ)
- T6 Hot gas temperature sensor (NTC 10 kΩ)
- T7 Liquid gas temperature sensor (NTC 10 kΩ)

Note regarding the temperature sensors

F.. Temperature sensor is connected to the controller and sensor PCB.

T.. Temperature sensor is connected to EEV PCB.



"Vitotronic 200" service instructions

Draining heat pump on the secondary side

1. Close the on-site boiler drain and fill valve.
2. **Draining the heating water side**
Connect the hose to the secondary circuit drain & fill valve: See chapter "Overview of internal components" on page 70.
Open the secondary circuit drain & fill valve.
3. **Draining the DHW side**
See chapter "Draining the appliance on the DHW side" on page 53.

Checking the temperature sensors

For PCB locations in the heat pump: See page 68.

For sensor locations in the heat pump: See page 70.

Sensor	Test element	Connection
<ul style="list-style-type: none"> ▪ Outside temperature sensor (F0) ▪ Buffer temperature sensor (F4) ▪ Cylinder temperature sensor (F6) ▪ Flow temperature sensor, heating circuit with mixer M2/HC2 (F12) ▪ System flow temperature sensor (F13) ▪ Flow temperature sensor for cooling circuit: Heating circuit without mixer A1/HC1 or separate cooling circuit SKK (F14) ▪ Room temperature sensors 	Viessmann NTC 10 kΩ (blue ID label)	Controller and sensor PCB
<ul style="list-style-type: none"> ▪ Return temperature sensor, primary circuit (F3) 	Viessmann Pt500A (green marking)	Controller and sensor PCB
<ul style="list-style-type: none"> ▪ Flow temperature sensor for secondary circuit (T1) ▪ Flow temperature sensor for secondary circuit, upstream of instantaneous heating water heater (T2) ▪ Secondary circuit return temperature sensor (T3) ▪ Suction gas temperature sensor (T4) ▪ Flow temperature sensor for primary circuit (T5) ▪ Hot gas temperature sensor (T6) ▪ Liquid gas temperature sensor (T7) 	NTC 10 kΩ (no marking)	EEV PCB

Checking the temperature sensors (cont.)

Viessmann NTC 10 k Ω (blue marking)

$\vartheta / ^\circ\text{C}$	R / k Ω	$\vartheta / ^\circ\text{C}$	R / k Ω	$\vartheta / ^\circ\text{C}$	R / k Ω	$\vartheta / ^\circ\text{C}$	R / k Ω	$\vartheta / ^\circ\text{C}$	R / k Ω	$\vartheta / ^\circ\text{C}$	R / k Ω
-40	336.500	-8	49.647	24	10.449	56	2.878	88	0.976	120	0.389
-39	314.870	-7	47.055	25	10.000	57	2.774	89	0.946	121	0.379
-38	294.780	-6	44.614	26	9.572	58	2.675	90	0.918	122	0.369
-37	276.100	-5	42.315	27	9.165	59	2.579	91	0.890	123	0.360
-36	258.740	-4	40.149	28	8.777	60	2.488	92	0.863	124	0.351
-35	242.590	-3	38.107	29	8.408	61	2.400	93	0.838	125	0.342
-34	227.550	-2	36.181	30	8.057	62	2.316	94	0.813	126	0.333
-33	213.550	-1	34.364	31	7.722	63	2.235	95	0.789	127	0.325
-32	200.510	0	32.650	32	7.402	64	2.158	96	0.765	128	0.317
-31	188.340	1	31.027	33	7.098	65	2.083	97	0.743	129	0.309
-30	177.000	2	29.495	34	6.808	66	2.011	98	0.721	130	0.301
-29	166.350	3	28.048	35	6.531	67	1.943	99	0.700	131	0.293
-28	156.410	4	26.680	36	6.267	68	1.877	100	0.680	132	0.286
-27	147.140	5	25.388	37	6.016	69	1.813	101	0.661	133	0.279
-26	138.470	6	24.165	38	5.775	70	1.752	102	0.642	134	0.272
-25	130.370	7	23.009	39	5.546	71	1.694	103	0.623	135	0.265
-24	122.800	8	21.916	40	5.327	72	1.637	104	0.606	136	0.259
-23	115.720	9	20.880	41	5.117	73	1.583	105	0.589	137	0.253
-22	109.090	10	19.900	42	4.917	74	1.531	106	0.572	138	0.247
-21	102.880	11	18.969	43	4.726	75	1.481	107	0.556	139	0.241
-20	97.070	12	18.087	44	4.543	76	1.433	108	0.541	140	0.235
-19	91.600	13	17.251	45	4.369	77	1.387	109	0.526	141	0.229
-18	86.474	14	16.459	46	4.202	78	1.342	110	0.511	142	0.224
-17	81.668	15	15.708	47	4.042	79	1.299	111	0.497	143	0.219
-16	77.160	16	14.995	48	3.889	80	1.258	112	0.484	144	0.213
-15	72.929	17	14.319	49	3.743	81	1.218	113	0.471	145	0.208
-14	68.958	18	13.678	50	3.603	82	1.180	114	0.458	146	0.204
-13	65.227	19	13.069	51	3.469	83	1.143	115	0.445	147	0.199
-12	61.722	20	12.490	52	3.340	84	1.107	116	0.434	148	0.194
-11	58.428	21	11.940	53	3.217	85	1.072	117	0.422	149	0.190
-10	55.330	22	11.418	54	3.099	86	1.039	118	0.411	150	0.185
-9	52.402	23	10.921	55	2.986	87	1.007	119	0.400		

Checking the temperature sensors (cont.)

Viessmann Pt500A (green marking)

$\vartheta / ^\circ\text{C}$	R / Ω	$\vartheta / ^\circ\text{C}$	R / Ω	$\vartheta / ^\circ\text{C}$	R / Ω	$\vartheta / ^\circ\text{C}$	R / Ω	$\vartheta / ^\circ\text{C}$	R / Ω	$\vartheta / ^\circ\text{C}$	R / Ω
-30	441.1	1	502.0	32	562.3	63	623.9	94	681.2	125	739.8
-29	443.1	2	503.9	33	564.2	64	622.0	95	683.1	126	741.7
-28	445.1	3	505.9	34	566.1	65	625.8	96	685.0	127	743.5
-27	447.0	4	507.8	35	568.1	66	627.7	97	686.9	128	745.4
-26	449.0	5	509.8	36	570.0	67	629.7	98	688.8	129	747.3
-25	451.0	6	511.7	37	571.9	68	631.6	99	690.7	130	749.2
-24	453.0	7	513.7	38	573.9	69	633.5	100	692.6	131	751.1
-23	454.9	8	515.6	39	575.8	70	635.4	101	694.4	132	752.9
-22	456.9	9	517.6	40	577.7	71	637.3	102	696.3	133	754.8
-21	458.9	10	519.5	41	579.7	72	639.2	103	698.2	134	756.7
-20	460.8	11	521.5	42	581.6	73	641.1	104	700.1	135	758.6
-19	462.8	12	523.4	43	583.5	74	643.1	105	702.0	136	760.4
-18	464.8	13	525.4	44	585.4	75	645.0	106	703.9	137	762.3
-17	466.7	14	527.3	45	587.4	76	646.9	107	705.8	138	764.2
-16	468.7	15	529.3	46	589.3	77	648.8	108	707.7	139	766.1
-15	470.6	16	531.2	47	591.2	78	650.7	109	709.6	140	767.9
-14	472.6	17	533.2	48	593.2	79	652.6	110	711.5	141	769.8
-13	474.6	18	535.1	49	595.1	80	654.5	111	713.4	142	771.7
-12	476.5	19	537.0	50	597.0	81	656.4	112	715.3	143	773.6
-11	478.5	20	539.0	51	598.9	82	658.3	113	717.2	144	775.4
-10	480.5	21	540.9	52	600.9	83	660.2	114	719.0	145	777.3
-9	482.4	22	542.9	53	602.8	84	662.1	115	720.9	146	779.2
-8	484.4	23	544.8	54	604.7	85	664.0	116	722.8	147	781.0
-7	486.3	24	546.8	55	606.6	86	665.9	117	724.7	148	782.9
-6	488.3	25	548.7	56	608.6	87	667.9	118	726.6	149	784.8
-5	490.2	26	550.6	57	610.5	88	669.8	119	728.5	150	786.7
-4	492.2	27	552.6	58	612.4	89	671.7	120	730.4	151	788.5
-3	494.2	28	554.5	59	614.0	90	673.6	121	732.2	152	790.4
-2	496.1	29	556.5	60	616.2	91	675.5	122	734.1	153	792.3
-1	498.1	30	558.4	61	618.2	92	677.4	123	736.0	154	794.1
0	500.0	31	560.3	62	620.1	93	679.3	124	737.9	155	796.0

Checking the temperature sensors (cont.)

NTC 10 k Ω (no marking)

$\vartheta / ^\circ\text{C}$	R / k Ω	$\vartheta / ^\circ\text{C}$	R / k Ω	$\vartheta / ^\circ\text{C}$	R / k Ω	$\vartheta / ^\circ\text{C}$	R / k Ω	$\vartheta / ^\circ\text{C}$	R / k Ω	$\vartheta / ^\circ\text{C}$	R / k Ω
-40	325.700	-8	49.530	24	10.450	56	2.874	88	0.975	120	0.391
-39	305.400	-7	46.960	25	10.000	57	2.770	89	0.946	121	0.381
-38	286.500	-6	44.540	26	9.572	58	2.671	90	0.917	122	0.371
-37	268.800	-5	42.250	27	9.164	59	2.576	91	0.889	123	0.362
-36	252.300	-4	40.100	28	8.776	60	2.484	92	0.863	124	0.352
-35	236.900	-3	38.070	29	8.406	61	2.397	93	0.837	125	0.343
-34	222.600	-2	36.150	30	8.054	62	2.313	94	0.812	126	0.335
-33	209.100	-1	34.340	31	7.719	63	2.232	95	0.788	127	0.326
-32	196.600	0	32.630	32	7.399	64	2.155	96	0.765	128	0.318
-31	184.900	1	31.020	33	7.095	65	2.080	97	0.743	129	0.310
-30	173.900	2	29.490	34	6.804	66	2.009	98	0.721	130	0.302
-29	163.700	3	28.050	35	6.527	67	1.940	99	0.700	131	0.295
-28	154.100	4	26.680	36	6.263	68	1.874	100	0.680	132	0.288
-27	145.100	5	25.390	37	6.011	69	1.811	101	0.661	133	0.281
-26	136.700	6	24.170	38	5.770	70	1.750	102	0.642	134	0.274
-25	128.800	7	23.020	39	5.541	71	1.692	103	0.624	135	0.267
-24	121.400	8	21.920	40	5.321	72	1.636	104	0.606	136	0.261
-23	114.500	9	20.890	41	5.112	73	1.581	105	0.589	137	0.254
-22	108.000	10	19.910	42	4.912	74	1.529	106	0.573	138	0.248
-21	102.000	11	18.980	43	4.720	75	1.479	107	0.557	139	0.242
-20	96.260	12	18.100	44	4.538	76	1.431	108	0.541	140	0.237
-19	90.910	13	17.260	45	4.363	77	1.385	109	0.527	141	0.231
-18	85.880	14	16.470	46	4.196	78	1.340	110	0.512	142	0.226
-17	81.160	15	15.720	47	4.036	79	1.297	111	0.498	143	0.220
-16	76.720	16	15.000	48	3.884	80	1.256	112	0.485	144	0.215
-15	72.560	17	14.330	49	3.737	81	1.216	113	0.472	145	0.210
-14	68.640	18	13.690	50	3.597	82	1.178	114	0.459	146	0.206
-13	64.950	19	13.080	51	3.463	83	1.141	115	0.447	147	0.201
-12	61.480	20	12.500	52	3.335	84	1.105	116	0.435	148	0.196
-11	58.220	21	11.940	53	3.212	85	1.071	117	0.423	149	0.192
-10	55.150	22	11.420	54	3.095	86	1.038	118	0.412	150	0.187
-9	52.250	23	10.920	55	2.982	87	1.006	119	0.401		

Checking the fuses

For fuse locations: See page 27 onwards.

- Fuse F1 is located on the mains terminal of the heat pump control unit.
Fuse type:
 - 6.3 A H (slow), 250 V~
 - Max. power loss \leq 2.5 W
- Fuse F3 is located on the main PCB.
Fuse type:
 - 2.0 A H (slow), 250 V~
 - Max. power loss \leq 2.5 W

1. Switch OFF the power supply.

Checking the fuses (cont.)

2. Opening the wiring chamber.
3. Check fuses. Replace if necessary.



Danger

Incorrect or improperly fitted fuses can lead to an increased risk of fire.

- Insert fuses without using any force. Position fuses correctly.
- Only use structurally identical types with the same response characteristics.



Danger

Removing the fuse does **not switch the power circuit to zero volt**. Contact with 'live' components can lead to serious injury from electric current.

Before working on the equipment, always ensure that **the power circuit is also at zero volt**.

Appliance is too noisy

Possible causes:

- Casing door is not closed tightly: See page 14.
- Hydraulic lines and electrical cables are touching or coming into contact with other components of the heat pump, e.g. the casing.

Hydraulic parameters report

Setting and test values	Setpoint	Commissioning	Maintenance/Service
Frost protection (brine medium) °C	min. -15		
Testing the external heating circuit pumps			
Circulation pump type			
Circulation pump stage			
Overflow valve setting			
Commissioning, primary circuit			
Primary circuit flow temperature ("Diagnosis" → "System overview") °C			
Primary circuit return temperature ("Diagnosis" → "System overview") °C			
Temperature differential (primary circuit flow/return) ΔT :			
<ul style="list-style-type: none"> ▪ If secondary circuit flow temperature = 35 °C primary circuit flow temperature = 10 °C 	K	3 to 5	
<ul style="list-style-type: none"> ▪ If secondary circuit flow temperature = 35 °C primary circuit flow temperature = 0 °C 	K	2 to 4	
Testing the mixer, heat pump and cylinder heating			
Checked under the following conditions:			
Room temperature °C			
Outside temperature °C			
Temperature "Cylinder temp. top" constant?	Yes (± 1 K)		
Secondary circuit flow temperature °C	Rising	From Open	From Open
Temperature differential ΔT "Flow temp. secondary" / "Return temp. sec." K	6 to 8		

Control parameter report



Parameter description

"Vitotronic 200" service instructions

System definition

Parameter	Code	Delivered condition	Commissioning	Maintenance/service
System scheme (see chapter "Overview of possible system schemes")	7000	2		
Interval for long term average outside temperature	7002	180 min		
Temperature differential for calculating the heating limit	7003	40 (± 4 K)		
Temperature differential for calculating the cooling limit	7004	40 (± 4 K)		
Swimming pool	7008	0		
Primary pump for natural cooling	7007	1		
Output lag heat pump	700B	Never adjust.		

Control parameter report (cont.)

Parameter	Code	Delivered condition	Commissioning	Maintenance/service
External extension	7010	0		
System components for external change-over	7011	0		
Operating status for external changeover	7012	2		
Duration of external changeover	7013	8 h		
Effect of external demand on heat pump/heating circuits	7014	4		
Effect of ext. blocking on heat pump/heating circuits	7015	4		
Vitocom 100 (type GSM/GSM2 only)	7017	0		
Temperature range input 0..10 V	7018	1000		
Priority external demand	7019	0		
Effect of external blocking on pumps/compressor	701A	0		
Common flow temperature sensor system	701B	0		
Operating status after message A9, C9	701C	0		
Effect of OM changeover to ventilation	701F	3		
Select primary source	7030	0		
Start hysteresis solar air absorber	7031	20 (\pm 2 K)		
Solar absorber hysteresis	7032	20 (\pm 2 K)		
Minimum temp. for solar absorber primary source	7033	-500 (\pm -50 °C)		
Average ground temperature in summer mode	7034	40 (\pm 4 °C)		
Min. runtime to suppress summer mode	7035	60 min		
Last calendar week for summer mode	7036	35		
Absorber circuit monitoring	7037	0		
Temperature sensor for dual mode operation	7038	0		
Calendar week, start summer mode, ice store	7039	35		
Calendar week, earliest end summer mode, ice store	703A	35		
Holiday program effect	7050	384		

Compressor

Parameter	Code	Delivered condition	Commissioning	Maintenance/service
Enable use of compressor stage	5012	15		
Primary source output	5043	Do not adjust!		

Control parameter report (cont.)**DHW**

Parameter	Code	Delivered condition	Commissioning	Maintenance/service
Set DHW temperature	6000	500 (\pm 50 °C)		
Min. DHW temperature	6005	100 (\pm 10 °C)		
Max. DHW temperature	6006	600 (\pm 60 °C)		
Hysteresis DHW temperature heat pump	6007	50 (\pm 5 K)		
Hysteresis DHW temperature booster heater	6008	100 (\pm 10 K)		
Start optimisation for DHW heating	6009	0		
Stop optimisation for DHW heating	600A	0		
Set DHW temperature 2	600C	600 (\pm 60 °C)		
Temperature rise per hour for DHW heating	600D	30 K/h		
Max. runtime DHW heating in heating mode	6011	240 (\pm 24 min)		
Max. interruption of DHW heating for central heating	6012	90 (\pm 9 min)		
Enable electric heaters for DHW heating	6015	0		
Start attempts for DHW after high pressure shutdown	6017	0		
Shutdown hysteresis inst. heating water heater	601E	10 (\pm 1 K)		
Enable elec. heating/ext. HS for reheating only	6040	0		
DHW heating blocking time	6060	0 min		
Max. interruption, DHW heating	6061	0 min		

Solar

Parameter	Code	Delivered condition	Commissioning	Maintenance/Service
"Type solar control unit"	7A00	0		
Parameters for solar control module, type SM1	C0xx	These parameters will only be displayed if the solar control module, type SM1, is connected to the heat pump and "Type solar control unit" is set to "3" . For a description of the parameters, see installation and service instructions for "solar control module, type SM1".		

Control parameter report (cont.)**Electric booster heater**

Parameter	Code	Delivered condition	Commissioning	Maintenance/service
"Enable instantaneous heating water heater"	7900	1		
"Enable electric heaters for DHW heating"	7901	0		
"Enable instant. heating water heater for central heating"	7902	0		
"Start delay instantaneous heating water heater"	7905	30 min		
"Max. output instantaneous heating water heater"	7907	3		
"Output for instant. heating water heater at power-OFF"	790A	0		
"Dual mode temp. instant. heating water heater"	790B	500 (\pm 50 °C)		

Internal hydraulics

Parameter	Code	Delivered condition	Commissioning	Maintenance/service
Heat pump for drying a building	7300	0		
Time program for screed drying	7303	0		
Set flow temperature external demand, cooling	730A	Never adjust.		
Set flow temperature external demand	730C	500 (\pm 50 °C)		
Start threshold	730E	300 (\pm 30 K x min)		
Compressor performance at min. outside temperature	730F	50 %		
Compressor performance at max. outside temperature	7310	20 %		
Cooling start threshold	7311	100 (\pm 10 K·min)		
Elec. heater start threshold	7312	300 (\pm 30 K·min)		
Cycle rate heating circuit pumps	7319	0		
Rated output secondary pump (PWM)	7343	100 %		
Rated output heating circuit pump HC2	734A	60 %		
Secondary circuit pump type	735A	Never adjust.		
Starting time, high efficiency circulation pump	7365	Never adjust.		
Screed program start day	7378	1		
Screed program end day	7379	31		

Control parameter report (cont.)**Primary source**

Parameter	Code	Delivered condition	Commissioning	Maintenance/service
Primary source mode	7400	0		
Primary source ctrl strategy	7401	5		
Primary circuit pump type	745A	Never adjust.		
Min. primary circuit inlet temperature in operation	7470	Never adjust.		
Response delay, probe protection	7471	Never adjust.		

Heating water buffer cylinder

Parameter	Code	Delivered condition	Commissioning	Maintenance/service
Enable buffer cylinder/low loss header	7200	0		
Temp in operating status fixed value for buffer cyl	7202	500 (\pm 50 °C)		
Hysteresis temperature heating buffer cylinder	7203	50 (\pm 5 K)		
Max. temperature buffer cylinder	7204	650 (\pm 60 °C)		
Stop optimisation heating buffer cylinder	7205	0		
Temp limit op. status fixed value for buffer cylinder	7208	500 (\pm 50 °C)		
Stop hysteresis, heating water buffer cylinder	7209	0 (\pm 0 K)		
Operating mode, fixed value only for heat demand	720A	0		

Heating circuit 1

Parameter	Code	Delivered condition	Commissioning	Maintenance/Service
"Standard room temperature"	2000	200 (\pm 20 °C)		
"Reduced room temperature"	2001	160 (\pm 16 °C)		
"Remote control"	2003	0		
Room temperature control	2005	0		
"Heating curve level"	2006	0 (\pm 0 K)		
"Heating curve slope"	2007	6 (\pm 0.6)		
"Influence room temperature hook-up"	200 A	10		
"Room temperature hook-up"	200 B	0		
"Max. flow temperature heating circuit"	200E	400 (\pm 40 °C)		
"Room temperature in party mode"	2022	200 (\pm 20 °C)		

Control parameter report (cont.)**Heating circuit 2**

Parameter	Code	Delivered condition	Commissioning	Maintenance/Service
"Standard room temperature"	3000	200 (\pm 20 °C)		
"Reduced room temperature"	3001	160 (\pm 16 °C)		
"Remote control"	3003	0		
Room temperature control	3005	0		
"Heating curve level"	3006	0 (\pm 0 K)		
"Heating curve slope"	3007	6 (\pm 0.6)		
"Influence room temperature hook-up"	300 A	10		
"Room temperature hook-up"	300 B	0		
"Max. flow temperature heating circuit"	300E	400 (\pm 40 °C)		
Runtime mixer heating circ	3015	Do not adjust.		
"Room temperature in party mode"	3022	200 (\pm 20 °C)		
Heating circuit installed	302F	1		

Heating circuit 3

Parameter	Code	Delivered condition	Commissioning	Maintenance/Service
"Standard room temperature"	4000	200 (\pm 20 °C)		
"Reduced room temperature"	4001	160 (\pm 16 °C)		
"Remote control"	4003	0		
Room temperature control	4005	0		
"Heating curve level"	4006	0 (\pm 0 K)		
"Heating curve slope"	4007	6 (\pm 0.6)		
"Influence room temperature hook-up"	400 A	10		
"Room temperature hook-up"	400 B	0		
"Max. flow temperature heating circuit"	400E	400 (\pm 40 °C)		
Runtime mixer heating circ	4015	Do not adjust.		
"Room temperature in party mode"	4022	200 (\pm 20 °C)		

Control parameter report (cont.)**Cooling**

Parameter	Code	Delivered condition	Commissioning	Maintenance/service
Cooling function	7100	0		
Cooling circuit	7101	1		
Set room temperature separate cooling circuit	7102	200 (\pm 20 °C)		
Min. flow temperature cooling	7103	200 (\pm 20 °C)		
Influence room temperature hook-up cooling circuit	7104	0		
Room temperature control cooling circuit	7105	1		
Ranking room temp sensor separate cooling circuit	7106	0		
Hysteresis room temp cooling circuit	7107	10 (\pm 1 K)		
Enable flow temperature sensor cooling circuit	7109	1		
Cooling curve level	7110	0 (\pm 0 K)		
Cooling curve slope	7111	12 (\pm 1.2)		
Remote control cooling circ	7116	Do not adjust!		
Dew point monitor	7117	1		
Cooling integral start threshold	7118	10 %		

Ventilation: Vitovent 200-C and Vitovent 300-F

Parameter	Code	Delivered condition	Commissioning	Maintenance/service
Vitovent enable	7D00	0		
Enable preheater bank electric	7D01	0		
Enable reheater bank hydraulic	7D02	0		
Enable humidity sensor	7D05	0		
Enable CO2 sensor	7D06	0		
Set room temperature	7D08	200 (\pm 20 °C)		
Flow rate reduced ventilation	7D0A	<ul style="list-style-type: none"> ▪ Vitovent 200-C: 75 m³/h ▪ Vitovent 300-F: 120 m³/h 		
Flow rate nominal ventilation	7D0B	<ul style="list-style-type: none"> ▪ Vitovent 200-C: 115 m³/h ▪ Vitovent 300-F: 170 m³/h 		
Flow rate intensive ventilation	7D0C	<ul style="list-style-type: none"> ▪ Vitovent 200-C: 155 m³/h ▪ Vitovent 300-F: 215 m³/h 		
Min. supply air temperature for bypass	7D0F	160 (\pm 16 °C)		
CO2 value for raising the flow rate	7D18	800 ppm		
Humidity value for raising the flow rate	7D19	65 %		
Interval time frost protection ventilation	7D1A	15 min		
Intensive ventilation duration	7D1B	120 min		
Actual source room temperature	7D1D	1		
Heating circuit for blocking bypass damper	7D21	7		

Control parameter report (cont.)

Parameter	Code	Delivered condition	Commissioning	Maintenance/service
Control voltage matching	7D27	0 (\pm 0 V)		
Fan for control voltage matching	7D28	0		
Strategy, passive frost protection	7D2C	0		
Type of heat exchanger	7D2E	0		
Installation position	7D2F	0		
Function, external 230 V input, ventilation	7D3A	0		
Duration, bathroom vent.	7D3B	30 min		
Starting block, ventilation periods part 1	7D5E	0		
Starting block, ventilation periods part 2	7D5F	0		
Control voltage matching, supply air fan	7D71	0 V		
Control voltage matching, exhaust air fan	7D72	0 V		
Sensor matching, outdoor air temperature	7D75	0 K		
Sensor matching, outdoor air temp after pre-heating coil	7D76	0 K		
Sensor matching, supply air temperature	7D77	0 K		
Sensor matching, extract air temperature	7D79	0 K		
Delay, subs. failure ventilation	7D90	0 min		

Ventilation: Vitovent 200-W, Vitovent 300-C and Vitovent 300-W

Parameter	Code	Delivered condition	Commissioning	Maintenance/service
Vitovent enable	7D00	0		
Heating circuit for blocking bypass damper	7D21	7		
Delay, subs. failure ventilation	7D90	0 min		
Preheating coil	C101	1		
Reheater	C102	0		
Humidity sensor	C105	0		
Set CO2 value	C106	0		
Set room temperature	C108	220 (\pm 22 °C)		
Background ventilation	C109	<ul style="list-style-type: none"> ▪ Vitovent 200-W: 15 % ▪ Vitovent 300-C: 30 m³/h ▪ Vitovent 300-W: 50 m³/h 		
Reduced ventilation	C10A	<ul style="list-style-type: none"> ▪ Vitovent 200-W: 25 % ▪ Vitovent 300-C: 75 m³/h ▪ Vitovent 300-W: 100 m³/h 		
Standard ventilation	C10B	<ul style="list-style-type: none"> ▪ Vitovent 200-W: 50 % ▪ Vitovent 300-C: 100 m³/h ▪ Vitovent 300-W: 150 m³/h 		

Control parameter report (cont.)

Parameter	Code	Delivered condition	Commissioning	Maintenance/service
Intensive ventilation	C10C	<ul style="list-style-type: none"> ▪ Vitovent 200-W: 75 % ▪ Vitovent 300-C: 125 m³/h ▪ Vitovent 300-W: 225 m³/h 		
Background ventilation, second fan duct	C189	15 %		
Reduced ventilation, second fan duct	C18A	25 %		
Standard ventilation, second fan duct	C18B	50 %		
Intensive ventilation, second fan duct	C18C	75 %		
Bypass mode	C1A0	0		
Central heating and heat recovery	C1A1	0		
Imbalance permitted	C1A2	1		
Specified imbalance	C1A3	0		
Set reheater coil temperature	C1A4	210 (\pm 21 °C)		
Humidity sensor sensitivity	C1A6	0		
Min. temperature, geothermal heat exchanger	C1AA	50 (\pm 5 °C)		
Max. temperature, geothermal heat exchanger	C1AB	250 (\pm 25 °C)		
Function, input 1	C1B0	0		
Min. voltage, input 1	C1B1	0 (10 \pm 1 V)		
Min. voltage, input 2	C1C1	0 (10 \pm 1 V)		
Flow rate correction	C1C7	100		

Note

The factory settings of parameters C101 to C1C7 depend on the ventilation unit and may differ from the values specified here. The factory setting is displayed in the service menu for each parameter with "**Del con ...**": "▼" See "Vitotronic 200 service instructions".

Control parameter report (cont.)**Photovoltaics**

Parameter	Code	Factory setting	Commissioning	Maintenance/ service
"Enable own energy consumption PV"	7E00	0		
"Prop. of external current"	7E02	10 (\pm 10 %)		
"Threshold for electrical power"	7E04	0 (\pm 0 W)		
Stop threshold (relative)	7E07	0 (\pm 0 kW)		
Enable own energy consumptn for set DHW temperature 2	7E10	0		
Enable own energy consumption for DHW heating	7E11	0		
Enable own energy consumptn for heating water buffer cyl.	7E12	0		
Enable own energy consumption for heating	7E13	0		
"Enable own energy consumption for cooling"	7E15	0		
Raise set DHW cylinder temperature PV	7E21	0 (\pm 0 K)		
Raise set heating water buffer cylinder temp PV	7E22	0 (\pm 0 K)		
"Raise set room temperature PV"	7E23	0 (\pm 0 K)		
"Reduce set room temperature PV"	7E25	0 (\pm 0 K)		

Smart Grid

Parameter	Code	Delivered condition	Commissioning	Maintenance/ Service
"Enable Smart Grid"	7E80	0		
"Smart Grid Enable elec heat"	7E82	0		
"Smart Grid set value increase for DHW heating"	7E91	0 (\pm 0 K)		
"Smart Grid set value increase for htg wtr buff"	7E92	0 (\pm 0 K)		
"Smart Grid set value increase for centr htg"	7E93	0 (\pm 0 K)		
"Smart Grid set value decrease for room t cool"	7E95	0 (\pm 0 K)		

Time

Parameter	Code	Delivered condition	Commissioning	Maintenance/ Service
"Automatic changeover summertime - wintertime"	7C00	1		
"Start summertime - month"	7C01	3		
"Start summertime - week"	7C02	5		
"Start summertime - day"	7C03	7		
"Start wintertime - month"	7C04	10		
"Start wintertime - week"	7C05	5		
"Start wintertime - day"	7C06	7		

Control parameter report (cont.)**Communication**

Parameter	Code	Delivered condition	Commissioning	Maintenance/service
Enable LON communication module	7710	0		
LON subscriber number	7777	1		
LON fault manager	7779	0		
LON system number	7798	1		
Interval for data transfer via LON	779C	20 min		
Source outside temperature	77FC	0		
Send outside temperature	77FD	0		
Source time	77FE	0		
Send time	77FF	0		

Control

Parameter	Code	Delivered condition	Commissioning	Maintenance/service
"Lock out controls"	8800	0		
"Level enable, time program quieter operation"	8801	0		
"User level for display, energy stmt"	8811	1		

Specification for brine/water heat pumps

400 V appliances

Type BWT		221.B06	221.B08	221.B10
Performance data to EN 14511 (B0/W35, 5 K spread)				
Rated heating output	kW	5.76	7.54	10.36
Cooling capacity	kW	4.44	6.06	8.32
Power consumption	kW	1.25	1.62	2.16
Coefficient of performance ϵ (COP)		4.60	4.64	4.81
Brine (primary circuit)				
Capacity	l	3.3	3.3	3.9
Minimum flow rate	l/h	860	1160	1470
Residual head at minimum flow rate	mbar	610	620	580
	kPa	61.0	62.0	58.0
Residual head at nominal flow rate	mbar	586	620	580
	kPa	58.6	62.0	58.0
Max. flow temperature (brine inlet)	°C	25	25	25
Min. flow temperature (brine inlet)	°C	-10	-10	-10
Heating water (secondary circuit)				
Capacity, heat pump	l	3.3	3.5	3.8
Capacity, total	l	226	227	228
Minimum flow rate	l/h	600	710	920
Residual head at minimum flow rate	mbar	600	620	610
	kPa	60.0	62.0	61.0
Residual head at nominal flow rate	mbar	576	620	610
	kPa	57.6	62.0	61.0
Max. flow temperature	°C	65	65	65
Instantaneous heating water heater				
Heating output	kW	9.0		
Rated voltage		3/N/PE 400 V/50 Hz		
Fuse protection		3 x B16A 1-pole		
Heat pump electrical values				
Rated voltage, compressor		3/N/PE 400 V/50 Hz		
Rated current, compressor	A	4.8	6.2	7.4
Cos ϕ		0.9	0.9	0.9
Starting current, compressor with starting current limiter	A	11	14	20
Starting current, compressor with stalled armature	A	28	43	51.5
Compressor fuse rating	A	1 x B16A 3-pole	1 x B16A 3-pole	1 x B16A 3-pole
Rated voltage, heat pump control unit/PCB		1/N/PE 230 V/50 Hz		
Fuse rating, heat pump control unit/PCB (internal)		T 6.3 A (slow) / 250 V		
Power consumption				
Primary pump (high efficiency circulation pump)	W	5 to 70		
▪ Energy efficiency index EEI		≤ 0.21		
Secondary pump (high efficiency circulation pump)	W	5.7 to 87		
▪ Energy efficiency index EEI		≤ 0.21		
Max. power consumption, control unit	W	1000	1000	1000
Rated output, control unit/PCB	W	12	12	12



Specification

Specification for brine/water heat pumps (cont.)

Type BWT		221.B06	221.B08	221.B10
Refrigerant circuit				
Refrigerant		R410A	R410A	R410A
▪ Safety group		A1	A1	A1
▪ Refrigerant charge	kg	1.4	1.95	2.4
▪ Global warming potential (GWP)* ¹		1924	1924	1924
▪ CO ₂ equivalent	t	2.7	3.8	4.6
Permiss. operating pressure				
▪ High pressure side	bar	45	45	45
	MPa	4.5	4.5	4.5
▪ Low pressure side	bar	28	28	28
	MPa	2.8	2.8	2.8
Compressor	Type	Hermetically sealed scroll compressor		
Oil in compressor	Type	Emkarate RL32 3MAF		
Oil volume in compressor	l	0.74	1.24	1.24
Integral DHW cylinder				
Capacity	l	220	220	220
Max. draw-off volume at DHW temperature 40 °C, storage temperature 54 °C and draw-off rate 10 l/min	l	293	293	293
Max. DHW temperature				
▪ Only with heat pump	°C	58	58	58
▪ With instantaneous heating water heater	°C	63	63	63
Max. permiss. DHW temperature	°C	95	95	95
Dimensions				
Total length	mm	680	680	680
Total width	mm	600	600	600
Total height	mm	2000	2000	2000
Weight				
Total weight	kg	277	282	288
Heat pump module	kg	74	77	81
Permiss. operating pressure				
Primary circuit (brine)				
	bar	3.0	3.0	3.0
	MPa	0.3	0.3	0.3
Secondary circuit, heating water				
	bar	3.0	3.0	3.0
	MPa	0.3	0.3	0.3
Secondary circuit, DHW				
	bar	10.0	10.0	10.0
	MPa	1.0	1.0	1.0
Connections				
Primary circuit flow/return	mm	Cu 28 x 1.5	Cu 28 x 1.5	Cu 28 x 1.5
Secondary circuit flow/return	mm	Cu 28 x 1.5	Cu 28 x 1.5	Cu 28 x 1.5
Cold water, DHW (female thread)	Rp	¾	¾	¾
DHW circulation (female thread)	Rp	¾	¾	¾
Sound power (tested with reference to EN 12102/EN ISO 9614-2) – weighted total sound power level at B0 ^{±3 K} /W35 ^{±5 K}				
▪ At rated heating output	dB(A)	40	42	45

*¹ Based on the Fifth Assessment Report of the Intergovernmental Panel on Climate Change (IPCC).

Specification for brine/water heat pumps (cont.)

Type BWT		221.B06	221.B08	221.B10
Energy efficiency class to Commission Regulation (EU) No 813/2013				
Heating, average climatic conditions				
▪ Low temperature application (W35)		A+++	A+++	A+++
▪ Medium temperature application (W55)		A++	A++	A++
DHW heating				
▪ Draw-off profile XL		A+	A+	A+
Heating performance data to Commission Regulation (EU) No 813/2013 (average climatic conditions)				
Low temperature application (W35)				
▪ Energy efficiency η_s	%	186	201	204
▪ Rated heating output P_{rated}	kW	7.0	9.0	12.0
▪ Seasonal coefficient of performance (SCOP)		4.86	5.23	5.32
Medium temperature application (W55)				
▪ Energy efficiency η_s	%	134	143	150
▪ Rated heating output P_{rated}	kW	6.0	8.0	11.0
▪ Seasonal coefficient of performance (SCOP)		3.56	3.79	3.97
▪ DHW heating energy efficiency η_{wh}	%	130	130	130
Sound power level to ErP	dB(A)	40	44	46
230 V appliances				
Type BWT-M		221.B06	221.B08	221.B10
Performance data to EN 14511 (B0/W35, 5 K spread)				
Rated heating output	kW	5.71	7.47	10.29
Cooling capacity	kW	4.32	5.94	8.20
Power consumption	kW	1.36	1.78	2.32
Coefficient of performance ε (COP)		4.20	4.20	4.60
Brine (primary circuit)				
Capacity	l	3.3	3.3	3.9
Minimum flow rate	l/h	860	1160	1470
Residual head at minimum flow rate	mbar	610	620	580
	kPa	61.0	62.0	58.0
Residual head at nominal flow rate	mbar	586	620	580
	kPa	58.6	62.0	58.0
Max. flow temperature (brine inlet)	°C	25	25	25
Min. flow temperature (brine inlet)	°C	-10	-10	-10
Heating water (secondary circuit)				
Capacity, heat pump	l	3.3	3.5	3.8
Capacity, total	l	226	227	228
Minimum flow rate	l/h	600	710	920
Residual head at minimum flow rate	mbar	600	620	610
	kPa	60.0	62.0	61.0
Residual head at nominal flow rate	mbar	576	620	610
	kPa	57.6	62.0	61.0
Max. flow temperature	°C	65	65	65

Specification

Specification for brine/water heat pumps (cont.)

Type BWT-M		221.B06	221.B08	221.B10
Instantaneous heating water heater				
Heating output	kW	9.0		
Rated voltage		1/N/PE 230 V/50 Hz		
Fuse rating		3 x B16A 1-pole		
Heat pump electrical values				
Rated voltage, compressor		1/N/PE 230 V/50 Hz		
Rated current, compressor	A	12.8	17.1	22.8
Cos φ		0.9	0.9	0.9
Starting current, compressor with starting current limiter	A	23.9	25.6	38.7
Starting current, compressor with stalled armature	A	60	83	108
Compressor fuse rating	A	C16A	C20A	B25A
Rated voltage, heat pump control unit/PCB		1/N/PE 230 V/50 Hz		
MCB/fuse, heat pump control unit/PCB (internal)		6.3 A (slow) / 250 V		
Power consumption				
Primary pump (high efficiency circulation pump)	W	5 to 70		
▪ Energy efficiency index EEI		≤ 0.21		
Secondary pump (high efficiency circulation pump)	W	5.7 to 87		
▪ Energy efficiency index EEI		≤ 0.21		
Max. power consumption, control unit	W	1000	1000	1000
Rated output, control unit/PCB	W	12	12	12
Refrigerant circuit				
Refrigerant		R410A	R410A	R410A
▪ Safety group		A1	A1	A1
▪ Refrigerant charge	kg	1.4	1.95	2.4
▪ Global warming potential (GWP) ²		1924	1924	1924
▪ CO ₂ equivalent	t	2.7	3.8	4.6
Permiss. operating pressure				
▪ High pressure side	bar	45	45	45
	MPa	4.5	4.5	4.5
▪ Low pressure side	bar	28	28	28
	MPa	2.8	2.8	2.8
Compressor	Type	Hermetically sealed scroll compressor		
Oil in compressor	Type	Emkarate RL32 3MAF		
Quantity of oil in compressor	l	0.74	1.24	1.24
Integral DHW cylinder				
Capacity	l	220	220	220
Max. draw-off volume at DHW temperature 40 °C, storage temperature 54 °C and draw-off rate 10 l/min	l	293	293	293
Max. DHW temperature				
▪ Only with heat pump	°C	58	58	58
▪ With instantaneous heating water heater	°C	63	63	63
Max. permiss. DHW temperature	°C	95	95	95

² Based on the Fifth Assessment Report of the Intergovernmental Panel on Climate Change (IPCC).

Specification for brine/water heat pumps (cont.)

Type BWT-M		221.B06	221.B08	221.B10
Dimensions				
Total length	mm	680	680	680
Total width	mm	600	600	600
Total height	mm	2000	2000	2000
Weight				
Total weight	kg	277	282	288
Heat pump module	kg	74	77	81
Permiss. operating pressure				
Primary circuit (brine)	bar	3.0	3.0	3.0
	MPa	0.3	0.3	0.3
Secondary circuit, heating water	bar	3.0	3.0	3.0
	MPa	0.3	0.3	0.3
Secondary circuit, DHW	bar	10.0	10.0	10.0
	MPa	1.0	1.0	1.0
Connections				
Primary circuit flow/return	mm	Cu 28 x 1.5	Cu 28 x 1.5	Cu 28 x 1.5
Secondary circuit flow/return	mm	Cu 28 x 1.5	Cu 28 x 1.5	Cu 28 x 1.5
Cold water, DHW (female thread)	Rp	¾	¾	¾
DHW circulation (female thread)	Rp	¾	¾	¾
Sound power level (tested with reference to EN 12102/EN ISO 9614-2) Weighted total sound power level at $B0^{\pm 3 K}/W35^{\pm 5 K}$				
▪ At rated heating output	dB(A)	40	42	45
Energy efficiency class to EU Regulation no. 813/2013				
Heating, average climatic conditions				
▪ Low temperature applications (W35)		A+++	A+++	A+++
▪ Medium temperature applications (W55)		A++	A++	A++
DHW heating				
▪ Draw-off profile XL		A+	A+	A+
Heating performance data in accordance with EU Regulation No. 813/2013 (average climatic conditions)				
Low temperature applications (W35)				
▪ Energy efficiency η_s	%	201	214	194
▪ Rated heating output P_{rated}	kW	6.0	9.0	12.0
▪ Seasonal coefficient of performance (SCOP)		5.23	5.54	5.06
Medium temperature applications (W55)				
▪ Energy efficiency η_s	%	133	151	143
▪ Rated heating output P_{rated}	kW	6.0	8.0	11.0
▪ Seasonal coefficient of performance (SCOP)		3.52	3.98	3.76
▪ DHW heating energy efficiency η_{wh}	%	130	130	130
Sound power level to ErP	dB(A)	40	44	46

Specification for water/water heat pumps

400 V appliances

Type BWT in conjunction with "water/water heat pump conversion kit"		221.B06	221.B08	221.B10
Heating performance data to EN 14511 (W10/W35, 5 K spread)				
Rated heating output	kW	7.53	9.80	13.41
Cooling capacity	kW	5.80	8.52	11.61
Power consumption	kW	1.23	1.57	2.11
Coefficient of performance ϵ (COP)		6.11	6.24	6.37
Brine (primary intermediate circuit)				
Capacity	l	3.3	3.3	3.9
Minimum flow rate	l/h	1440	2120	2880
Residual head at minimum flow rate	mbar	570	300	770
	kPa	57.0	30.0	77.0
Max. flow temperature (brine inlet)	°C	25	25	25
Min. flow temperature (brine inlet)	°C	7.5	7.5	7.5
Heating water (secondary circuit)				
Capacity	l	3.3	3.5	3.8
Minimum flow rate	l/h	650	850	1160
Residual head at minimum flow rate	mbar	610	680	625
	kPa	61.0	68.0	62.5
Max. flow temperature	°C	65	65	65

230 V appliances

Type BWT-M in conjunction with "water/water heat pump conversion kit"		221.B06	221.B08	221.B10
Heating performance data to EN 14511 (W10/W35, 5 K spread)				
Rated heating output	kW	7.62	9.95	13.44
Cooling capacity	kW	6.48	8.60	11.66
Power consumption	kW	1.36	1.64	2.27
Coefficient of performance ϵ (COP)		5.61	6.07	5.92
Brine (primary intermediate circuit)				
Capacity	l	3.3	3.3	3.8
Minimum flow rate	l/h	1600	2130	2890
Residual head at minimum flow rate	mbar	535	295	770
	kPa	53.5	29.5	77.0
Max. flow temperature (brine inlet)	°C	25	25	25
Min. flow temperature (brine inlet)	°C	7.5	7.5	7.5
Heating water (secondary circuit)				
Capacity	l	3.3	3.5	3.8
Minimum flow rate	l/h	660	860	1160
Residual head at minimum flow rate	mbar	608	675	625
	kPa	60.8	67.5	62.5
Max. flow temperature	°C	65	65	65

Note

Further specifications: See "Specification – brine/water heat pumps".

Commissioning order

Email this request form, together with the system scheme, to your local Viessmann sales office.
A competent employee must be present when the system is commissioned.

System details:

Requester _____

System location _____

Checklist:

- Hydraulic scheme for heating system included
- Heating circuits fully installed and filled
- Electrical installation completed
- Hydraulic lines fully thermally insulated
- Installation completed in full up to refrigerant circuit
- All windows and external doors airtight
- Components for cooling mode fully installed (optional)
- Components for ventilation fully installed (optional)
- Components for photovoltaic system fully installed (optional)

Preferred appointment:

1. Date _____
Time _____

2. Date _____
Time _____

The work requested from Viessmann will be billed to me/us in accordance with the latest Viessmann pricelist.

Place/date _____

Signature _____

Declaration of Conformity

Declaration of conformity

We, Viessmann Climate Solutions SE,
D-35108 Allendorf, declare as sole responsible body
that the named product complies with the European
directives and supplementary national requirements in
terms of its design and operational characteristics.

Using the serial number, the Declaration of Conformity
can be found on the following website:
www.viessmann.co.uk/eu-conformity

Keyword index

- A**
- Air vent valve
 - Condenser.....70
 - Air vent valves
 - Primary circuit..... 70
 - Ambient temperatures..... 11
 - Anode connection..... 51
 - Anode earth current..... 52
 - Anode tester..... 52
 - Appliance, draining on DHW side..... 53
 - Appliance fuses..... 74
 - Automatic thermostatic mixing valve..... 21
- B**
- BDF valve..... 71
 - Buffer temperature sensor..... 34, 71
- C**
- Cable length..... 23, 41
 - Cables
 - Inserting..... 24
 - Routing..... 24
 - Central fault message..... 31
 - Checking
 - Fuses..... 74
 - Sensors..... 71
 - Check valve..... 21
 - Cleaning cylinder..... 53
 - Coding card slot..... 35
 - Coding level 1..... 55
 - Coefficients
 - Temperature sensor, type NTC 10 kΩ..... 72, 74
 - Cold water..... 9, 10, 22
 - Commissioning..... 47, 55, 93
 - Commissioning assistant..... 54, 55
 - Commissioning order..... 93
 - Communication module, LON..... 35
 - Components..... 31
 - Compressor..... 70
 - Power cable..... 23
 - Compressor thermal relay..... 68
 - Condenser..... 70
 - Conditions for siting..... 11, 13
 - Connection
 - Cooling circuit..... 20
 - DHW..... 21
 - Electrical components..... 22
 - Overview..... 9
 - Primary circuit..... 18
 - Secondary circuit..... 18, 20
 - Connection conditions..... 40
 - Connection hoses..... 18
 - Connections..... 88, 91
 - Hydraulic..... 18
 - Primary circuit..... 20
 - Connection values
 - Circulation pumps..... 31
 - Function components..... 31
 - Controller and sensor PCB..... 68
 - Control parameter reports..... 76
 - Control PCB..... 34
 - Control unit
 - Controller and sensor PCB..... 34
 - Expansion PCB..... 31
 - Cooling..... 28
 - Cooling circuit..... 20
 - Cooling function..... 60
 - Corrosion damage..... 52, 54
 - Cylinder cleaning..... 53
 - Cylinder temperature sensor..... 71
- D**
- DHW..... 9, 10, 22
 - DHW circulation..... 9, 10, 22
 - DHW circulation connection set..... 22
 - DHW circulation pump..... 21, 29, 58
 - DHW connections..... 22
 - DHW cylinder
 - Cleaning..... 53
 - Filling and venting..... 50
 - DHW side connection..... 21
 - Dimensions..... 9, 88, 91
 - Drain & fill valve
 - DHW cylinder..... 70
 - Primary circuit..... 71
 - Secondary circuit..... 70
 - Draining secondary circuit..... 71
 - Drain valve..... 21
 - Drinking water filter..... 21
- E**
- EA1 extension..... 34
 - Economy tariff..... 40, 41
 - Economy tariff meter..... 42
 - EEV PC..... 68
 - Electrical connection..... 27
 - Inserting cables..... 24
 - Pumps..... 28
 - Electrical connections
 - Checking..... 54
 - Circulation pumps..... 31
 - Controller and sensor PCB..... 34
 - Expansion PCB..... 31
 - Overview..... 68
 - Electrical values, heat pump..... 87, 90
 - Electric booster heater..... 60
 - Electric heater..... 28
 - Electronic expansion valve..... 8, 71
 - Energy efficiency class..... 89, 91
 - Energy meter..... 34
 - Evaporator..... 71
 - Expansion PCB..... 31, 68
 - Expansion vessel..... 20, 48
 - Checking..... 50
 - Extended menu..... 57
 - External extension..... 58
 - External functions..... 59

F		Installation room.....	11
Feed.....	40, 42	Instantaneous heating water heater... 28, 60, 70, 87, 90	
Filling		– Power cable.....	23
– Primary side.....	48	– Resetting.....	65
– Secondary side.....	49	– Resetting high limit safety cut-out.....	65
Fill water.....	49	– Switching module.....	68
Filter.....	71	Instructing system user.....	67
Finished floor.....	12	Intended use.....	7
Floor load.....	11	Internal components.....	70
Flow		Isolators.....	39
– Primary circuit.....	9, 10		
– Secondary circuit.....	9, 10	K	
Flow regulating valve.....	21	KM-BUS distributor.....	34
Flow temperature sensor			
– Cooling circuit.....	34, 71	L	
– Heating circuit.....	71	Leak test.....	45, 66
– Heating circuit with mixer.....	34, 35	Liquid gas temperature sensor.....	71
– Primary circuit.....	71	Low pressure sensor.....	71
– Secondary circuit.....	71	Luster terminals.....	27, 68
– System.....	71		
Front panel, removing.....	13	M	
Frost stat.....	45	Main MCB/fuse, switching on.....	54
Full wave soft starter.....	68	Main PCB.....	68
Function check.....	65	Mains isolator.....	42, 47, 54
Function components.....	28	Mains terminals.....	27, 68
Function test.....	65	Maintenance.....	47, 68
Fuse		Maximum temperature limiter.....	35
– F1.....	74	Minimum clearance.....	11
– F3.....	74	Minimum flow rate.....	20
– Max. power loss.....	74	Minimum room height.....	12
Fuses		Minimum room volume.....	11
– Checking.....	74	Mixer extension kit.....	34, 38, 58
		Modbus distributor.....	35
H			
Heating circuit pump.....	29, 58	N	
Heating performance data.....	89, 91	Noise.....	45, 66, 75
Heating water.....	87, 89	Non-return valve.....	21
Heat pump			
– Checking for noise.....	67	O	
– Closing.....	45, 66	Off signal.....	42
– Levelling.....	18	ON/OFF switch.....	55, 68
– Opening.....	47	On-site connections.....	9
– Siting.....	11, 13	Operating noise.....	67
Heat pump control unit.....	23	Operator's log.....	47
Heat pump module		Optolink.....	68
– Installation.....	17	Outside temperature sensor.....	34, 71
– Removing.....	14	Overflow valve.....	20
Heat transfer medium.....	20, 48	Overview	
High limit safety cut-out.....	71	– Electrical connections.....	68
– Reset.....	65	– Internal components.....	70
High pressure sensor.....	71	– Pumps.....	70
Hot gas temperature sensor.....	71	– Sensors.....	70
Hydraulic connections.....	18	– Valves.....	70
Hydraulic parameters.....	76	Overview of electrical connections.....	27
Hydraulic terminal area.....	21	Overview of system schemes.....	57
I			
Ice store system.....	61		
Impressed current anode.....	52		
Inspection.....	47		

Keyword index (cont.)

P

Parameter group selection.....	57
Parameters	
– Circulation pump for DHW reheating.....	58
– Cooling function.....	60
– DHW circulation pump.....	58
– Electric booster heater.....	60
– Energy meters.....	64
– External extension.....	58
– External functions.....	59
– Heating circuit pump.....	58
– Ice store system.....	61
– Instantaneous heating water heater.....	60
– Mixer extension kit.....	58
– On-site components.....	57
– Photovoltaics.....	64
– Power generated on site.....	64
– Remote control.....	58
– Report.....	76
– Smart Grid.....	64
– Solar DHW heating.....	60
– Swimming pool water heating.....	61
– Temperature sensor, type Pt500A.....	73
– Ventilation.....	61, 62, 63
Parameter setting.....	57
PCB	
– Luster terminals.....	32
– Main PCB.....	28
Performance data.....	87, 89
Permiss. operating pressure.....	88, 91
Photovoltaics.....	64
Pipe entries.....	20
Pipe separator.....	21
Platform for unfinished floors.....	12
Power circuits.....	40
Power consumption.....	87, 90
Power generated on site.....	64
Power-OFF.....	23, 40, 41
– With on-site load disconnection.....	42
– Without on-site load disconnection.....	41
Power-OFF signal.....	41, 44
Power supply	
– Compressor.....	40
– General information.....	39
– Heat pump control unit.....	40
– Instantaneous heating water heater.....	41
– Recommended power cables.....	23
Premium tariff meter.....	42
Pressure check.....	50
Pressure drop curves of sensors.....	71
Pressure gauge connection.....	21
Pressure points.....	12
Pressure reducer.....	21
Primary circuit	
– Connecting.....	20
– Filling and venting.....	48
Primary circuit pressure switch.....	45
Primary pump.....	71
– Setting.....	48
Product information.....	8

Programming unit.....	68
– Opening.....	69
Programming unit cover.....	69
Protective anode check.....	51
Protective magnesium anode.....	51, 52, 54
– Checking.....	51, 52
– Removing.....	52
– Replacing.....	52
– Resistance.....	52, 54
– Short circuit.....	52, 54
Pt500A.....	71
Pumps.....	28, 70

R

RCD.....	41, 42
Recommended power cables.....	23
Refrigerant circuit.....	88, 90
– Checking for leaks.....	47
Refrigerant circuit controller.....	68
Remote control.....	34, 58
Repairs.....	47
Replacing the protective magnesium anode.....	52
Reports.....	76
– Control parameters.....	76
– Writing commissioning reports.....	47
Requirements for installation room.....	11
Residual current device.....	39
Return	
– Primary circuit.....	9, 10
– Secondary circuit.....	9, 10
Return temperature sensor	
– Primary circuit.....	71
– Secondary circuit.....	71
Ripple control receiver.....	42
Room height.....	11, 12
Room temperature sensor.....	34, 71
Room volume.....	11
Routing cables.....	24
Run capacitor.....	68

S

Safety connections.....	32
Safety high pressure switch.....	71
Safety valve.....	20, 21
Schrader valve	
– High pressure.....	71
– Low pressure.....	71
Seal rings, replacing.....	45, 66
Secondary circuit	
– Connecting.....	20
– Draining.....	71
– Filling and venting.....	49
Secondary pump.....	70
Self-consumption.....	43
Sensor PCB.....	34
Sensors.....	70
– Checking.....	71

Service menu		Temperature sensor.....	34
– Activating.....	56	– Coefficients, type NTC 10 kΩ.....	72, 74
– Calling up.....	57	– Parameters, type Pt500A.....	73
– Deactivating.....	56	Terminator, Modbus.....	35
Service termination.....	56	Three-way diverter valve.....	70
Setting primary pump.....	48	Tilting angle.....	11
Signal connections.....	32	TNC system.....	42
Siting.....	11	Top-up water.....	49
Siting conditions.....	13	Total weight.....	12, 88, 91
Smart Grid.....	64	Transport.....	11
– Connection to EA1 extension.....	44	Transport bracket.....	75
– Connection to heat pump control unit.....	44		
Solar DHW heating.....	60	U	
Sound power.....	88	Underfloor heating circuit.....	35
Sound power level.....	89, 91	Utilisation of power generated on site.....	40
Specification			
– Brine/water heat pumps.....	87	V	
– Water/water heat pumps.....	92	Ventilation.....	61, 62, 63
Strain relief fittings.....	68	Venting	
Structure-borne noise transmission.....	13	– Primary side.....	48
Suction gas temperature sensor.....	71	– Secondary side.....	49
Swimming pool.....	38	Vent valve	
Swimming pool water heating.....	61	– Secondary circuit.....	70
Switching module for instantaneous heating water heater.....	68	Volume.....	75
Symbols.....	7		
System filling.....	50	W	
System overview.....	65	Wall clearance.....	11
System pressure.....	50	Warranty.....	55
System scheme.....	57	Water quality.....	49
System user instruction.....	67	Weight.....	12, 88, 91
T			
Temperature differential, primary circuit.....	48		
Temperature limiter.....	35		



Viessmann Climate Solutions SE
35108 Allendorf / Germany
Telephone: +49 6452 70-0
Fax: +49 6452 70-2780
www.viessmann.com



Viessmann Limited
Hortonwood 30, Telford
Shropshire, TF1 7YP, GB
Telephone: +44 1952 675000
Fax: +44 1952 675040
E-mail: info-uk@viessmann.com

6170209 Subject to technical modifications.