

# Installation and service instructions for contractors

**VIESMANN**

## **Vitocal 200-A**

### **Type AWO(-M)/AWO(-M)-E 201.A**

Air source heat pump, monoblock version for heating mode

### **Type AWO(-M)-E-AC 201.A**

Air source heat pump, monoblock version for heating and cooling operation



## **VITOCAL 200-A**





### Safety instructions

 Please follow these safety instructions closely to prevent accidents and material losses.

---

### Safety instructions explained

 **Danger**  
This symbol warns against the risk of injury.

 **Please note**  
This symbol warns against the risk of material losses and environmental pollution.

**Note**  
*Details identified by the word "Note" contain additional information.*

---

### Target group

These instructions are exclusively intended for authorised contractors.

- Work on the refrigerant circuit may only be carried out by authorised refrigeration engineers.
- Work on electrical equipment must only be carried out by a qualified electrician.
- The system must be commissioned by the system installer or a qualified person authorised by the installer.

---

### Regulations to be observed

- National installation regulations
- Statutory regulations for the prevention of accidents
- Statutory regulations for environmental protection
- Codes of practice of the relevant trade associations
- Relevant country-specific safety regulations

**Safety instructions** (cont.)**Safety instructions for working on the system****Working on the system**

- Isolate the system from the power supply, e.g. by removing the separate fuse or by means of a mains isolator, and check that it is no longer live.

**Note**

*In addition to the control circuit there may be several power circuits.*

**Danger**

Contact with live components can result in severe injuries. Some components on PCBs remain live even after the power supply has been switched off.

Prior to removing covers from the appliances, wait at least 4 minutes until the voltage has completely dropped out.

- Safeguard the system against reconnection.
- Wear suitable personal protective equipment when carrying out any work.

**Danger**

Hot surfaces and fluids can lead to burns or scalding.

- Before maintenance and service work, switch OFF the appliance and let it cool down.
- Never touch hot surfaces on the appliance, fittings or pipework.

**Danger**

Risk of fire: Electrostatic discharge can cause sparks which may be ignited by escaping, flammable refrigerant (R32).

Before beginning work, touch earthed objects, such as heating or water pipes, to discharge any static.

**Please note**

Electronic assemblies can be damaged by electrostatic discharge. Prior to commencing work, touch earthed objects such as heating or water pipes to discharge static loads.

**Work on the refrigerant circuit**

Refrigerants are air displacing, colourless, odourless gases.

- R32 forms flammable mixtures with air.
- R410A is not flammable.

**Danger**

Direct contact with liquid and gaseous refrigerant can cause serious damage to health.

- Avoid direct contact with liquid and gaseous refrigerant.
- Wear personal protective equipment when handling liquid and gaseous refrigerant.

**Danger**

Unregulated escape of refrigerant in enclosed spaces can lead to breathing difficulties and suffocation.

- Never breathe in refrigerant vapours.
- Ensure adequate ventilation in enclosed spaces.

Perform the following measures before beginning work on the refrigerant circuit:

- Check the refrigerant circuit for leaks.
- Ensure very good ventilation especially in the floor area and sustain this for the duration of the work.

### Safety instructions (cont.)

- Inform all persons in the vicinity of the system about the type of work to be carried out.
- Secure the area surrounding the work area.

Further measures before starting work on the refrigerant circuit with flammable refrigerants (R32):

- Remove all flammable materials and ignition sources from the immediate vicinity of the heat pump.
- Before, during and after the work, check the surrounding area for escaping refrigerant using a suitable refrigerant detector.  
This refrigerant detector must not generate any sparks and must be suitably sealed.
- A CO<sub>2</sub> or powder extinguisher must be to hand in the following cases:
  - Refrigerant is being topped up.
  - Soldering or welding work is being carried out.
- Display signs prohibiting smoking.

#### **Danger**

Damage to the refrigerant circuit can cause refrigerant to enter the hydraulic system. This can cause serious damage to health.

After completion of the work, professionally vent the hydraulic system on the primary and secondary sides.

## Repair work

### **Please note**

Repairing components that fulfil a safety function can compromise the safe operation of the system. Replace faulty components only with genuine Viessmann spare parts.

## Auxiliary components, spare and wearing parts

### **Please note**

Spare and wearing parts that have not been tested together with the system can compromise its function. Installing non-authorised components and making non-approved modifications or conversions can compromise safety and may invalidate our warranty. For replacements, use only original spare parts supplied or approved by Viessmann.

---

## Safety instructions for operating the system

### What to do if water escapes from the appliance

#### **Danger**

If water escapes from the appliance there is a risk of electrocution. Switch OFF the heating system at the external isolator (e.g. fuse box, domestic distribution board).



#### **Danger**

If water escapes from the appliance there is a risk of scalding. Never touch hot heating water.



## Index









<b>1. Information</b>	Disposal of packaging .....	7
	Symbols .....	7
	Intended use .....	7
	Product information .....	8
	■ Maintenance parts and spare parts .....	9
<b>2. Preparing for installation</b>	Requirements for on-site connections .....	10
	■ Indoor unit .....	10
	■ Outdoor unit .....	11
<b>3. Installation sequence</b>	Installing the outdoor unit .....	13
	■ Transport .....	13
	■ Installation information .....	13
	■ Installation location .....	15
	■ Minimum clearances for 1 outdoor unit .....	15
	■ Minimum clearances for heat pump cascades (max. 5 outdoor units) .....	16
	■ Floorstanding installation .....	17
	■ Wall mounting .....	23
	■ Opening the wiring chamber .....	25
	■ Removing the transport brackets .....	26
	■ Connecting the supplied hoses .....	27
	Installing the indoor unit .....	27
	■ Transport .....	27
	■ Requirements for the installation room .....	28
	■ Minimum clearances .....	28
	■ Fitting the indoor unit to the wall .....	28
	Connecting the secondary circuit .....	30
	Only type AWO(-M)-E-AC 201.A: Connecting the cooling circuit .....	31
	■ Contact humidistat .....	31
	Electrical connection .....	31
	■ Preparing the electrical connections .....	31
	■ Indoor unit: Routing cables to the wiring chamber .....	33
	■ Connecting the Vitoconnect (accessories) .....	34
	■ Indoor unit: Electrical terminal areas .....	36
	■ Indoor unit: Main PCB (230 V~ components) .....	37
	■ Indoor unit: Expansion PCB on main PCB (230 V~ components) .....	40
	■ Indoor unit: Luster terminals (signal and safety connections) .....	43
	■ Indoor unit: Controller and sensor PCB (extra low voltage (ELV) connections) .....	44
	■ Outdoor unit: Routing cables to the wiring chamber .....	47
	■ Outdoor unit: Electrical terminal areas .....	48
	■ Connecting the Modbus cable between the indoor and outdoor unit .....	49
	Power supply .....	50
	■ Heat pump control unit power supply 230 V~ .....	51
	■ Instantaneous heating water heater power supply .....	51
	■ Outdoor unit: Power supply .....	53
	■ Power supply with power-OFF: Without on-site load disconnection .....	55
	■ Power supply with power-OFF: With on-site load disconnection .....	55
	■ Connecting the power-OFF signal in heat pump cascades .....	56
	■ Mains power supply in conjunction with self-consumption .....	57
	■ Smart Grid .....	57
	Closing the heat pump .....	59
	■ Indoor unit: Fitting the front panel .....	59
	■ Outdoor unit: Fitting the side cover .....	59
<b>4. Commissioning, inspection, maintenance</b>	Steps - commissioning, inspection and maintenance .....	60
<b>5. Maintenance</b>	Overview of electrical components .....	78
	Indoor unit: Opening the programming unit .....	78

	Indoor unit: Placing the control unit panel in its service position .....	79
	Indoor unit: Overview of internal components .....	80
	Outdoor unit: Overview of internal components .....	80
	■ Outdoor unit with 1 fan .....	81
	■ Outdoor unit with 2 fans .....	82
	Draining secondary side heat pump .....	83
	Checking the temperature sensors .....	83
	■ Connection to the indoor unit .....	83
	■ Connection to the outdoor unit .....	83
	■ Indoor unit: Viessmann NTC 10 kΩ (blue marking) .....	84
	■ Indoor unit: Viessmann NTC 20 kΩ (orange marking) .....	85
	■ Indoor unit: Viessmann Pt500A (green marking) .....	86
	■ Outdoor unit: Viessmann NTC 10 kΩ (no marking) .....	87
	Checking the fuses .....	87
<b>6. Commissioning/service reports</b>	Hydraulic parameter report .....	89
	Control parameter report .....	89
<b>7. Specification</b>	.....	101
<b>8. Appendix</b>	Commissioning order .....	108
	Final decommissioning and disposal .....	108
<b>9. Certificates</b>	Declaration of conformity .....	109
<b>10. Keyword index</b>	.....	110







## Disposal of packaging

Please dispose of packaging waste in line with statutory regulations.

## Symbols

Symbol	Meaning
	Reference to other document containing further information
	Step in a diagram: The numbers correspond to the order in which the steps are carried out.
	Warning of material losses and environmental pollution
	Live electrical area
	Pay particular attention.
	<ul style="list-style-type: none"> <li>Component must audibly click into place. or</li> <li>Acoustic signal</li> </ul>
	<ul style="list-style-type: none"> <li>Fit new component. or</li> <li>In conjunction with a tool: Clean the surface.</li> </ul>
	Dispose of component correctly.
	Dispose of component at a suitable collection point. Do <b>not</b> dispose of component in domestic waste.

The steps in connection with commissioning, inspection and maintenance are found in the "Commissioning, inspection and maintenance" section and identified as follows:

Symbol	Meaning
	Steps required during commissioning
	Not required during commissioning
	Steps required during inspection
	Not required during inspection
	Steps required during maintenance
	Not required during maintenance

## Intended use

The appliance is only intended to be installed and operated in sealed unvented heating systems that comply with EN 12828, with due attention paid to the associated installation, service and operating instructions.

Depending on the version, the appliance can only be used for the following purposes:

- Central heating
- Central cooling
- DHW heating

The range of functions can be extended with additional components and accessories.

Intended use presupposes that a fixed installation in conjunction with permissible, system-specific components has been carried out.

Commercial or industrial usage for a purpose other than central heating/cooling or DHW heating shall be deemed inappropriate.

**Intended use** (cont.)

Incorrect usage or operation of the appliance (e.g. the appliance being opened by the system user) is prohibited and will result in an exclusion of liability. Incorrect usage also occurs if the components in the heating system are modified from their intended function.

**Note**

*The appliance is intended exclusively for domestic or semi-domestic use, i.e. even users who have not had any instruction are able to operate the appliance safely.*

**Product information****Layout**

Vitocal 200-A is a monoblock air/water heat pump, comprising 1 indoor unit and 1 outdoor unit.

**Refrigerant circuit**

All components of the refrigerant circuit are located in the outdoor unit, including the refrigerant circuit controller with electronic expansion valve. Subject to operating conditions, compressor output is matched via inverter control.

For central cooling, the refrigerant circuit is reversed (only types with designation "-AC").

**Hydraulics**

The indoor and outdoor units are connected to each other hydraulically on the secondary side. The hydraulic components for the secondary circuit are located in the indoor unit. The heated heating water is pumped into the secondary circuit by the integral high efficiency circulation pump (secondary pump). The integral 3-way diverter valve for "central heating/DHW heating" changes over between central heating and DHW heating.

**System without buffer cylinder**

- **Room heating**

The heat pump heats 1 heating/cooling circuit without mixer.

- **Room cooling**

The heat pump cools through 1 heating/cooling circuit without mixer or through 1 separate cooling circuit.

**System with heating water buffer cylinder**

- **Central heating**

The heat pump heats up to 3 heating/cooling circuits: 1 heating/cooling circuit without mixer and 2 heating/cooling circuits with mixer

- **Central cooling**

The heat pump can only cool either through one of the max. 3 heating/cooling circuits or through a separate cooling circuit.

The heating water buffer cylinder is bypassed hydraulically by a bypass circuit.

**System with heating water/coolant buffer cylinder**

- **Central heating**

The heat pump can heat up to 3 heating/cooling circuits: 1 heating/cooling circuit without mixer and 2 heating/cooling circuits with mixer

- **Central cooling**

The heat pump can cool through up to 3 heating/cooling circuits. Central cooling via a separate cooling circuit is not possible.

**Heat pump control unit**

The entire heating system is monitored and controlled by heat pump control unit Vitotronic 200, type WO1C. The heat pump control unit is integrated into the indoor unit. The indoor and outdoor units communicate via Modbus.

## Product information (cont.)

### Type overview

Type	Instantaneous heating water heater	Room cooling	Rated voltage	
			Indoor unit	Outdoor unit
AWO 201.A	—	—	230 V~	400 V~
AWO-M 201.A	—	—	230 V~	230 V~
AWO-E 201.A	X	—	230 V~	400 V~
AWO-M-E 201.A	X	—	230 V~	230 V~
AWO-E-AC 201.A	X	X	230 V~	400 V~
AWO-M-E-AC 201.A	X	X	230 V~	230 V~

### System examples

Available system examples: See [www.viessmann-schemes.com](http://www.viessmann-schemes.com).

### Maintenance parts and spare parts

Maintenance parts and spare parts can be identified and ordered directly online.

#### Viessmann Partnership

Login:  
<https://shop.viessmann.com/>



#### Viessmann spare part app

[www.viessmann.com/etapp](http://www.viessmann.com/etapp)



## Requirements for on-site connections

### Indoor unit

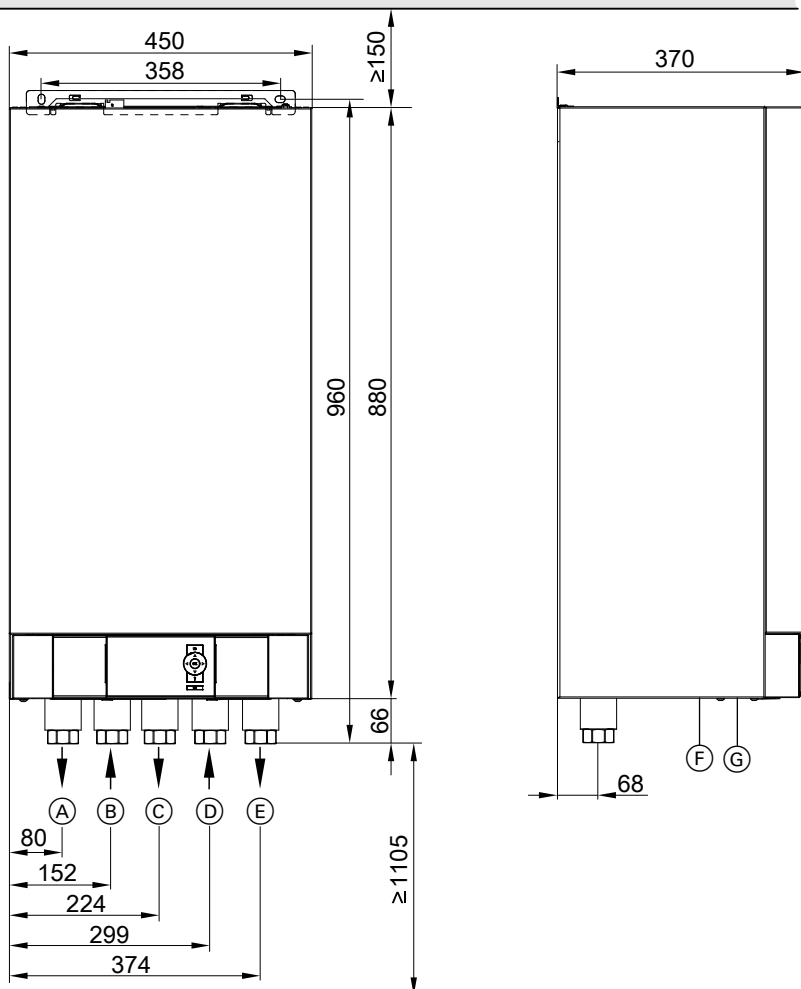

Fig. 1

- Ⓐ Heating water **to** outdoor unit: G 1¼ (union nut DN 32, female thread)
- Ⓑ Heating water **from** outdoor unit G 1¼ (union nut DN 32, female thread)
- Ⓒ DHW cylinder flow (on the heating water side) G 1¼ (union nut DN 32, female thread)
- Ⓓ Heating water return and DHW cylinder return: G 1¼ (union nut DN 32, female thread)
- Ⓔ Heating water flow G 1¼ (union nut DN 32, female thread)
- Ⓕ Cable entry for extra low voltage (ELV) leads < 42 V
- Ⓖ Cable entry for power cables 400 V~/230 V~, > 42 V

Requirements for on-site connections (cont.)

Outdoor unit

Outdoor unit with 1 fan

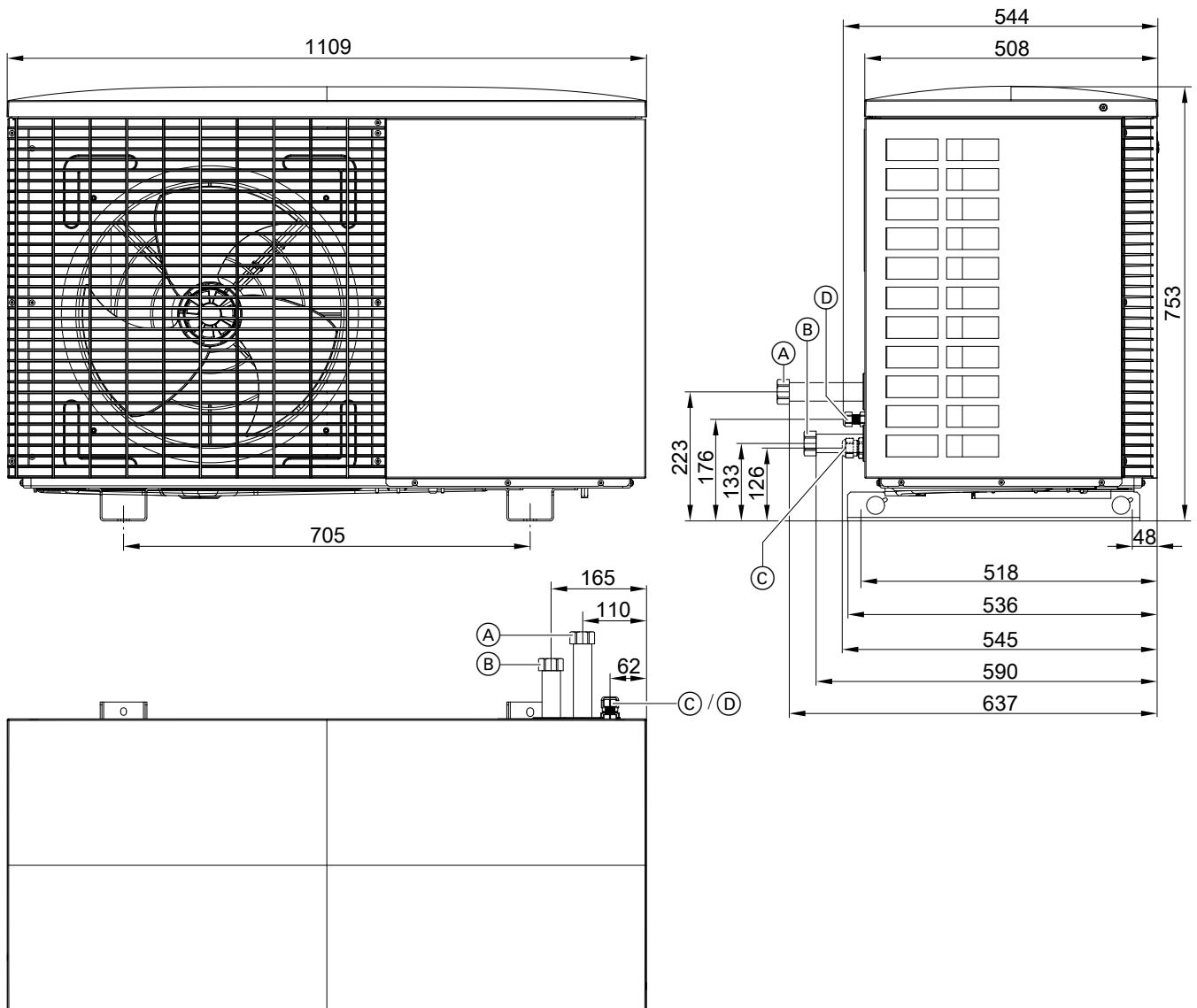

Fig. 2

- (A) Heating water **to** indoor unit: G 1¼ (union nut enclosed, female thread)
- (B) Heating water **from** indoor unit G 1¼ (union nut enclosed, female thread)
- (C) Power cable inlet
- (D) Modbus cable inlet for indoor/outdoor unit



Outdoor unit with 2 fans

Installation

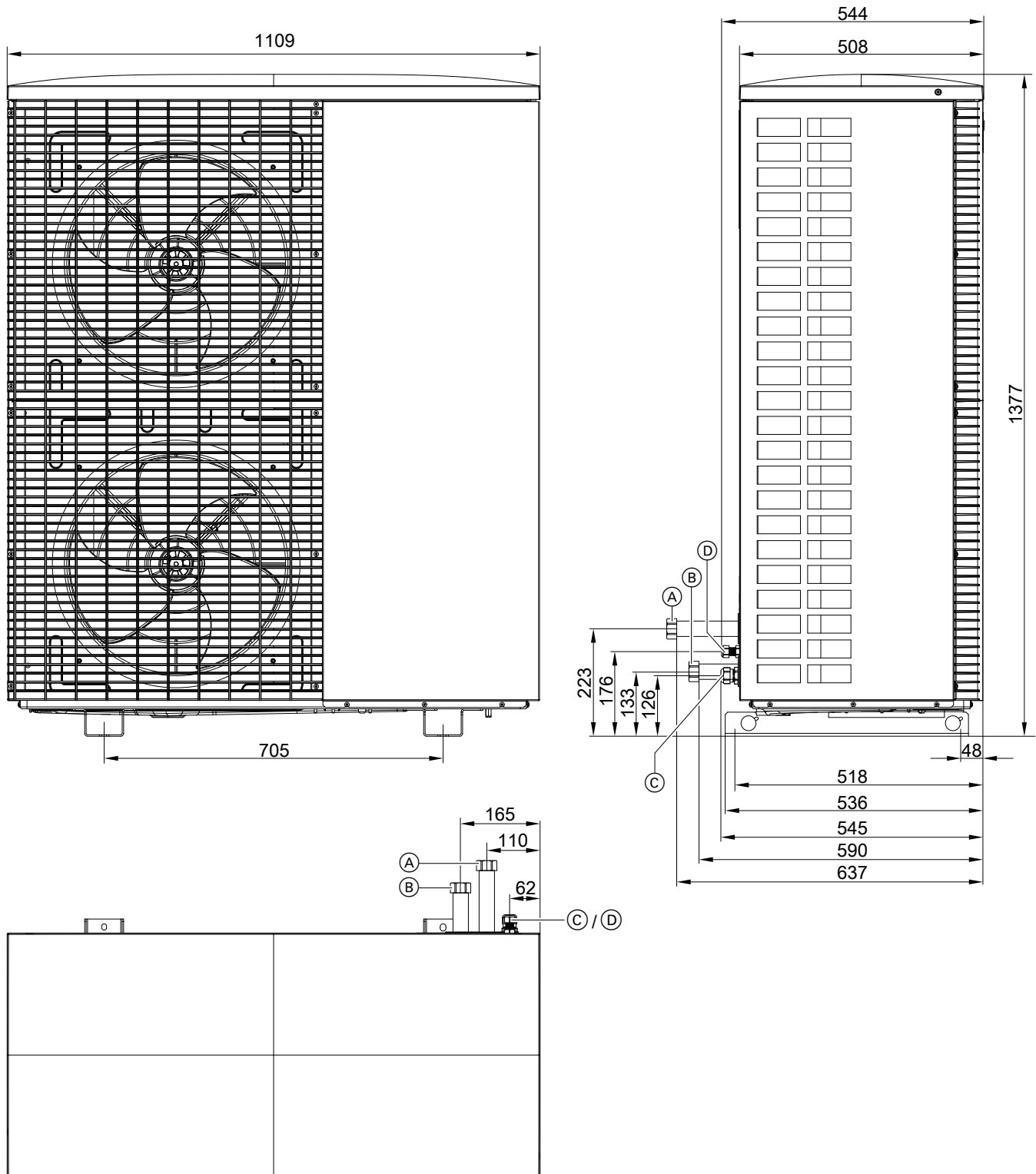

Fig. 3

- (A) Heating water **to** indoor unit: G 1¼ (union nut enclosed, female thread)
- (B) Heating water **from** indoor unit G 1¼ (union nut enclosed, female thread)
- (C) Power cable inlet
- (D) Modbus cable inlet for indoor/outdoor unit

## Installing the outdoor unit

### Transport

- !** **Please note**  
Impacts, compression and tensile loads can cause damage to the outside panels of the appliance.  
**Never** apply loads/weight to the top, front or side panels of the appliance.

- !** **Please note**  
If the compressor in the outdoor unit is tilted too far, lubricant will enter the refrigerant circuit and damage the appliance.  
Max. tilting angle: 45° for approx. 4 min, otherwise 30°

### Installation information

#### Types of installation

- Floorstanding installation with line entry above ground level
- Floorstanding installation with line entry below ground level
- Wall mounting
- Flat roof installation

#### Floorstanding installation

- Use supports for floorstanding installation (accessories).  
Use ground anchors with a tensile force of at least 2.5 kN to secure the support.
- Where such supports cannot be used, install the outdoor unit freestanding on a solid base (provided on site) with a height of at least 100 mm.
- In difficult climatic circumstances (temperatures below zero, snow, humidity), we recommend installing the appliance on a plinth of approx. 300 mm height.
- Take account of the weight of the outdoor unit: See "Specification".

#### Wall mounting

- Use the wall mounting bracket set (accessories).
- The wall must meet the structural requirements.  
Use suitable fixing materials, depending on the wall structure.

#### Flat roof installation

When installing on a flat roof, the following additional engineering measures, amongst others, must be taken into account:

#### Note

*Due to the higher static loads (roof/wind load) and the higher acoustic requirements for flat roof installation, the structural calculations and sound concept require input from specialist design engineers.*

#### Installation location:

- Never install the outdoor unit on a flat roof immediately next to or above living rooms or bedrooms. Avoid siting in front of windows.
- As the outdoor unit is located higher up when installed on a flat roof, operating noise propagation is more intense than when the unit is installed on the ground. Roof surfaces are normally more reverberant than areas on the ground.  
To prevent noise nuisance, install the outdoor unit at a sufficient distance from neighbouring buildings. If required, provide suitable noise reduction measures. Take into account sound reflection from the surfaces of buildings when analysing sound propagation: See technical guide.
- Check to ensure that the installed height of the outdoor unit does not exceed the permissible building height, e.g. as specified in outline planning restrictions.
- Provide easy, year-round access to the outdoor unit for service and maintenance. Provide sufficient maintenance areas.  
Install suitable protection equipment, e.g. anchorage points.

#### Substructure:

- We recommend installing the heat pump on a steel-reinforced concrete ceiling.
- Installation on flat roofs with a low weight per unit area (e.g. roofs made from timber rafters or trapezoidal sheet metal) is **not permissible**.
- The higher roof and wind loads must be taken into account in the structural calculations and the fixture system.
- Where heat pumps are installed on a flat roof, considerable wind loads may occur, depending on the relevant wind zone and the height of the building. We recommend having the substructure designed to DIN 1991-1-4 by a specialist design engineer.

## Installing the outdoor unit (cont.)

### Siting

- Do not install with the discharge side facing the main wind direction.
- Do not mount the outdoor unit above cellar shafts or floor troughs.
- Provide wall outlets and protective conduits for the hydraulic connection lines and electrical connecting cables without moulded parts or changes of direction.

### Weather influences

- Observe wind loads when installing the unit on sites exposed to the wind.  
Where outdoor units are installed on a flat roof, considerable wind loads may occur, depending on the relevant wind load zone and height of the building. For such installation situations we recommend having the substructure sized by a design engineer in accordance with DIN 1991-1-4.
- Provide thermal insulation of sufficient thickness on the pipework to the outdoor air: See following table.

Pipework internal $\varnothing$	Min. thickness of thermal insulation layer with $\lambda = 0.035 \text{ W/(m}\cdot\text{K)}$
$\leq 22 \text{ mm}$	40 mm
$> 22 \text{ mm}$	60 mm

$\lambda$  Thermal conductivity

- Incorporate the outdoor unit into the lightning protection system.
- Note the heat absorbed (heating mode) and heat emitted (cooling mode) by the appliance when designing weatherproofing measures or an enclosure.

### Condensate

Floorstanding and wall installation:

- Ensure that condensate can drain freely.  
Create a permanent gravel bed under the outdoor unit as a soakaway.
- In regions where the outside temperature regularly falls below  $0 \text{ }^\circ\text{C}$  we recommend fitting an electric ribbon heater (accessories) for the condensate pan of the outdoor unit.

Flat roof installation:

- Allowing the condensate to drain freely onto the roof surface is not permissible, as this may result in the formation of layers of ice. Layers of ice on the roof may prevent further condensate from draining freely, resulting in increased roof loads.
- Use an electric ribbon heater for the condensate pipe (accessories).
- To drain the condensate, connect the condensate hose on the outdoor unit to an insulated condensate pipe. The condensate hose is included in the standard delivery of the electric ribbon heater.  
If required, insert the condensate hose via a trap insert.

### Structure-borne noise insulation and vibration isolation between the building and outdoor unit

- Route cables/leads between the indoor and outdoor units so they are not stressed.
- Installation only on walls with a high weight per unit area ( $> 250 \text{ kg/m}^2$ ); in other words not on lightweight walls, roof structures, etc.
- Vibration isolation components are included in the standard delivery of the wall mounting bracket.  
Do not use additional anti-vibration mounts, springs, rubber mounts, etc.
- When installing the outdoor unit on roof surfaces, there is a risk that structure-borne noise and vibrations will be transmitted into the building.  
If the outdoor unit is installed on freestanding garages, insufficient structure-borne noise insulation and vibration isolation can cause excessive noise due to resonance amplification: See technical guide.

### Weight of outdoor units

#### Heat pumps with outdoor unit 230 V

Types	Weight in kg
201.A04	102
201.A06	102
201.A08	103
201.A10	145
201.A13	145
201.A16	145

#### Heat pumps with outdoor unit 400 V

Types	Weight in kg
201.A10	153
201.A13	153
201.A16	153

**Installing the outdoor unit (cont.)**

**Installation location**

- Select a site with good air circulation, so that the cooled air can dissipate and be replaced by warm air.
- Never install in the corners of rooms, in recesses or between walls. This could result in an "air short circuit" between the air being discharged and the air being drawn in.

**! Please note**  
 An "air short circuit" during **heating mode** will result in the cooled, discharged air re-entering the unit. This can result in reduced heat pump efficiency and defrosting problems. Avoid "air short circuits".

**! Please note**  
 An "air short circuit" during **cooling mode** will result in the heated, discharged air re-entering the unit. This can lead to high pressure faults. Avoid "air short circuits".

- If siting the appliance in a location that is exposed to wind, ensure that the wind cannot influence the fan area. Strong wind can have a negative influence on the air flow through the evaporator.

- For flat roof installation, provide on-site measures for wind protection if necessary, e.g. panels, walls, etc.
- Select an installation location where the evaporator cannot be blocked by leaves, snow, etc.
- Select the installation location giving due consideration to the physical laws concerning the propagation and reflection of sound.

 Technical guide

- Never install next to or below bedroom windows.
- Maintain a clearance of at least 3 m to pathways, downpipes or sealed surfaces. The cooled air in the discharge area creates a risk of ice forming when outside temperatures are below 10 °C.
- The installation location must be easily accessible, for example for maintenance work: See "minimum clearances".

**Minimum clearances for 1 outdoor unit**

**Outdoor unit with 1 fan**

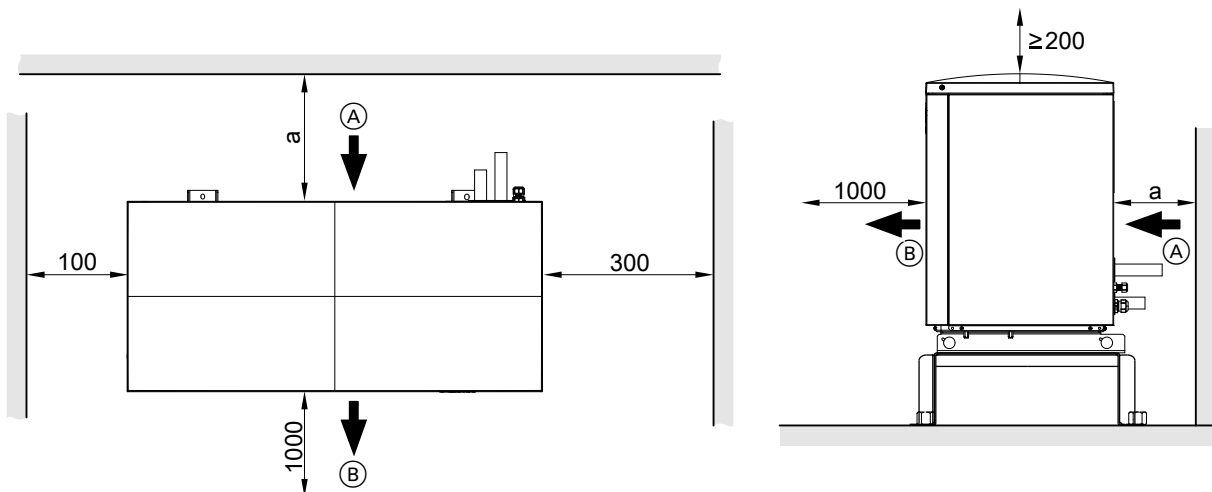

Fig. 4

- (A) Air intake
- (B) Air discharge
- a
  - Line entry above ground level:  $\geq 200$  mm
  - Line entry below ground level:  $\geq 900$  mm

Outdoor unit with 2 fans

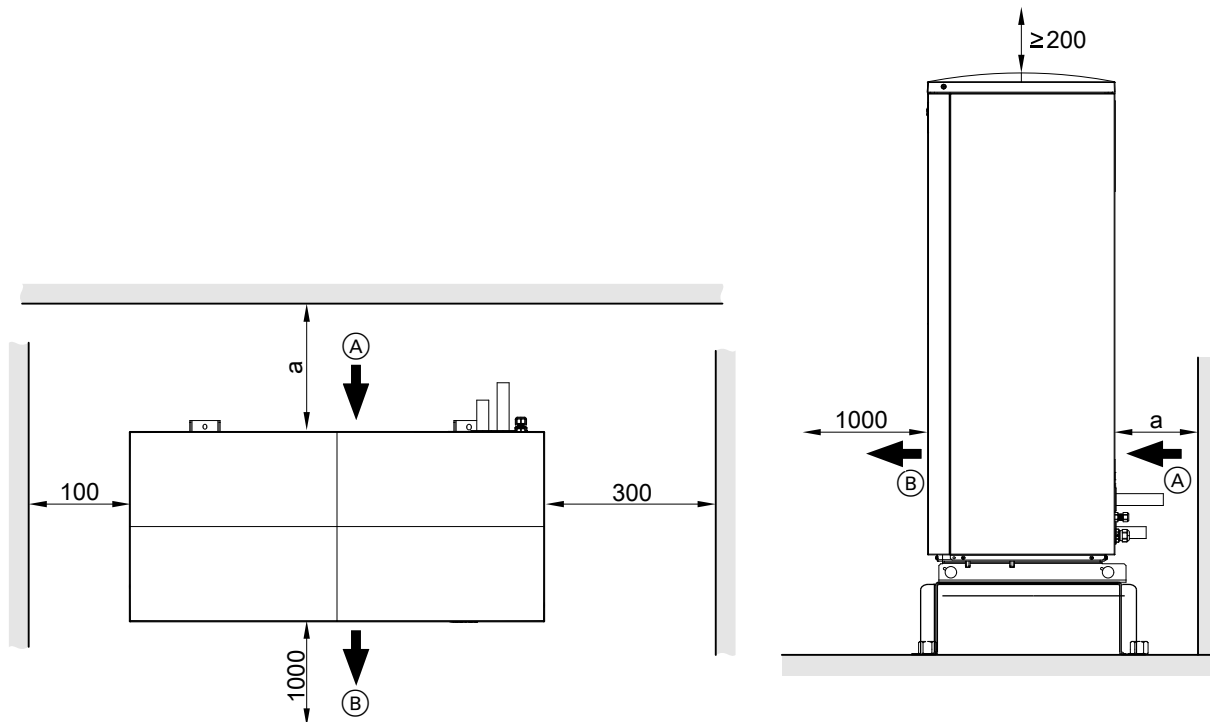

Fig. 5

(A) Air intake

(B) Air discharge

- a ■ Line entry above ground level:  $\geq 200$  mm
- Line entry below ground level:  $\geq 900$  mm

Minimum clearances for heat pump cascades (max. 5 outdoor units)

Facing layout without partition wall

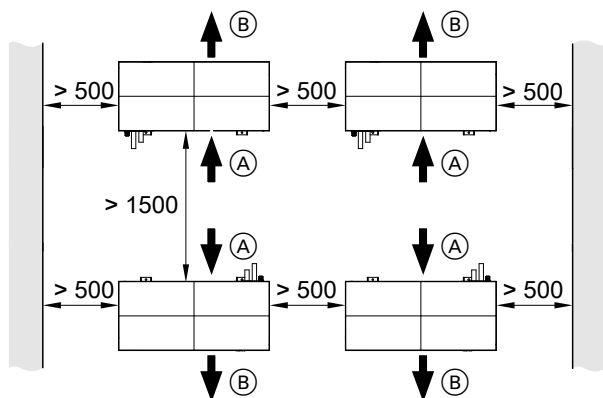

Fig. 6

(A) Air intake

(B) Air discharge

Facing layout with partition wall

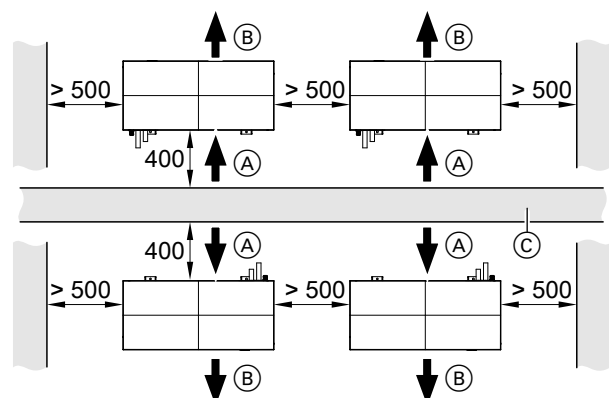

Fig. 7

(A) Air intake

(B) Air discharge

## Installing the outdoor unit (cont.)

### Single row layout

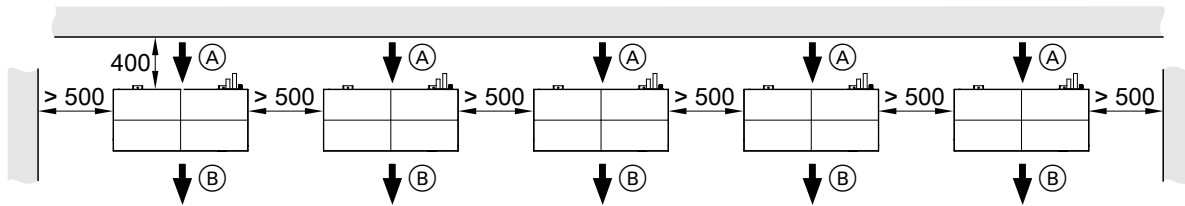

Fig. 8

- Ⓐ Air intake
- Ⓑ Air discharge

## Floorstanding installation

### Foundations

Fit the floor brackets on 2 horizontal foundation strips. We recommend the construction of concrete foundations in accordance with the following diagram. The stated thickness of the layers represents an average value. These values should be adjusted to suit the local conditions. Follow the standard rules of building engineering.

For support for floorstanding installation

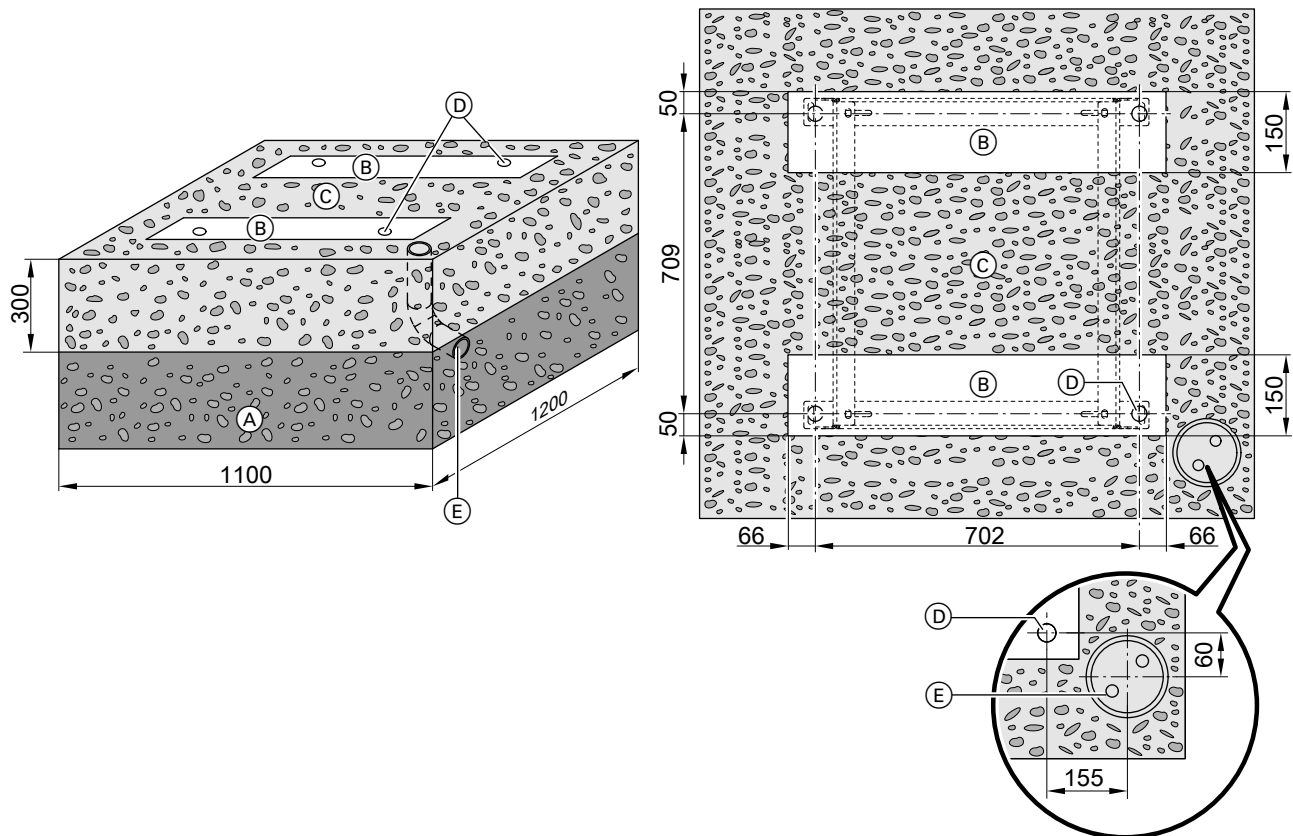

Fig. 9

- (A) Frost protection for foundations (compacted crushed stone, e.g. 0 to 32/56 mm); thickness of layer subject to local requirements and building regulations
- (B) Foundation strip
- (C) Gravel bed as condensate soakaway
- (D) Fixing points for support  
Use ground anchors with a tensile force of at least 2.5 kN.
- (E) Only for line entry below ground level: Hydraulic connection set (accessories)



Installing the outdoor unit (cont.)

For design casing with support

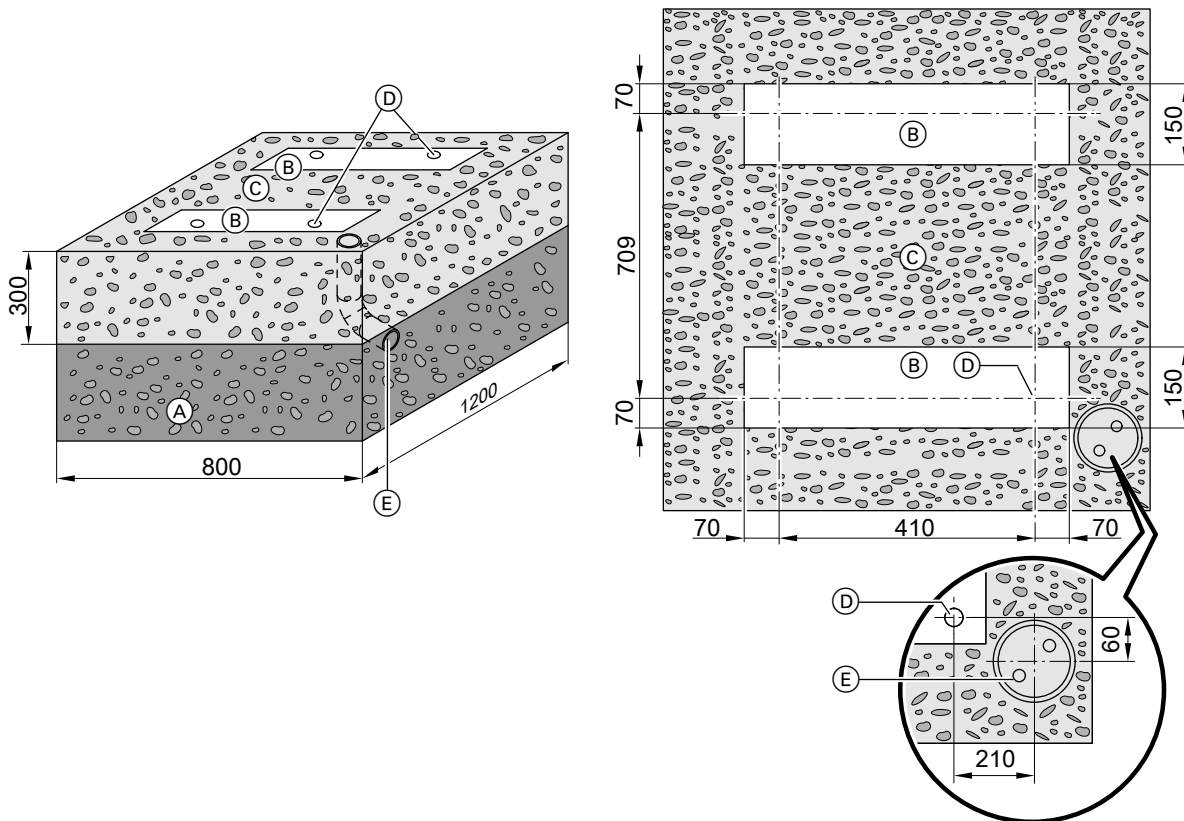

Fig. 10

- Ⓐ Frost protection for foundations (compacted crushed stone, e.g. 0 to 32/56 mm); thickness of layer subject to local requirements and building regulations
- Ⓑ Foundation strip
- Ⓒ Gravel bed as condensate soakaway
- Ⓓ Fixing points for support  
Use ground anchors with a tensile force of at least 2.5 kN.
- Ⓔ Only for line entry below ground level: Hydraulic connection set (accessories)

**Installing the outdoor unit** (cont.)

**Floorstanding installation with support: Line entry above ground level**

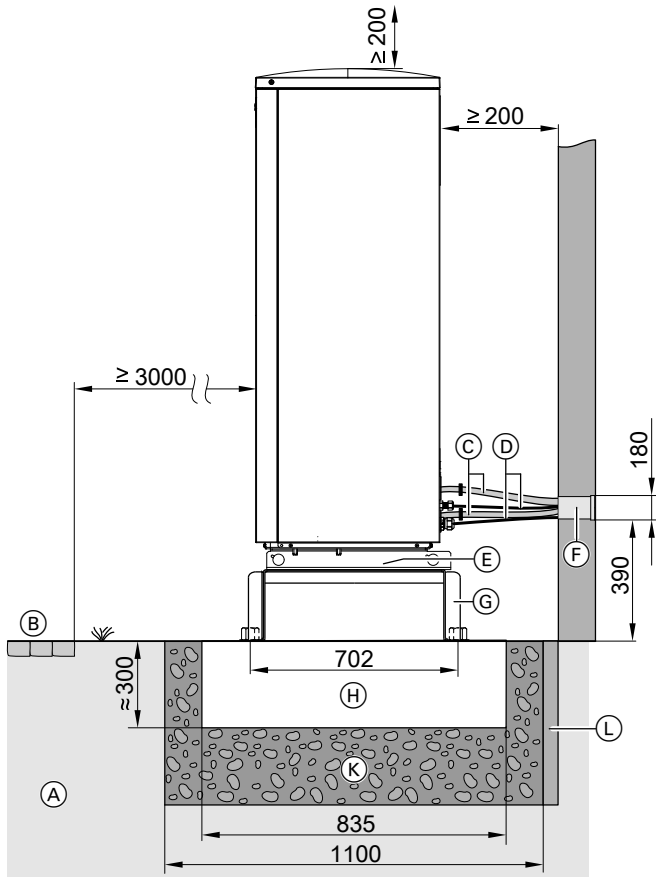

Fig. 11

- (A) Ground
- (B) Pathway, patio
- (C) Hydraulic connection lines, indoor/outdoor unit
- (D) Indoor/outdoor unit Modbus cable and outdoor unit power cable:  
Route the cables free of stress.
- (E) Openings in the base plate for free drainage of condensate:  
Do not seal the openings.
- (F) Connection set, wall mounting (accessories)
- (G) Support for floorstanding installation (accessories)
- (H) Foundation strip
- (K) Frost protection for foundations (compacted crushed stone, e.g. 0 to 32/56 mm); thickness of layer subject to local requirements and building regulations
- (L) Flexible separating layer between the foundations and the building

**Note**

Provide thermal insulation of sufficient thickness on the pipework to the outdoor air: See table on page 14.

**Floorstanding installation with support and design casing: Line entry above ground level**

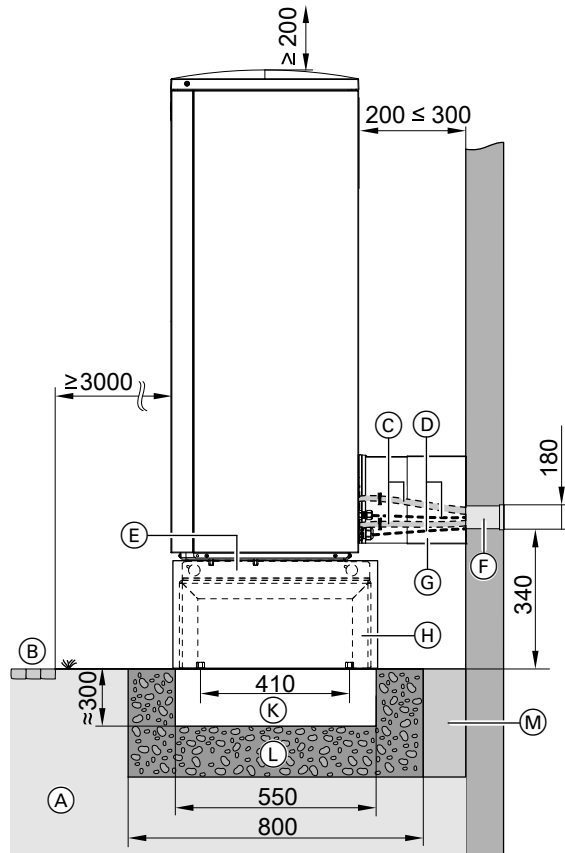

Fig. 12

- (A) Ground
- (B) Pathway, patio
- (C) Hydraulic connection lines, indoor/outdoor unit
- (D) Indoor/outdoor unit Modbus cable and outdoor unit power cable:  
Route the cables free of stress.
- (E) Openings in the base plate for free drainage of condensate:  
Never seal the openings.
- (F) Connection set, wall mounting (accessories)
- (G) Design casing wall connection (accessories)
- (H) Design casing with support (accessories)
- (K) Foundation strip
- (L) Frost protection for foundations (compacted crushed stone, e.g. 0 to 32/56 mm); thickness of layer subject to local requirements and building regulations
- (M) Flexible separating layer between the foundations and the building

**Note**

Provide thermal insulation of sufficient thickness on the pipework to the outdoor air: See table on page 14.

Installing the outdoor unit (cont.)

Floorstanding installation with support, line entry below ground level

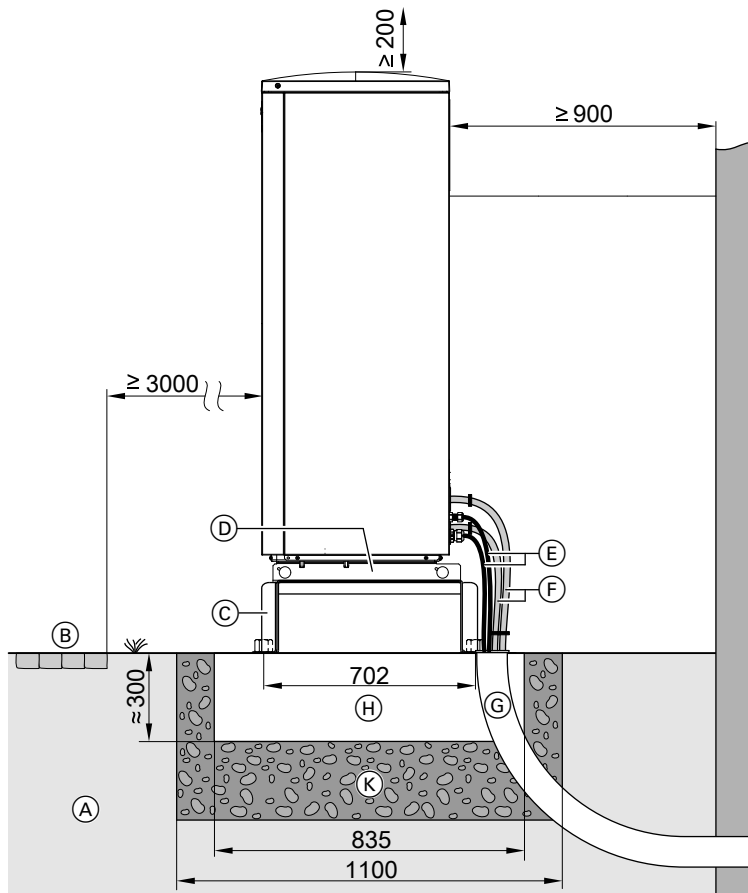

Fig. 13

- (A) Ground
- (B) Pathway, patio
- (C) Support for floorstanding installation (accessories)
- (D) Openings in the base plate for free drainage of condensate:  
Never seal the openings.
- (E) Indoor/outdoor unit Modbus cable and outdoor unit power cable:  
Route the cables so they are not stressed.
- (F) Floorstanding installation connection set (accessories)
- (G) Hydraulic connection set (accessories)
- (H) Foundation strip
- (K) Frost protection for foundations (compacted crushed stone, e.g. 0 to 32/56 mm); thickness of layer subject to local requirements and building regulations

**Note**

Provide thermal insulation of sufficient thickness on the pipework to the outdoor air: See table on page 14.

Floorstanding installation with support and design casing: Line entry below ground level

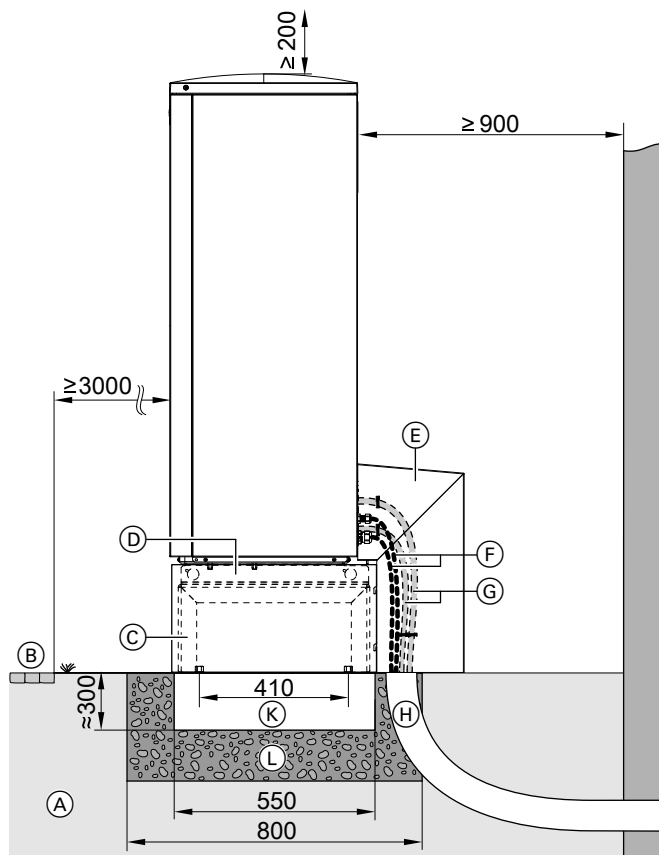

Fig. 14

- Ⓐ Ground
- Ⓑ Pathway, patio
- Ⓒ Design casing with support (accessories)
- Ⓓ Openings in the base plate for free drainage of condensate:  
Never seal the openings.
- Ⓔ Design casing floor connection (accessories)
- Ⓕ Indoor/outdoor unit Modbus cable and outdoor unit power cable:  
Route the cables free of stress.
- Ⓖ Connection set, floorstanding installation (accessories)
- Ⓗ Hydraulic connection set (accessories)
- Ⓚ Foundation strip
- Ⓛ Frost protection for foundations (compacted crushed stone, e.g. 0 to 32/56 mm); thickness of layer subject to local requirements and building regulations

**Note**

Provide thermal insulation of sufficient thickness on the pipework to the outdoor air: See table on page 14.

## Installing the outdoor unit (cont.)

### Installing an outdoor unit on foundations

#### Note

We recommend letting condensate drain away **freely** (no condensate pipe).

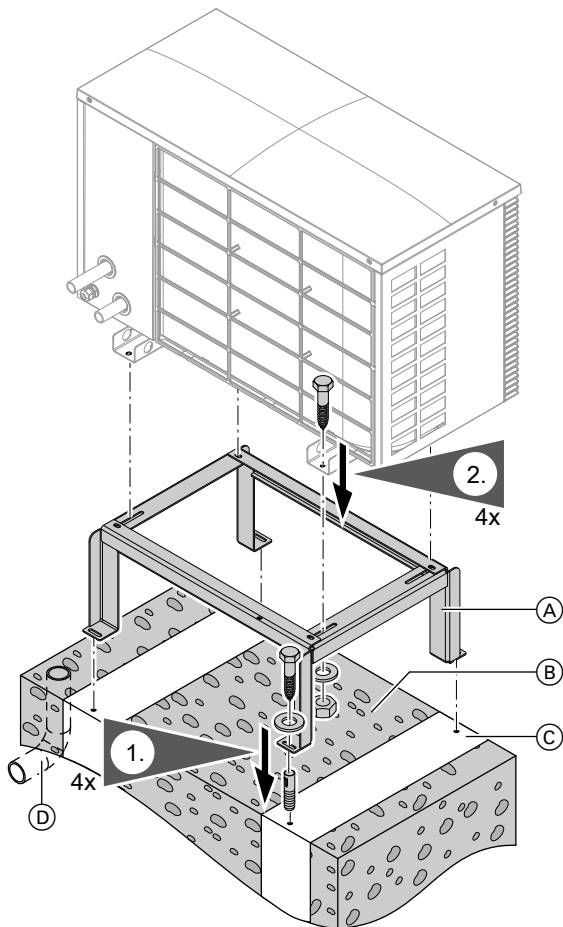

Fig. 15

- (A) Support for floorstanding installation (accessories)
- (B) Gravel bed as condensate soakaway
- (C) Concrete foundations (see technical guide)
- (D) Only for line entry below ground level: Hydraulic connection set (accessories)

### Wall mounting

Installation should **only** be performed with the bracket sets for wall mounting (accessories).



Separate installation instructions

Wall mounting with bracket set for wall mounting

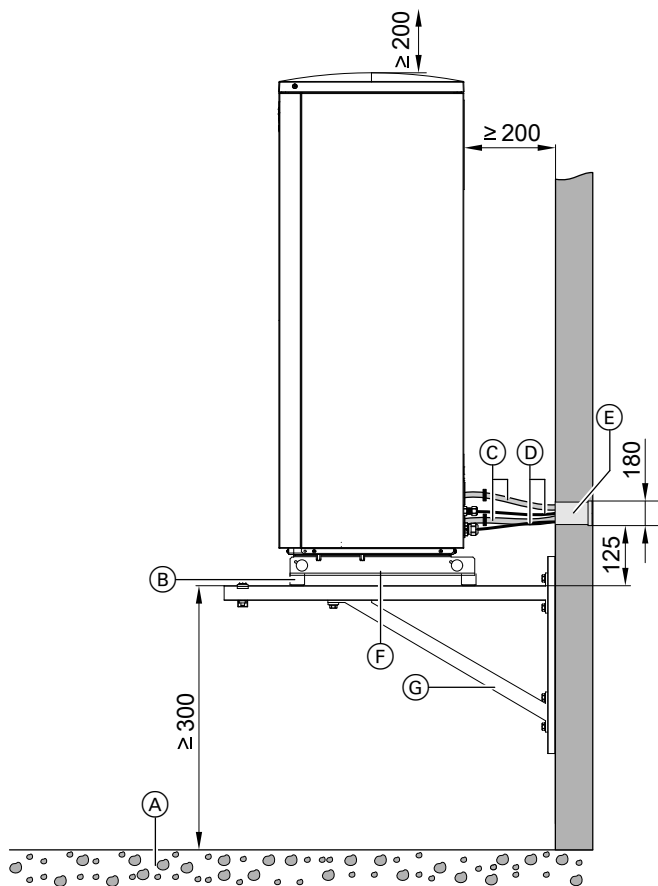

Fig. 16

- (A) Gravel bed as condensate soakaway
- (B) Vibration isolation (standard delivery of the support)
- (C) Hydraulic connection lines, indoor/outdoor unit
- (D) Indoor/outdoor unit Modbus cable and outdoor unit power cable:  
Route the cables free of stress.
- (E) Connection set, wall mounting (accessories)
- (F) Openings in the base plate for free drainage of condensate:  
Do not seal the openings.
- (G) Bracket for wall mounting (accessories)

**Note**

Provide thermal insulation of sufficient thickness on the pipework to the outdoor air: See table on page 14.

Wall mounting with bracket set for wall mounting and design casing

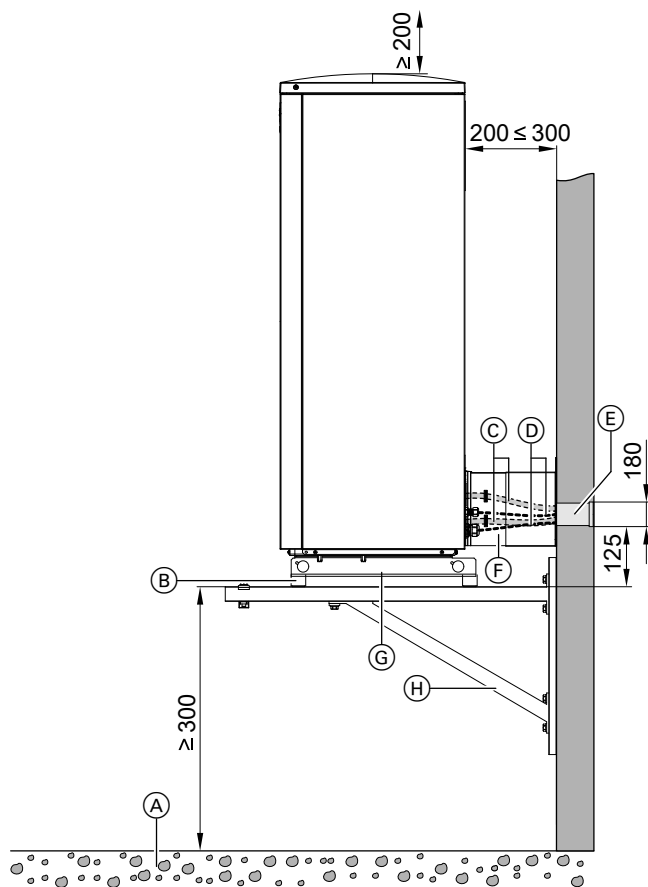

Fig. 17

- (A) Gravel bed as condensate soakaway
- (B) Vibration isolation (standard delivery of the support)
- (C) Hydraulic connection lines, indoor/outdoor unit
- (D) Indoor/outdoor unit Modbus cable and outdoor unit power cable:  
Route the cables free of stress.
- (E) Connection set, wall mounting (accessories)
- (F) Design casing wall connection (accessories)
- (G) Openings in the base plate for free drainage of condensate:  
Never seal the openings.
- (H) Bracket for wall mounting (accessories)

**Note**

Provide thermal insulation of sufficient thickness on the pipework to the outdoor air: See table on page 14.

Installing the outdoor unit (cont.)

Opening the wiring chamber

Outdoor unit with 1 fan

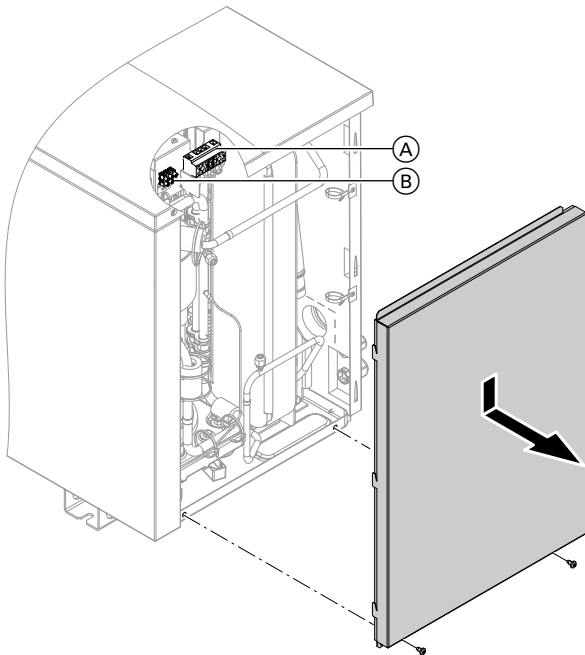

Fig. 18

- (A) Compressor power supply
- (B) Modbus connection (connection to the indoor unit)

Outdoor unit with 2 fans

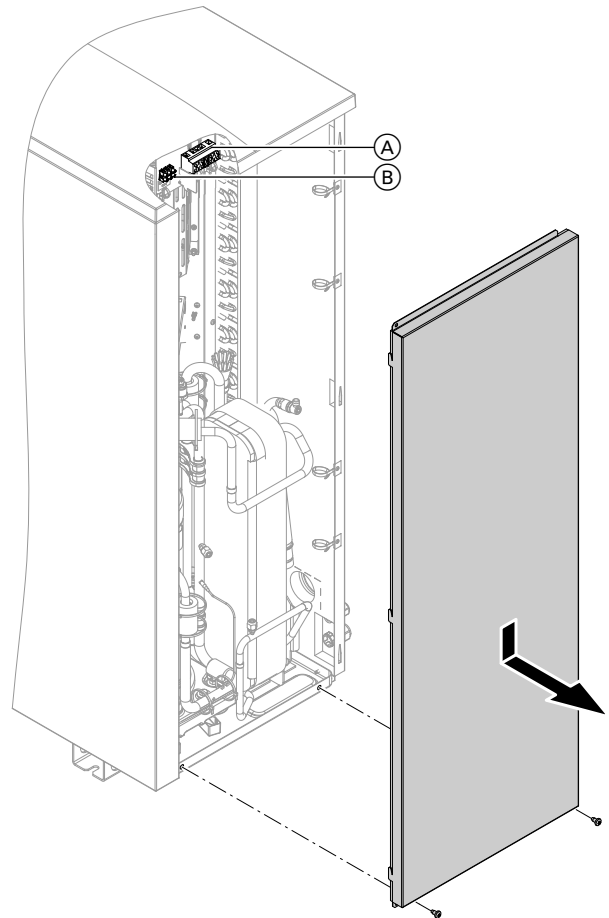

Fig. 19

- (A) Compressor power supply
- (B) Modbus connection (connection to the indoor unit)



Removing the transport brackets

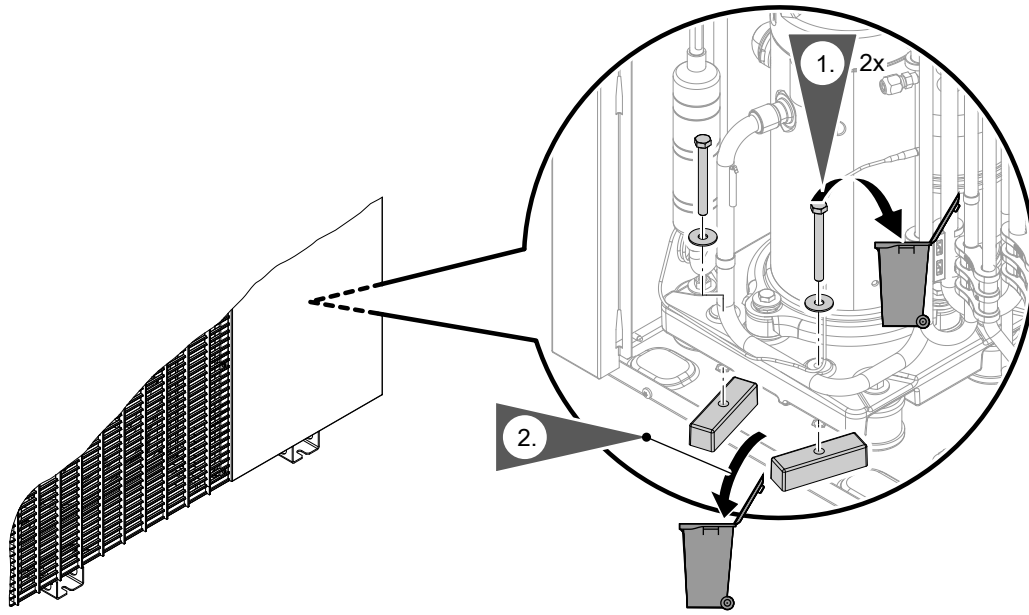

Fig. 20

## Installing the outdoor unit (cont.)

## Connecting the supplied hoses

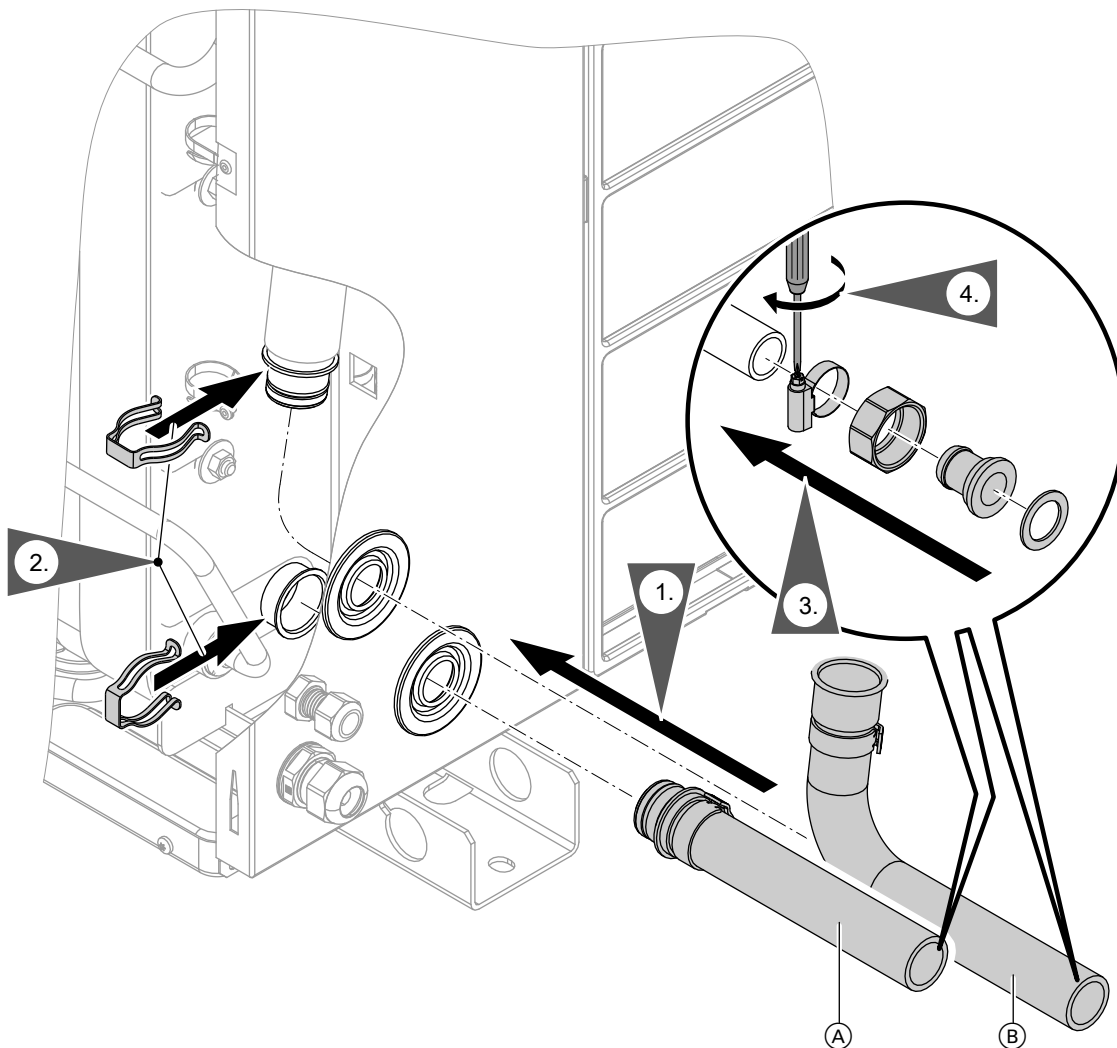

Fig. 21

- (A) Outdoor unit return (heating water inlet)
- (B) Outdoor unit flow (heating water outlet)

## Installing the indoor unit

## Transport

**Please note**

Impacts, compression and tensile loads can cause damage to the outside panels of the appliance.

**Never** apply loads/weight to the top, front or side panels of the appliance.

### Installing the indoor unit (cont.)

#### Requirements for the installation room

- !** **Please note**  
An unfavourable indoor environment can lead to malfunctions and appliance damage.
- The installation room must be dry and free from the risk of frost.
  - Ensure ambient temperatures between 0 and 35 °C.
  - Max. 70 % relative humidity (corresponding to an absolute humidity of approx. 25 g water vapour/kg of dry air at 35 °C)



**Danger**  
Dust, gases and vapours can be damaging to health and trigger explosions.  
Prevent dust, gases and vapours in the installation room.

#### Minimum clearances

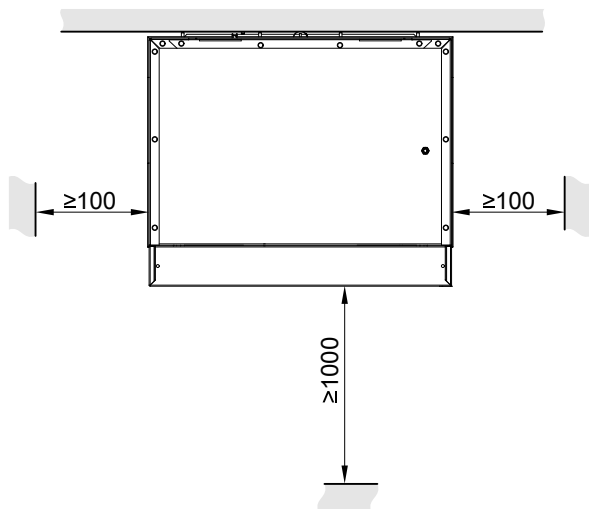

Fig. 22

#### Fitting the indoor unit to the wall

**Note**

Take account of the weight of the indoor unit: See "Specification".  
Check the condition of the wall where the boiler is to be installed. Use fixing materials with sufficient load bearing capacity.

Installing the indoor unit (cont.)

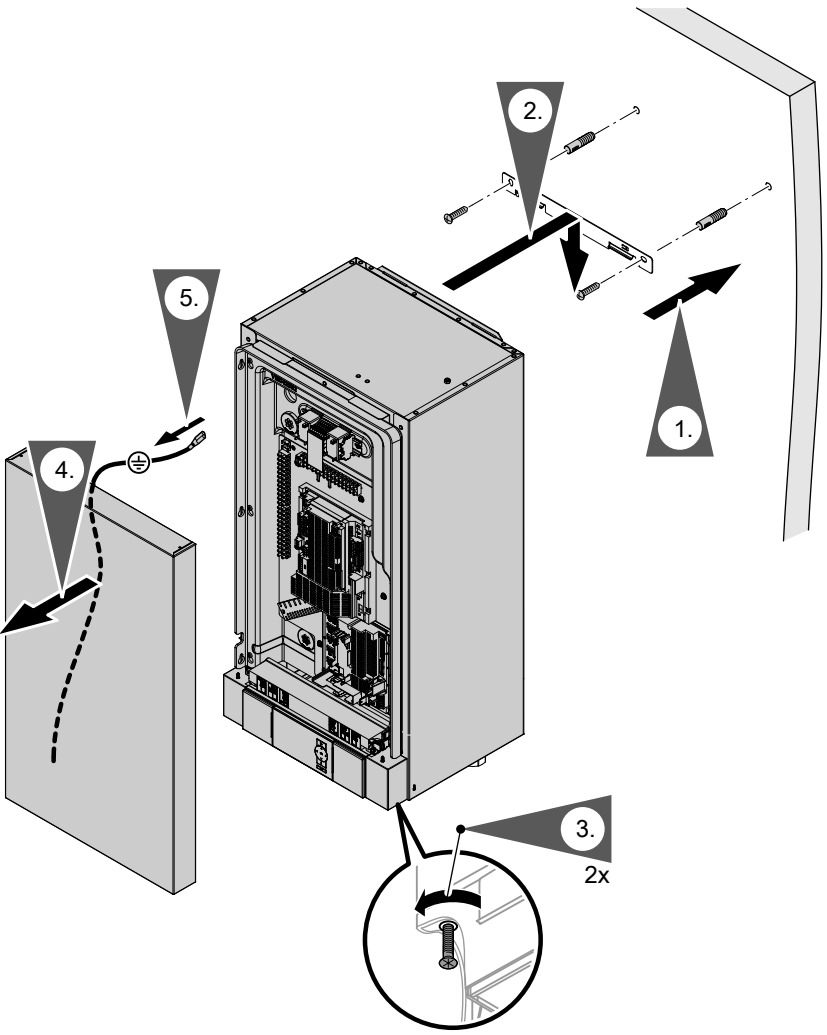

Fig. 23

## Connecting the secondary circuit

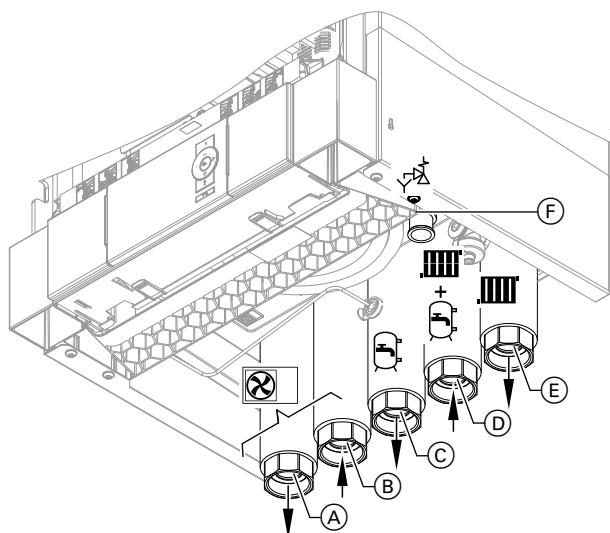

Fig. 24

- (A) Heating water **to** outdoor unit: G 1¼ (union nut DN 32, female thread)
- (B) Heating water **from** outdoor unit G 1¼ (union nut DN 32, female thread)
- (C) DHW cylinder flow (heating water side): G 1¼ (union nut DN 32, female thread)
- (D) Heating water return and DHW cylinder return: G 1¼ (union nut DN 32, female thread)
- (E) Heating water flow: G 1¼ (union nut DN 32, female thread)
- (F) Safety valve drain hose

1. Equip the secondary circuit on site with an expansion vessel and safety assembly (in accordance with DIN 4757). Fit the safety assembly to the on-site line in the heating water return.
2. Connect all the hydraulic lines to the indoor unit (secondary circuit and connection lines from the outdoor unit).

### Connections to the outdoor unit

- Max. torque for flow and return to the outdoor unit: 50 Nm
- Connection sets (accessories) are available for hydraulic connection to the outdoor unit.



### Please note

Mechanically loaded hydraulic connections lead to leaks, vibrations and appliance damage. Connect on-site lines so that they are free of load and torque stress.

3. Thoroughly flush the heating system.
4. Check the internal and on-site hydraulic connections for leaks.



### Please note

Leaking hydraulic connections lead to appliance damage. In the event of leaks, drain off liquid via the drain valve. Check the seating of seal rings. **Always** replace displaced seal rings.

### Note

The secondary circuit air vent valve is located in the indoor unit. To vent, connect the hose to the secondary circuit air vent valve. Route the hose outwards.

Observe additional information regarding filling and venting: See page 62.

5. Thermally insulate lines inside the building. For heat pumps with a cooling function, use thermal and vapour diffusion-proof insulation.

Pipework internal Ø	Min. thickness of thermal insulation layer with $\lambda = 0.035 \text{ W/(m}\cdot\text{K)}$
≤ 22 mm	40 mm
> 22 mm	60 mm

$\lambda$  Thermal conductivity

6. Connect the drain hose of the safety valve  to the drain network with a fall and a pipe vent.

### Note

- In underfloor heating circuits, install a temperature limiter to restrict the maximum temperature for underfloor heating systems: See page 38.
- Ensure the minimum flow rate, e.g. by means of an overflow valve: See "Specification" on page 101.

## Only type AWO(-M)-E-AC 201.A: Connecting the cooling circuit

### Contact humidistat

For area cooling systems (e.g. underfloor heating circuit, chilled ceiling), a contact humidistat (accessories) is required.

Requirements for the contact humidistat:

- Electrical connection, subject to the type of contact humidistat:
  - 24 V $\overline{=}$  (recommendation):  
Connection to F11 on the controller and sensor PCB
  - 230 V $\sim$ , 0.5 A:  
Connection to X3.8/3.9 on the luster terminals
- Installation inside the room to be cooled at the cooling water flow (remove thermal insulation if required)
- If several rooms with different relative humidity levels are part of the cooling circuit, fit and connect several contact humidistats in series:  
Design the switching contacts as N/C contacts.

## Electrical connection

### Preparing the electrical connections

#### Cables

- For cable lengths and cable cross-sections: See the following tables.
- For accessories:  
Cables with the required number of cores for external connections.  
Prepare an on-site distribution box.

#### Note

Make all connections on the control unit panel (see page 36) with **flexible** cables to ensure that it can be placed in the service position (see page 79).



#### Danger

Damaged wiring insulation wiring can lead to serious injury from electrical current and result in appliance damage.  
Route cables so that they cannot touch very hot, vibrating or sharp-edged components.



#### Danger

Incorrect wiring can lead to serious injury from electrical current and result in appliance damage.

Take the following measures to prevent drifting of wires into the adjacent voltage area:

- Route LV leads < 42 V separately from cables > 42 V/230 V $\sim$ /400 V $\sim$  and secure with cable ties.
- Strip as little of the insulation as possible, directly before the terminals. Bundle cables/leads close to the corresponding terminals.
- If 2 components are connected to the same terminal, press both cores together in a **single** wire ferrule.

### Cable lengths in the indoor/outdoor unit

Cables	Indoor unit	Outdoor unit with	
		1 fan	2 fans
<b>Power cables</b>	■ Heat pump control unit, 230 V $\sim$	1.2 m	—
	■ Compressor, 230 V $\sim$ /400 V $\sim$	—	1.2 m
<b>Other connecting cables</b>	■ 230 V $\sim$ , e.g. for circulation pumps	1.2 m	—
	■ < 42 V, e.g. for sensors	0.8 m	—
<b>Connecting cable for indoor/outdoor unit</b> (accessories, 15 m or 30 m long)	■ Modbus	0.8 m	1.2 m

**Electrical connection** (cont.)**Recommended flexible power cables****Indoor unit**

Power supply	Cable	Max. cable length
Heat pump control unit 230 V~	▪ Without power-OFF	3 x 1.5 mm <sup>2</sup>
	▪ With power-OFF	5 x 1.5 mm <sup>2</sup>
Instantaneous heating water heater	▪ 400 V~	5 x 2.5 mm <sup>2</sup> 25 m
	▪ 230 V~	7 x 2.5 mm <sup>2</sup> 25 m

**Outdoor units****Heat pumps with outdoor unit 230 V**

Types	Cable	Max. cable length	Max. fuse rating
201.A04	3 x 2.5 mm <sup>2</sup>	29 m	B16A
201.A06	3 x 2.5 mm <sup>2</sup>	29 m	B16A
201.A08	3 x 2.5 mm <sup>2</sup>	29 m	B16A
201.A10	3 x 2.5 mm <sup>2</sup>	20 m	B25A
	<b>Or</b> 3 x 4.0 mm <sup>2</sup>	32 m	
201.A13	3 x 2.5 mm <sup>2</sup>	20 m	B25A
	<b>Or</b> 3 x 4.0 mm <sup>2</sup>	32 m	
201.A16	3 x 2.5 mm <sup>2</sup>	20 m	B25A
	<b>Or</b> 3 x 4.0 mm <sup>2</sup>	32 m	

**Heat pumps with outdoor unit 400 V**

Types	Cable	Max. cable length	Max. fuse rating
201.A10	5 x 2.5 mm <sup>2</sup>	30 m	B16 A
201.A13	5 x 2.5 mm <sup>2</sup>	30 m	B16 A
201.A16	5 x 2.5 mm <sup>2</sup>	30 m	B16 A



**Electrical connection** (cont.)

**Indoor unit: Routing cables to the wiring chamber**

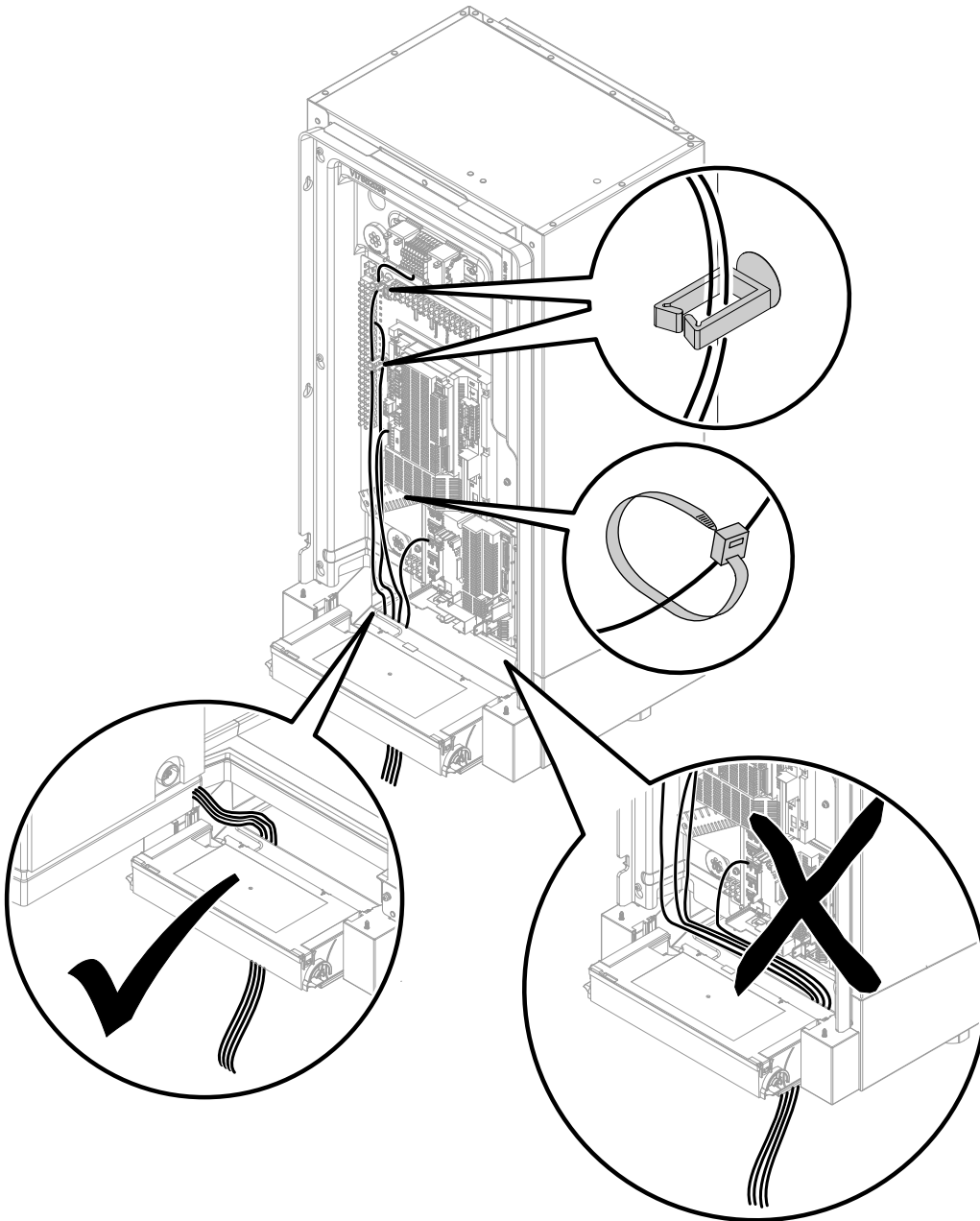

Fig. 25

Connecting the Vitoconnect (accessories)

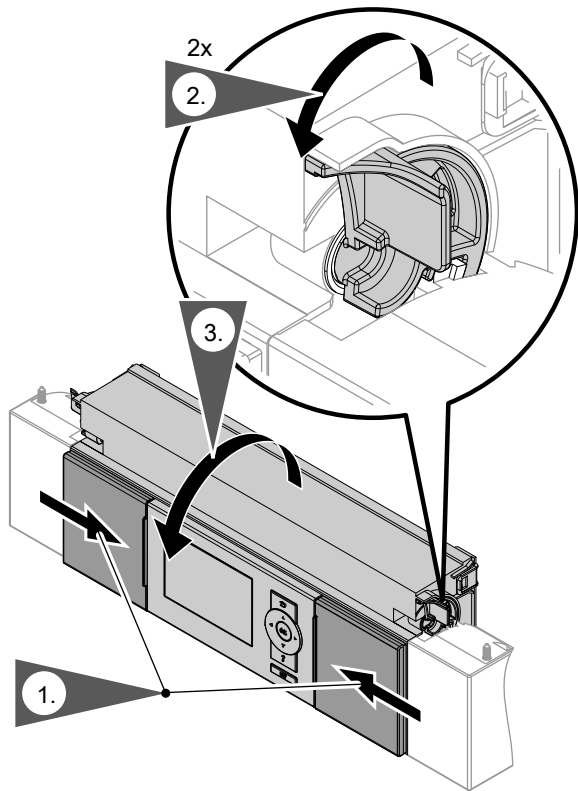

Fig. 26

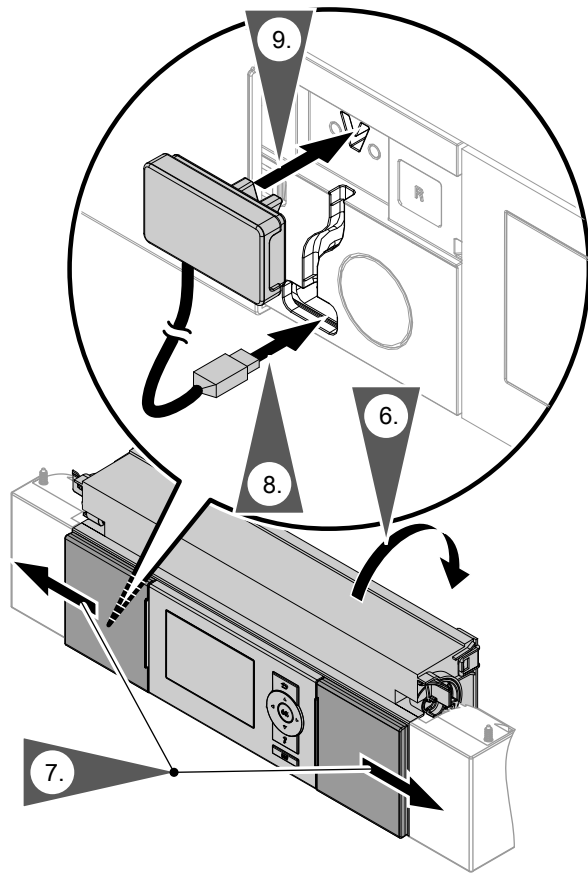

Fig. 28

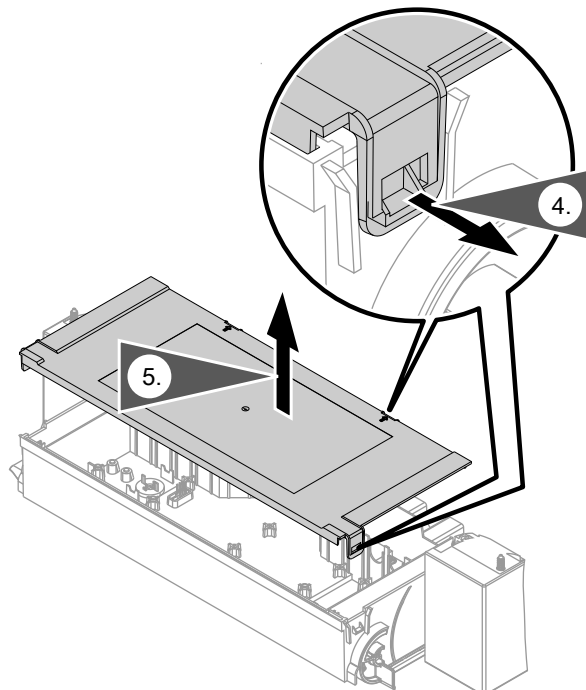

Fig. 27

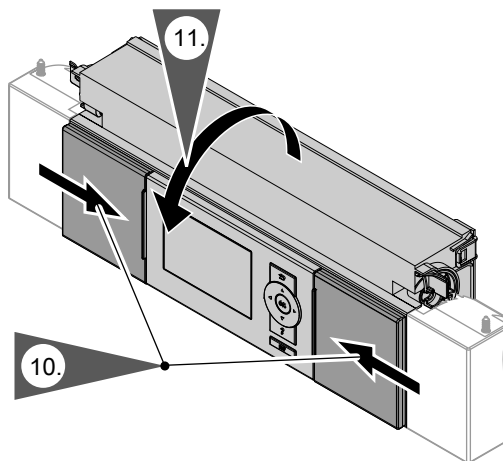

Fig. 29

Electrical connection (cont.)

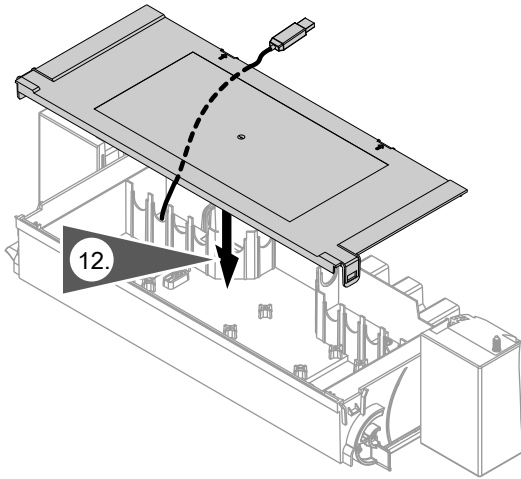

Fig. 30

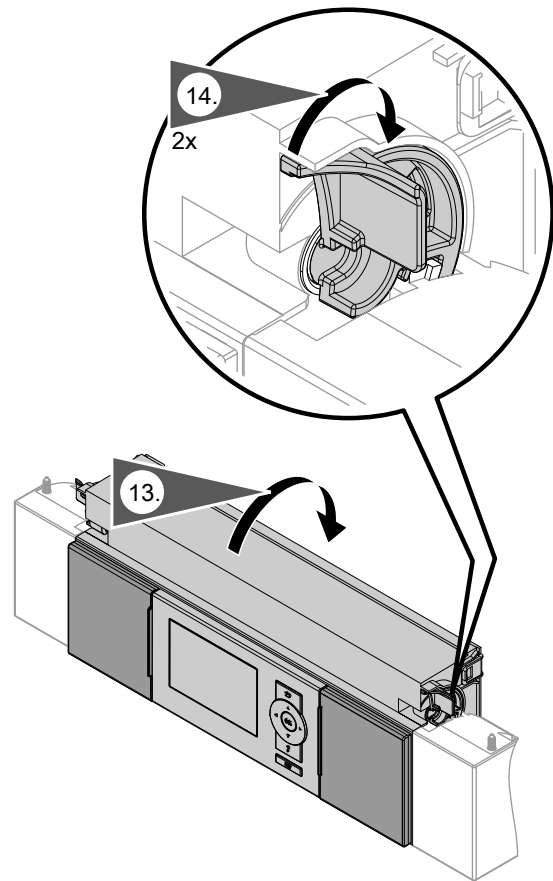

Fig. 31



**Electrical connection** (cont.)



- Ⓕ Controller and sensor PCB: See page 44.
- Ⓖ Connection for Modbus cable to the outdoor unit

**Indoor unit: Main PCB (230 V~ components)****Information regarding the connection values**

- The specified output is the recommended connected load.
- Total output of all components connected directly to the heat pump control unit (e.g. pumps, valves, message facilities, contactors): **Max. 1000 W**  
If the total output is < 1000 W, the individual rating of a component (e.g. pump, valve, message facility, contactor) can be greater than specified. However, the breaking capacity of the relevant relay must not be exceeded.
- The specified current indicates the max. switching current of the switching contact. Observe total current of 5 A.

Set the required parameters during commissioning:  
See page 65 onwards.

**Plug** 211



Terminals	Function	Explanation
211.2 	Secondary pump	<p>Supply values</p> <ul style="list-style-type: none"> <li>▪ Output: 140 W</li> <li>▪ Voltage: 230 V~</li> <li>▪ Max. switching current: 4(2) A</li> </ul> <p>▪ In systems without a heating water buffer cylinder, no other heating circuit pump is required: See terminal 212.2.</p> <p>▪ Connect a temperature limiter in series to restrict the maximum temperature of underfloor heating circuit (if installed).</p> <p>Secondary pump is connected at the factory. Connect the temperature limiter on site.</p>
211.3 	Control of instantaneous heating water heater, stage 1  <b>Note</b> <i>For heat pumps with integral instantaneous heating water heater connected at the factory</i>	<p>Supply values</p> <ul style="list-style-type: none"> <li>▪ Output: 10 W</li> <li>▪ Voltage: 230 V~</li> <li>▪ Max. switching current: 4(2) A</li> </ul>

**Electrical connection** (cont.)

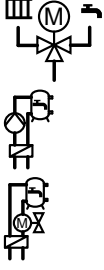
**Plug 211**

Terminals	Function	Explanation
211.4 	<ul style="list-style-type: none"> <li>3-way diverter valve "central heating/DHW heating"</li> <li>Cylinder loading pump</li> <li>2-way shut-off valve</li> </ul>	<p>Supply values</p> <ul style="list-style-type: none"> <li>Output: 130 W</li> <li>Voltage: 230 V~</li> <li>Max. switching current: 4(2) A</li> </ul> <p><b>Note</b> Depending on the system design, not all components are available.</p>
211.5 * AC	Only for heat pumps with a cooling function: 3-way diverter valves for heating water buffer cylinder bypass in cooling mode	<p>Connect the 3-way diverter valves in parallel.</p> <p>Supply values</p> <ul style="list-style-type: none"> <li>Output: 10 W</li> <li>Voltage: 230 V~</li> <li>Max. switching current: 4(2) A</li> </ul>

**Plug 212**

Clamps	Function	Explanation
212.2 	Heating circuit pump for heating circuit without mixer A1/HC1	<ul style="list-style-type: none"> <li>This pump is connected in addition to the secondary pump if a heating water buffer cylinder is installed.</li> <li>Connect the temperature limiter to restrict the maximum temperature for underfloor heating systems (if installed) in series.</li> </ul> <p>Connection values</p> <ul style="list-style-type: none"> <li>Output: 100 W</li> <li>Voltage: 230 V~</li> <li>Max. switching current: 4(2) A</li> </ul>
212.3 	DHW circulation pump	<p>Connection values</p> <ul style="list-style-type: none"> <li>Output: 50 W</li> <li>Voltage: 230 V~</li> <li>Max. switching current: 4(2) A</li> </ul>
212.4 	3-way diverter valve for heating water buffer cylinder bypass or heat pump in the case of dual alternative mode	<p>Connection values</p> <ul style="list-style-type: none"> <li>Output: 130 W</li> <li>Voltage: 230 V~</li> <li>Max. switching current: 4(2) A</li> </ul>

**Connecting a temperature limiter as a maximum temperature limiter for underfloor heating**

Connecting a general temperature limiter (B)

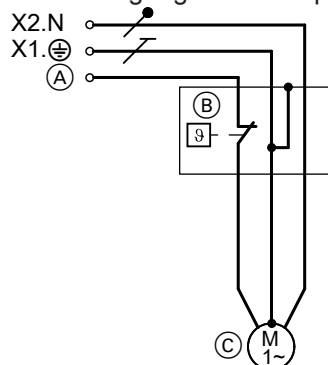

Fig. 33

Connecting the temperature limiter, part no. 7151728, 7151729 (B)

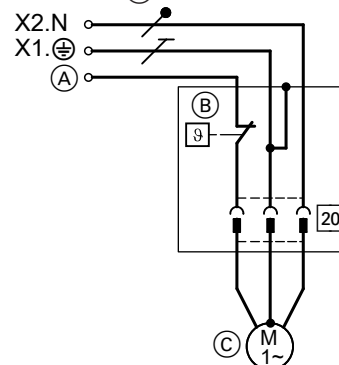

Fig. 34

**Electrical connection** (cont.)

	Connection (A) to control unit	Circulation pump (C)
<b>Heating circuit without mixer A1/HC1</b>		
▪ Without heating water buffer cylinder	211.2	Secondary pump
▪ With heating water buffer cylinder	212.2	Heating circuit pump A1/HC1
<b>Heating circuit with mixer M2/HC2</b>		
	225.1	Heating circuit pump M2/HC2

Connecting the temperature limiter, part no. 7151728, 7151729 (B) to the mixer extension kit

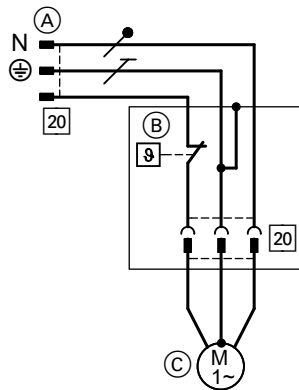





Fig. 35





- (A) Connect plug 20 to the extension kit.
- (B) Temperature limiter
- (C) Heating circuit pump M3/HC3

**Plug 214**

Terminals	Function	Explanation
214.1  M2	External hook-up, heating/cooling circuits: Central heating demand, heating circuit M2/HC2	230 V~ digital input: ▪ 230 V~: Central heating demand for heating circuit M2/HC2 active ▪ 0 V: No demand ▪ Breaking capacity 230 V, 0.15 A
214.2  M2	External hook-up, heating/cooling circuits: Central cooling demand, heating circuit M2/HC2	230 V~ digital input: ▪ 230 V~: Room cooling demand for heating circuit M2/HC2 active ▪ 0 V: No demand ▪ Breaking capacity 230 V, 0.15 A
214.3  M3	External hook-up, heating/cooling circuits: Central heating demand, heating circuit M3/HC3	230 V~ digital input: ▪ 230 V~: Room heating demand for heating circuit M3/HC3 active ▪ 0 V: No demand ▪ Breaking capacity 230 V, 0.15 A
214.4  M3	External hook-up, heating/cooling circuits: Central cooling demand, heating circuit M3/HC3	230 V~ digital input: ▪ 230 V~: Room cooling demand for heating circuit M3/HC3 active ▪ 0 V: No demand ▪ Breaking capacity 230 V, 0.15 A

**Electrical connection** (cont.)

**Plug** 216

Terminals	Function	Explanation
216.1  A1  	External hook-up, heating/cooling circuits: Central heating demand, heating circuit A1/HC1 <b>Or</b> Smart Grid: Floating contact 1	230 V~ digital input: <ul style="list-style-type: none"> <li>▪ 230 V~: Central heating demand for heating circuit A1/HC1 active</li> <li>▪ 0 V: No demand</li> <li>▪ Breaking capacity 230 V, 2 mA</li> </ul> 230 V~ digital input: <ul style="list-style-type: none"> <li>▪ 230 V~: Contact active</li> <li>▪ 0 V: Contact not active</li> <li>▪ Breaking capacity 230 V, 2 mA</li> </ul>
216.2  A1	External hook-up, heating/cooling circuits: Room cooling demand, heating circuit A1/HC1	230 V~ digital input: <ul style="list-style-type: none"> <li>▪ 230 V~: Room cooling demand for heating circuit A1/HC1 active</li> <li>▪ 0 V: No demand</li> <li>▪ Breaking capacity 230 V, 0.15 A</li> </ul>
216.4 	Smart Grid: Floating contact 2	230 V~ digital input: <ul style="list-style-type: none"> <li>▪ 230 V~: Contact active</li> <li>▪ 0 V: Contact not active</li> <li>▪ Breaking capacity 230 V, 2 mA</li> </ul>

**Note**

If external hook-up for heating/cooling circuits is connected and selected, Smart Grid can be connected to the EA1 extension (accessories) ("**Enable Smart Grid 7E80**" on "1").

**Indoor unit: Expansion PCB on main PCB (230 V~ components)**

**Information regarding connection values**





- The specified output is the recommended connected load.
- The total output of all components connected directly to the heat pump control unit (e.g. pumps, valves, message facilities, contactors) must not exceed 1000 W.  
If the total output is  $\leq 1000$  W, the individual rating of a component (e.g. pump, valve, message facility, contactor) can be greater than specified. However, the breaking capacity of the corresponding relay must not be exceeded.
- The specified current indicates the max. switching current of the switching contact. Observe total current 5 A.
- Safety LV is unsuitable for controlling external heat generators.

Set the required parameters during commissioning:  
See page 65 onwards.



**Electrical connection** (cont.)

**Plug 222**

Terminals	Function	Explanation
222.1  	Control of mixer motor for external heat generator Signal mixer CLOSE	Connection values: <ul style="list-style-type: none"> <li>Output: 10 W</li> <li>Voltage: 230 V~</li> <li>Max. switching current: 0.2(0.1) A</li> </ul>
222.2  	Control of mixer motor for external heat generator Signal mixer OPEN	Connection values: <ul style="list-style-type: none"> <li>Output: 10 W</li> <li>Voltage: 230 V~</li> <li>Max. switching current: 0.2(0.1) A</li> </ul>
222.3 222.4 	Control of external heat generators and 1 high limit safety cut-out each (on site, max. 70 °C), to switch off or switch between the following components:  Central heating: <ul style="list-style-type: none"> <li>Secondary pump, heat pump</li> <li>External heat generator</li> </ul> DHW reheating: <ul style="list-style-type: none"> <li>3-way diverter valve "Central heating/DHW heating"</li> </ul>	Floating contact  <b>Note</b> <ul style="list-style-type: none"> <li>The switching contact is a floating N/O contact that is closed when a heat demand is issued.</li> <li>Never route low voltage via this contact. For that, a relay must be fitted on site.</li> <li>The boiler water temperature sensor in the external heat generator (plug F20) must capture the average temperature of the external heat generator.</li> </ul> Connection values (contact load): <ul style="list-style-type: none"> <li>Voltage: 230 V~</li> <li>Max. switching current: 4(2) A</li> </ul> Connect the high limit safety cut-out:  Central heating <ul style="list-style-type: none"> <li>In series to the secondary pump (connection 211.2)</li> <li>In series for controlling external heat generators</li> </ul> DHW reheating <ul style="list-style-type: none"> <li>In series to the 3-way diverter valve "central heating/DHW heating" (connection 211.4)</li> </ul>

**High limit safety cut-out for heat pump in conjunction with external heat generator**

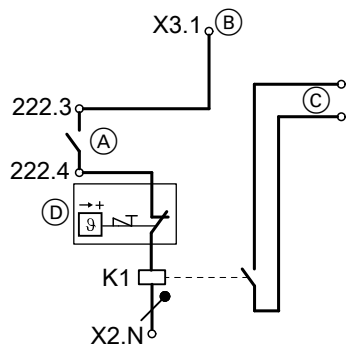



Fig. 36

- (A) Terminals on extension PCB
- (B) Connect jumper across X3.1 and 222.3.

- (C) Connection on external heat generator to terminals for "External demand"
- (D) High limit safety cut-out to protect the heat pump (max. 70 °C)
- K1 Relay
  - Sizing according to the external heat generator
  - Observe safety instructions.

**Electrical connection** (cont.)

**Plug** 224

Terminals	Function	Explanation
224.4 	Control of instantaneous heating water heater, stage 2  <b>Note</b> <i>For heat pumps with integral instantaneous heating water heater connected at the factory</i>	Connection values <ul style="list-style-type: none"> <li>▪ Output: 10 W</li> <li>▪ Voltage: 230 V~</li> <li>▪ Max. switching current: 4(2) A</li> </ul>
224.7 	Circulation pump for DHW reheating <b>or</b> Control of immersion heater	Connection values <ul style="list-style-type: none"> <li>▪ Output: 100 W</li> <li>▪ Voltage: 230 V~</li> <li>▪ Max. switching current: 4(2) A</li> </ul>

**Instantaneous heating water heater**

 **Type AWO(-M) 201.A: Accessory**  
Installation instructions, instantaneous heating water heater

**Control and power circuit of the instantaneous heating water heater**

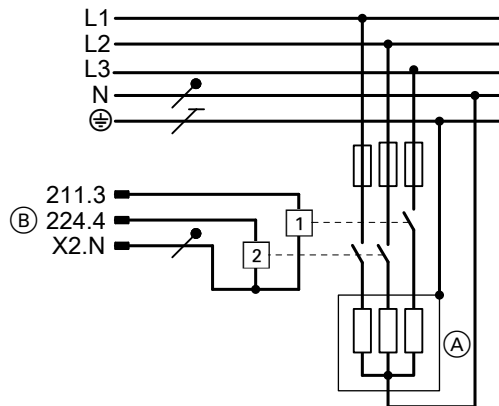

Fig. 37

- (A) Instantaneous heating water heater
- (B) Connection to the main PCB and expansion PCB  
211.3 stage 1  
224.4 stage 2

**Immersion heater EHE 400 V~**

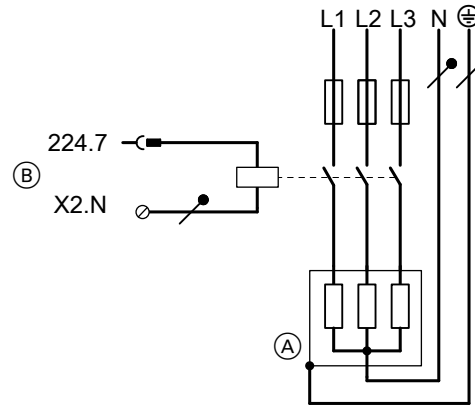

Fig. 38

- (A) Immersion heater EHE, power supply 3/N/PE  
400 V/50 Hz
- (B) Terminals of the heat pump control unit

**Immersion heater 230 V~ (on site)**

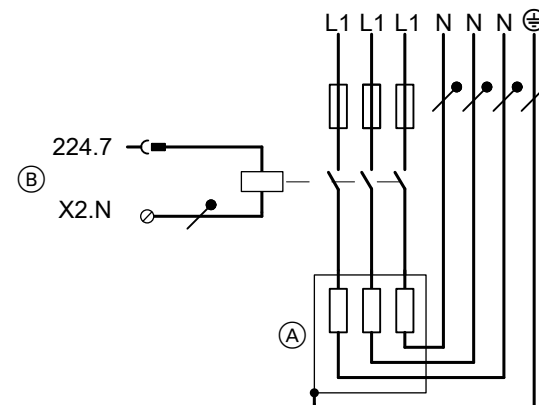









Fig. 39

- (A) Immersion heater, power supply 1/N/PE  
230 V/50 Hz
- (B) Terminals of the heat pump control unit

**Electrical connection** (cont.)

**Plug** 225

Terminals	Function	Explanation
225.1  M2 	Heating circuit pump of the heating circuit with mixer M2/HC2	Connect a temperature limiter to restrict the maximum temperature for underfloor heating circuits (if installed) in series.  Connection values: <ul style="list-style-type: none"> <li>▪ Output: 100 W</li> <li>▪ Voltage: 230 V~</li> <li>▪ Max. control current: 4(2) A</li> </ul>
225.2  M2   	Mixer motor control, heating circuit M2/HC2 Mixer CLOSE signal ▼	Connection values: <ul style="list-style-type: none"> <li>▪ Output: 10 W</li> <li>▪ Voltage: 230 V~</li> <li>▪ Max. control current: 0.2(0.1) A</li> </ul>
225.3  M2   	Mixer motor control, heating circuit M2/HC2 Mixer OPEN signal ▲	Connection values: <ul style="list-style-type: none"> <li>▪ Output: 10 W</li> <li>▪ Voltage: 230 V~</li> <li>▪ Max. control current: 0.2(0.1) A</li> </ul>

**Indoor unit: Luster terminals (signal and safety connections)**

Set the required parameters during commissioning:  
See page 65 onwards.

Terminals	Function	Explanation
X3.1	Switched phase	Via control unit ON/OFF switch  <b>Note</b> <i>Observe the total load 1000 W of all connected components.</i>
X3.6 X3.7  	Power-OFF (jumper fitted at the factory)	Requires floating <b>N/C</b> contact: <ul style="list-style-type: none"> <li>▪ Closed: Heat pump operational</li> <li>▪ Open: Heat pump shut down</li> <li>▪ Breaking capacity 230 V~, 0.15 A</li> </ul> Remove jumper when connecting. <b>Note</b> <ul style="list-style-type: none"> <li>▪ <i>No parameters need to be set</i></li> <li>▪ <i>The compressor is "forced" off as soon as the contact opens.</i></li> <li>▪ <i>The power-OFF signal switches off the power supply to the relevant component, subject to the power supply utility.</i></li> <li>▪ <i>For the instantaneous heating water heater, the stages to be switched off can be selected (parameter "<b>Output for instant. heating water heater at power-OFF 790A</b>").</i></li> <li>▪ <i>The power supply for the heat pump control unit (3 x 1.5 mm<sup>2</sup>) and the cable for the power-OFF signal can be combined in a single 5-core cable.</i></li> </ul>



**Electrical connection** (cont.)

Terminals	Function	Explanation
		<ul style="list-style-type: none"> <li>With heat pump cascades                             <ul style="list-style-type: none"> <li><b>Power supply without on-site load disconnect:</b> Only connect the power-OFF signal to the lead heat pump.</li> <li><b>Power supply with on-site load disconnect:</b> Connect the power-OFF signal to all heat pumps.</li> </ul> </li> <li>For further information regarding power-OFF: See chapter "Power supply".</li> </ul> <p><b>In connection with Smart Grid:</b> Do <b>not</b> connect the power-OFF signal. Do <b>not</b> remove jumper.</p>
X3.8 X3.9	<p>Only for heat pumps <b>with</b> a cooling function:</p> <ul style="list-style-type: none"> <li>Frost stat and/or Contact humidistat 230 V~</li> <li><b>Or</b> jumper</li> </ul> <p>For heat pumps <b>without</b> a cooling function:</p> <ul style="list-style-type: none"> <li>Jumper</li> </ul>	<p>Requires floating <b>N/C</b> contact:</p> <ul style="list-style-type: none"> <li>Closed: Safety chain has continuity</li> <li>Open: Safety chain interrupted; heat pump shut down</li> <li>Breaking capacity 230 V~, 0.15 A</li> </ul> <p>Connection:</p> <ul style="list-style-type: none"> <li>Connected in series if both safety components are installed</li> <li><b>Insert jumper if no safety components are installed.</b></li> </ul>
X40.L1	<p>Heat pump control unit power supply: Phase L1 X40.⊕ Earth conductor terminal X40.N Neutral conductor terminal</p>	Power supply 230 V~

**Indoor unit: Controller and sensor PCB (extra low voltage (ELV) connections)**

Set the required parameters during commissioning:  
See page 65 onwards.

**Sensors**

Plug	Sensor	Type
F0	Outside temperature sensor	NTC 10 kΩ
F4	Buffer temperature sensor	NTC 10 kΩ
F6 (X25.5/X25.6)	Cylinder temperature sensor, top	NTC 10 kΩ
F7 (X25.7/X25.8)	Cylinder temperature sensor, bottom	NTC 10 kΩ
F11	<p>Contact humidistat 24 V== <b>Or</b> jumper</p> <p><b>Note</b></p> <ul style="list-style-type: none"> <li>System with buffer cylinder for heating water/coolant: If cooling takes place over multiple heating/cooling circuits, provide a contact humidistat for each heating/cooling circuit. Connect multiple contact humidistats in series.</li> <li>If a 230 V~ contact humidistat (connection to X3.8/X3.9) is used for cooling, <b>insert a jumper</b>, otherwise the heat pump will not start (message "<b>CA Protectn device primry</b>").</li> </ul>	—
F12	Flow temperature sensor, heating circuit with mixer M2/HC2	NTC 10 kΩ

## Electrical connection (cont.)

Plug	Sensor	Type
F13	System flow temperature sensor (downstream of the buffer cylinder and mixer for external heat generator)	NTC 10 kΩ
F14	Flow temperature sensor, cooling circuit (without buffer cylinder, heating circuit without mixer A1/HC1 or separate cooling circuit SKK)	NTC 10 kΩ
F16	Room temperature sensor, cooling circuit <ul style="list-style-type: none"> <li>▪ Required for separate cooling circuit SKK</li> <li>▪ Recommended for heating/cooling circuit without mixer A1/HC1</li> </ul>	NTC 10 kΩ
F20	Boiler water temperature sensor, external heat generator	NTC 10 kΩ
F21	For heat pump cascades: Swimming pool flow temperature sensor	NTC 20 kΩ
F23	For heat pump cascades: Buffer outlet temperature sensor	NTC 10 kΩ
145	KM-BUS (wires interchangeable) Use the KM-BUS distributor (accessories) if several devices are connected.  KM-BUS subscribers (examples): <ul style="list-style-type: none"> <li>▪ Mixer extension kit for heating circuit M3/HC3</li> <li>▪ Remote control (set heating circuit allocation on the remote control)</li> <li>▪ EA1 extension, AM1 extension</li> </ul>	—
241	Modbus (do <b>not</b> interchange the wires) Connection for energy meter of photovoltaic system	—
J1	Jumper for Modbus terminator <ul style="list-style-type: none"> <li>☐ Terminator active (delivered condition)</li> <li>☐ Terminator not active</li> </ul>	—
X18	Modbus (do <b>not</b> interchange the wires) <ul style="list-style-type: none"> <li>▪ Connected at the factory: Modbus cable to the outdoor unit or</li> <li>▪ Modbus distributor (accessories) if additional devices are to be connected, e.g. Vitovent 300-F: See "Modbus distributor" installation instructions.</li> </ul>	—
X24	Connection for LON communication module (see "LON communication module" installation instructions)	—
X31	Coding card slot	—
193 A	PWM signal connection for heating circuit pump M2/HC2	—

## Swimming pool heating

**Note**

- Swimming pool heating is controlled via EA1 extension with KM BUS.
- With heat pump cascades, install the swimming pool flow temperature sensor downstream of the 3-way diverter valve for "Swimming pool" and connect it to terminal F21 on the controller and sensor PCB of the lead heat pump.
- Make connections to EA1 extension **only** in accordance with Fig. 40.
- A filter circuit pump **cannot** be controlled via the heat pump control unit.



Electrical connection (cont.)

Outdoor unit: Routing cables to the wiring chamber

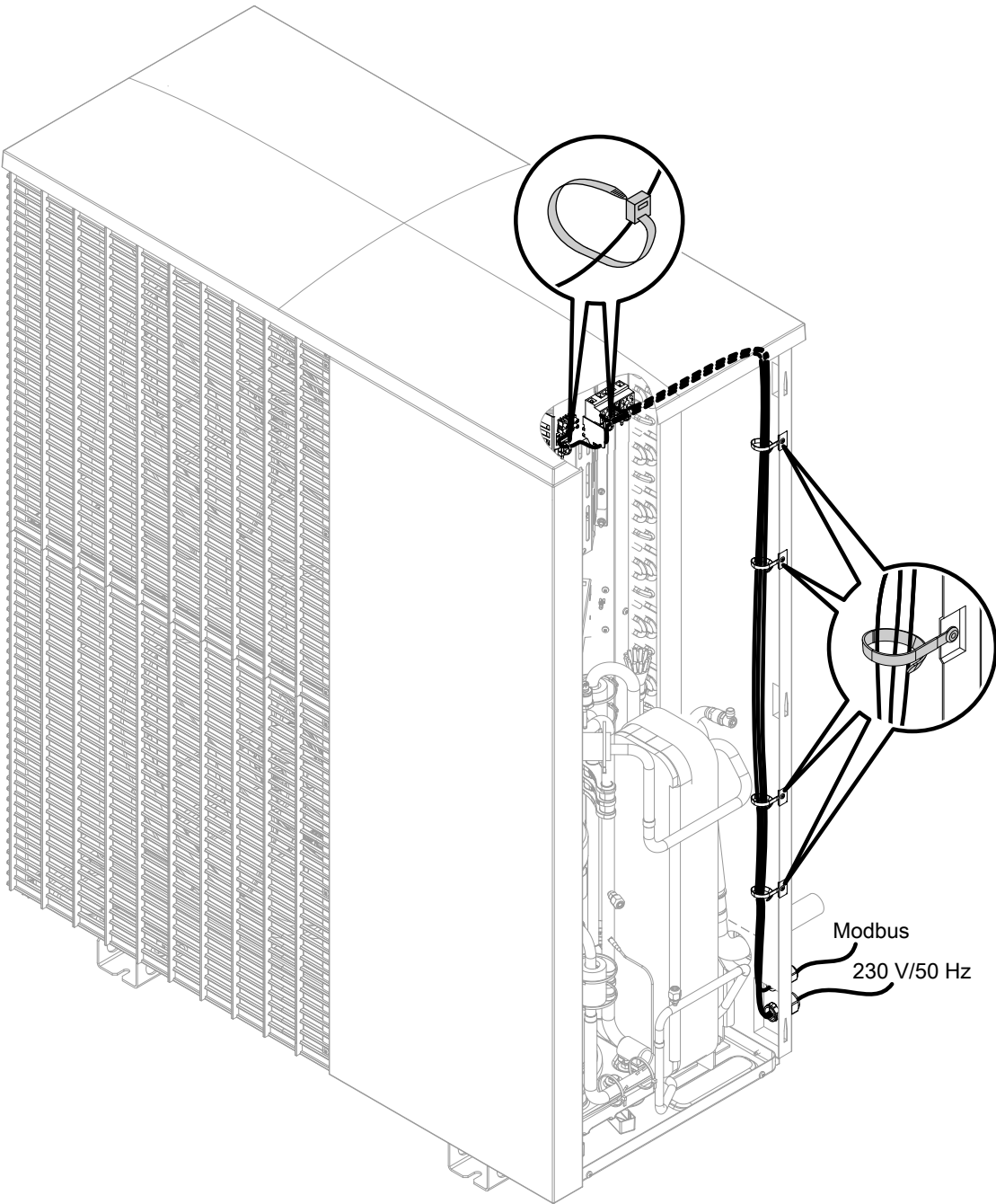

Fig. 41 Example: Type AWO-M-E-AC 201.A10



**Outdoor unit: Electrical terminal areas**

**Outdoor unit with 1 fan**

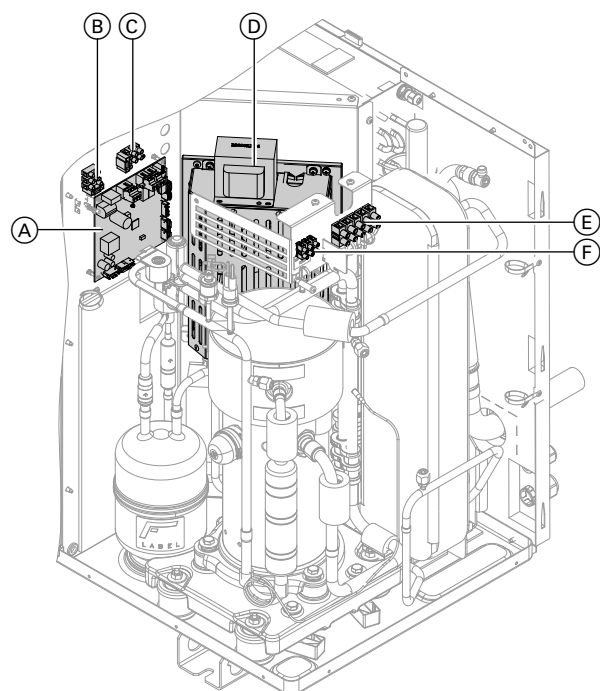

Fig. 42

- (A) EEV PCB (refrigerant circuit controller)
- (B) Fan fuse 6.3 A (slow)
- (C) Refrigerant circuit controller fuse 6.3 A (slow)
- (D) Inverter
- (E) Mains terminals 230 V/50 Hz:  
See page 53.
- (F) Terminal for Modbus cable between indoor/outdoor unit: See next chapter.

**Outdoor unit with 2 fans, 230 V~**

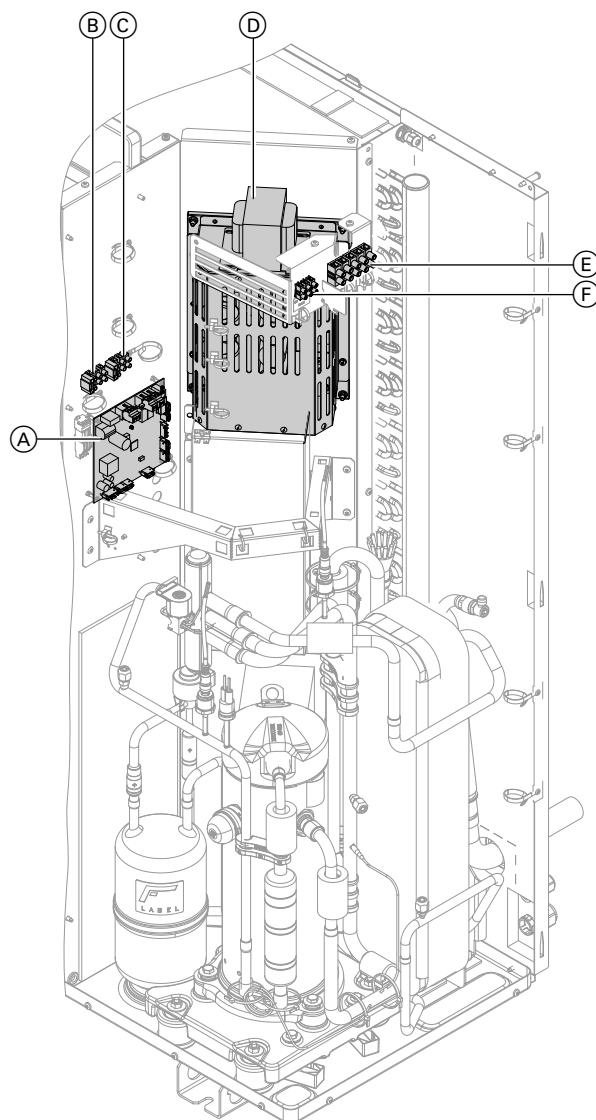
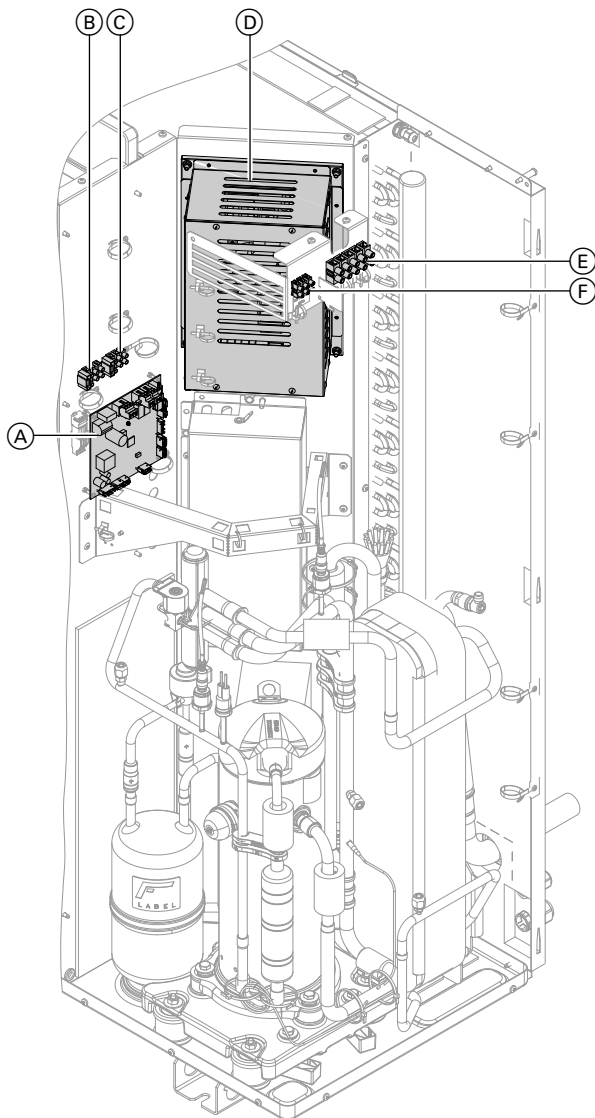

Fig. 43

- (A) EEV PCB (refrigerant circuit controller)
- (B) Fan fuse 6.3 A (slow)
- (C) Refrigerant circuit controller fuse 6.3 A (slow)
- (D) Inverter
- (E) Mains terminals 400 V/50 Hz:  
See page 53.
- (F) Terminal for Modbus cable between indoor/outdoor unit: See next chapter.



**Electrical connection** (cont.)**Outdoor unit with 2 fans, 400 V~**

- Ⓒ Refrigerant circuit controller fuse 6.3 A (slow)
- Ⓓ Inverter
- Ⓔ Mains terminals 230 V/50 Hz:  
See page 53.
- Ⓕ Terminal for Modbus cable between indoor/outdoor unit: See next chapter.

Fig. 44

- Ⓐ EEV PCB (refrigerant circuit controller)
- Ⓑ Fan fuse 6.3 A (slow)

**Connecting the Modbus cable between the indoor and outdoor unit**

Use a flexible data cable with a minimum cross-section of 0.14 mm<sup>2</sup>, e.g. LiYCY. No screen is required.

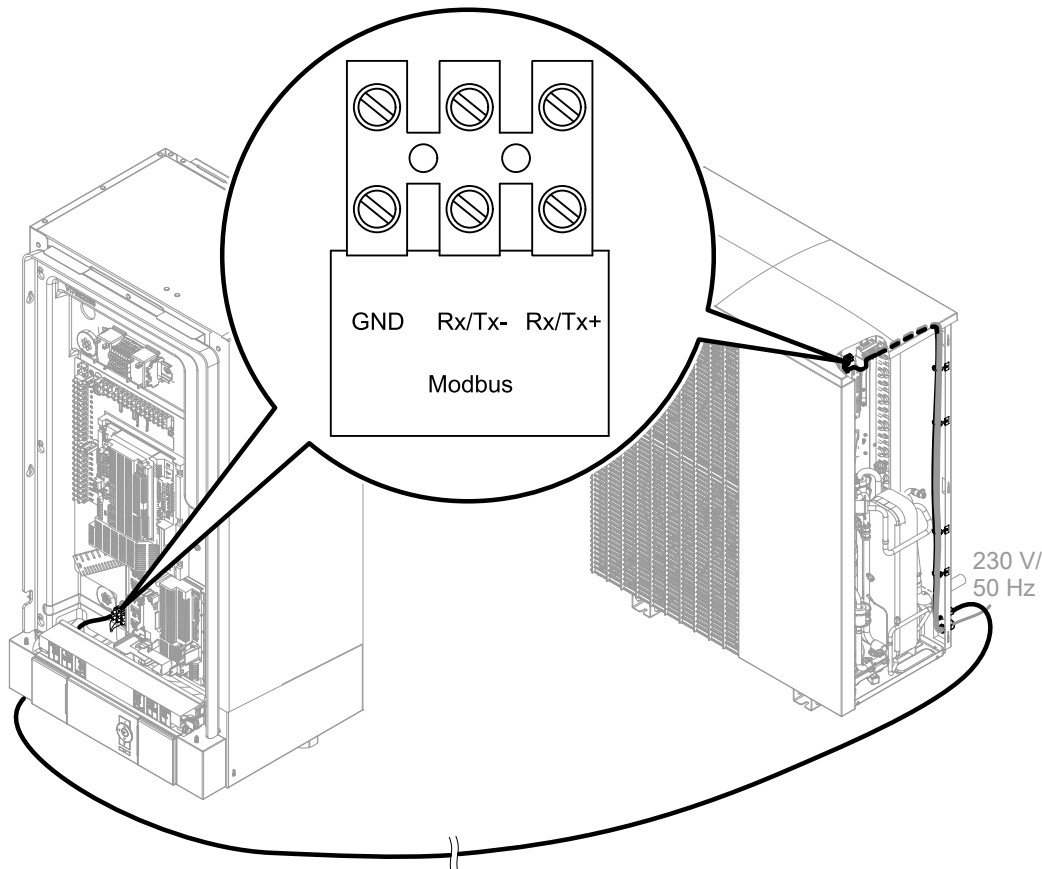



Fig. 45

**Power supply**

**Isolators for non-earthed conductors**

- Install an isolator in the power cable to provide omnipolar separation from the mains for all active conductors, corresponding to overvoltage category III (3 mm) for full isolation. This isolator must be fitted in the permanent electrical installation in line with installation requirements, e.g. mains isolator or upstream circuit breaker.
- We additionally recommend installing an AC/DC-sensitive RCD (RCD class B ) for DC (fault) currents that can occur with energy efficient equipment.
- Residual current devices to DIN VDE 0100-530 selecting and sizing.

**!** **Danger** Incorrect electrical installations can lead to serious injury from electrical current and result in appliance damage.

Connect the power supply and implement all safety measures (e.g. RCD circuit) in accordance with the following regulations:

- IEC 60364-4-41
- VDE regulations
- TAR low voltage VDE-AR-N-4100

**!** **Danger** The absence of system component earthing can lead to serious injury from electrical current and component damage in the event of an electrical fault.  
The appliance and pipework must be connected to the equipotential bonding of the building.

**!** **Danger** Incorrect core assignment can lead to serious injury from electrical current and result in appliance damage.  
Never interchange cores "L" and "N".

**Power supply** (cont.)

- In negotiations with your power supply utility, different supply tariffs for the main power circuits may be offered.  
Observe the technical connection conditions of the power supply utility.
- If the compressor and/or instantaneous heating water heater are operated at an economy tariff (power-OFF), either provide an additional cable (e.g. 3 x 1.5 mm<sup>2</sup>) for the power-OFF signal from the distribution board (meter box) to the heat pump control unit.  
**or**  
Combine the cables for the power-OFF signal and for the heat pump control unit power supply (3 x 1.5 mm<sup>2</sup>) in a 5-core cable.
- The assignment of the power-OFF (for compressor and/or instantaneous heating water heater) is made via the type of connection and by setting parameters in the heat pump control unit.  
In Germany, the power supply can be cut for a maximum of 3 x 2 hours per day (24 h).
- The **heat pump control unit/PCB** must be supplied **without** power-OFF. Tariffs subject to possible shut-down must not be used here.
- When using power generated on site (use of power generated by the PV system to meet own requirements):  
During the power-OFF period, it is **not** possible to operate the compressor utilising power generated on site.
- Protect the power cable to the heat pump control unit with an MCB/fuse of max. 16 A.
- For accessories and external components that will not be connected to the heat pump control unit, provide the power supply via the same MCB/fuse, or at least on the same phase, as the heat pump control unit.  
Connection to the same MCB/fuse provides additional safety when the power is switched off. Observe the power consumption of the connected consumers.
- If the mains connection is made with a flexible power cable, it must be ensured that the live conductors are pulled taut before the earth conductor in the event of strain relief failure. The length of the earth conductor wire will depend on the design.

**Heat pump control unit power supply 230 V~**

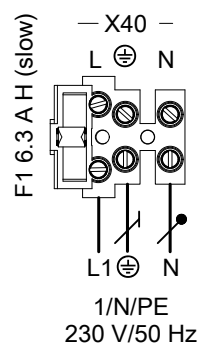

Fig. 46

**Note**

- This connection must be made with a flexible power cable.
- This supply must **never** be blocked.
- Max. fuse rating 16 A
- Standard tariff: No economy tariff with power-OFF facility possible
- Recommended flexible power cable: 3 x 1.5 mm<sup>2</sup>
- Recommended flexible power cable with power-OFF facility: 5 x 1.5 mm<sup>2</sup>

**Instantaneous heating water heater power supply**

Instantaneous heating water heater:

- Type AWO(-M)-E 201.A/AWO(-M)-E-AC 201.A:  
Factory-fitted
- Type AWO(-M) 201.A:  
Accessories

**Power supply** (cont.)

**1/N/PE 230 V/50 Hz**

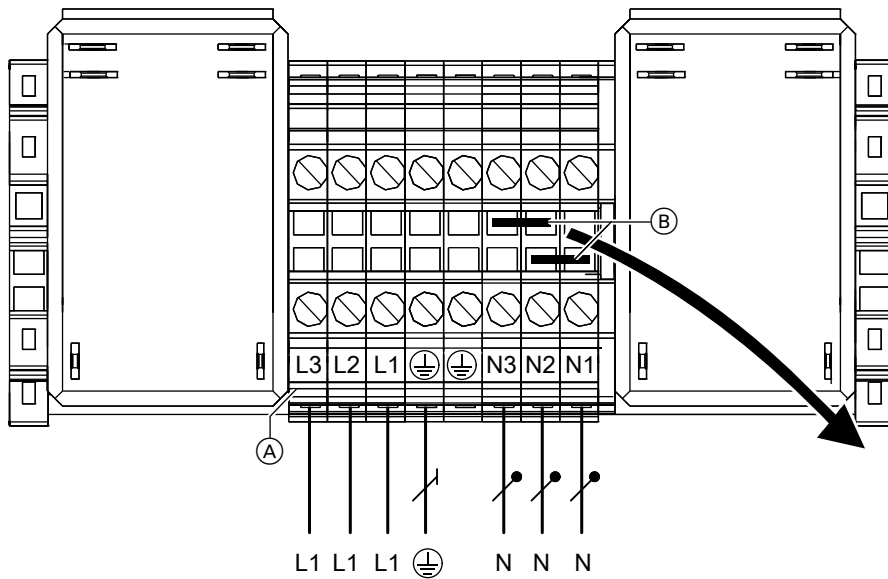

Fig. 47

- Ⓐ Mains terminals, switching module, instantaneous heating water heater
- Ⓑ Jumpers

Remove **both** jumpers Ⓑ in the case of a 1/N/PE 230 V/50 Hz power supply.

- Recommended power cable:  
**7 x 2.5 mm<sup>2</sup>**
- Max. fuse rating 16 A
- Economy tariff and power-OFF can be applied

**3/N/PE 400 V/50 Hz**

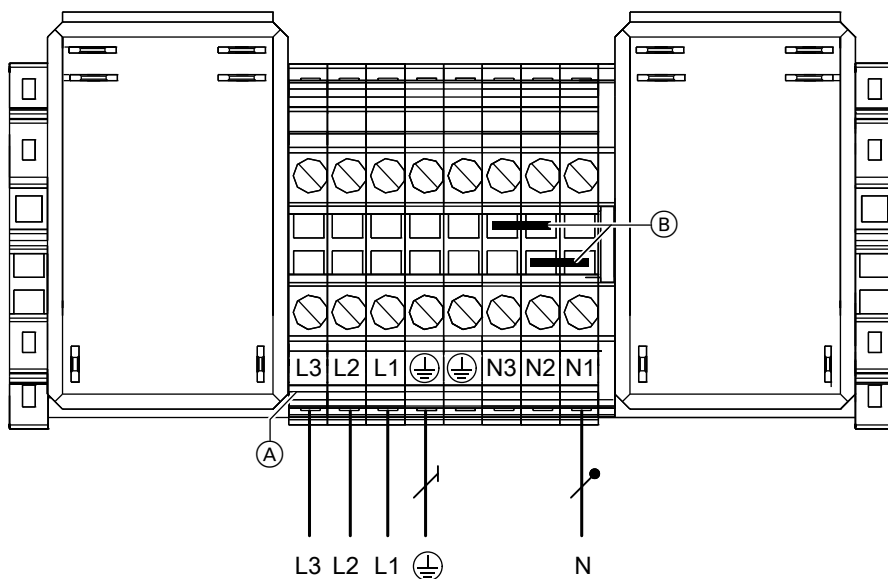

Fig. 48

- Ⓐ Mains terminals, switching module, instantaneous heating water heater
- Ⓑ Jumpers

**Power supply** (cont.)

Do **not** remove jumpers (B) in the case of a 3/N/PE 400 V/50 Hz power supply.

- Recommended power cable:  
**5 x 2.5 mm<sup>2</sup>**
- Max. fuse rating 16 A
- Economy tariff and power-OFF can be applied

**Outdoor unit: Power supply**

- Economy tariff and power-OFF can be used.
- No parameters need to be set when using economy tariff with power-OFF. The compressor is shut down during the power-OFF time.
- During power-OFF, the diagnostic functions for the outdoor unit are not supported.

**Note**

*Free terminals for internal use.*

**Outdoor unit power supply 230 V~**

Fig. 49

- (A) Outdoor unit wiring chamber: See "Opening the outdoor unit wiring chamber".
- (B) Power supply 230 V/50 Hz
- (C) Separator (supplied)

**Note**

*Nothing must be connected to L1 or L2.*

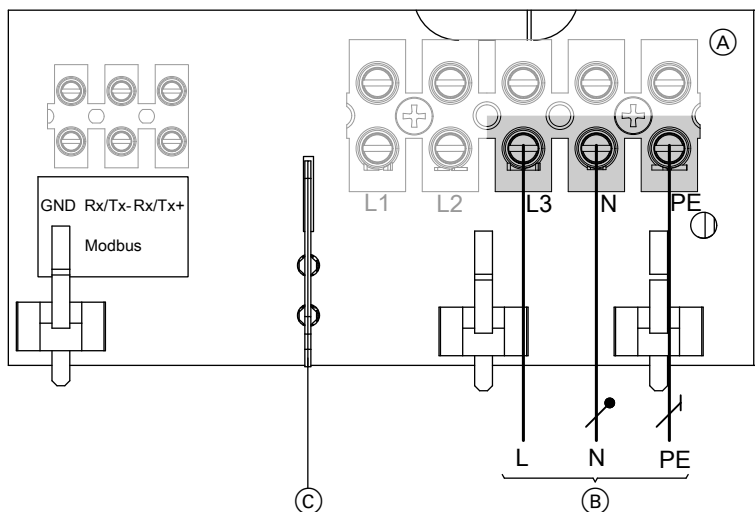
**Danger**

Serious injury can be caused by electric current and appliance damage can result if wires drift into the adjacent voltage area.

It is essential to insert the separator supplied.

## Installation sequence

### Power supply (cont.)

Types	Cable	Max. cable length	Max. fuse rating
201.A04	3 x 2.5 mm <sup>2</sup>	29 m	B16A
201.A06	3 x 2.5 mm <sup>2</sup>	29 m	B16A
201.A08	3 x 2.5 mm <sup>2</sup>	29 m	B16A
201.A10	3 x 2.5 mm <sup>2</sup> <b>Or</b> 3 x 4.0 mm <sup>2</sup>	20 m 32 m	B25A
201.A13	3 x 2.5 mm <sup>2</sup> <b>Or</b> 3 x 4.0 mm <sup>2</sup>	20 m 32 m	B25A
201.A16	3 x 2.5 mm <sup>2</sup> <b>Or</b> 3 x 4.0 mm <sup>2</sup>	20 m 32 m	B25A

### Outdoor unit power supply 400 V~

- !** **Please note**  
 Incorrect phase sequence can cause damage to the appliance.  
 Make the compressor power supply **only** in the phase sequence specified (see terminals) with a **clockwise** rotating field.

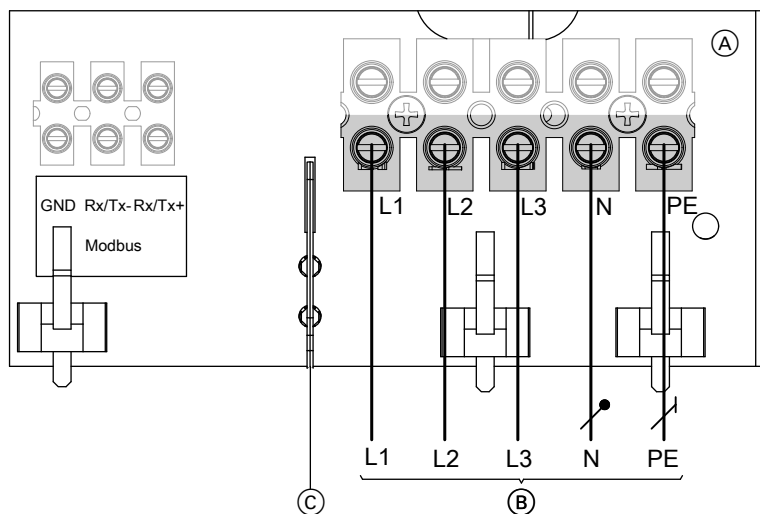

Fig. 50

- (A) Outdoor unit wiring chamber: See "Opening the outdoor unit wiring chamber".
- (B) Power supply 400 V/50 Hz
- (C) Separator (supplied)

- !** **Danger**  
 Serious injury can be caused by electric current and appliance damage can result if wires drift into the adjacent voltage area.  
 It is essential to insert the separator supplied.

**Power supply (cont.)**

Types	Cable	Max. cable length	Max. fuse rating
201.A10	5 x 2.5 mm <sup>2</sup>	30 m	B16 A
201.A13	5 x 2.5 mm <sup>2</sup>	30 m	B16 A
201.A16	5 x 2.5 mm <sup>2</sup>	30 m	B16 A

**Power supply with power-OFF: Without on-site load disconnection**

The power-OFF signal is connected directly to the heat pump control unit; with heat pump cascades the connection is only made at the lead heat pump. Parameter "**Output for instant. heating water heater at power-OFF 790A**" determines whether and at what stage an instantaneous heating water heater (if installed) remains operational during power-OFF.

**Note**

Observe the technical connection conditions of the relevant power supply utility.

- Ⓒ Heat pump compressor (outdoor unit)
- Ⓓ Heat pump control unit power supply: See chapter "Heat pump control unit power supply 230 V~"
- Ⓔ Premium tariff meter
- Ⓕ Ripple control receiver backup fuse
- Ⓖ Ripple control receiver (contact open: Power-OFF enabled); feed: TNC system
- Ⓗ Economy tariff meter
- Ⓙ Feed: TNC system

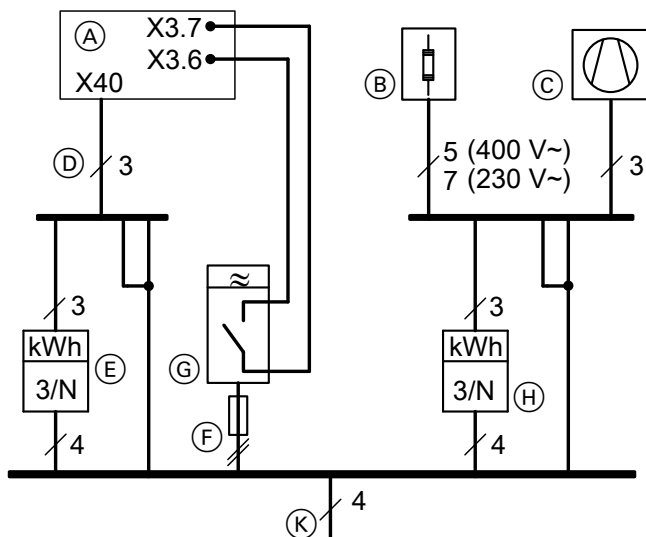

Fig. 51 Diagram excluding fuses and RCD

- Ⓐ Heat pump control unit (indoor unit, luster terminals: See chapter "Indoor unit: Electrical terminal areas")
- Ⓑ Instantaneous heating water heater (if installed)

**Power supply with power-OFF: With on-site load disconnection**

The power-OFF signal is connected to the on-site contactor of the economy tariff power supply and to the heat pump control unit.

With heat pump cascades, the power-OFF signal must be connected to **all** heat pumps in parallel and **in the same phase**. An additional contactor relay is required for this: See page 56.

The compressor **and** instantaneous heating water heater (if installed) are "forced" off when power-OFF is active.

**Note**

Observe the technical connection conditions of the relevant power supply utility.

**Power supply (cont.)**

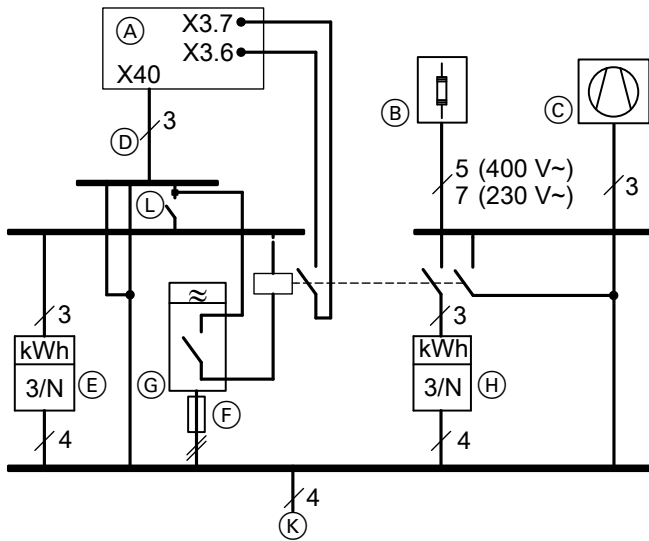

- Ⓒ Heat pump compressor (outdoor unit)
- Ⓓ Heat pump control unit power supply: See chapter "Heat pump control unit power supply 230 V~"
- Ⓔ Premium tariff meter
- Ⓕ Ripple control receiver backup fuse
- Ⓖ Ripple control receiver (contact open: Power-OFF enabled) with backup fuse
- Ⓗ Economy tariff meter
- Ⓚ Feed: TNC system
- Ⓛ Mains isolator

Fig. 52 Diagram excluding fuses and RCD

- Ⓐ Heat pump control unit (indoor unit, luster terminals: See chapter "Indoor unit: Electrical terminal areas")
- Ⓑ Instantaneous heating water heater (if installed)

**Connecting the power-OFF signal in heat pump cascades**

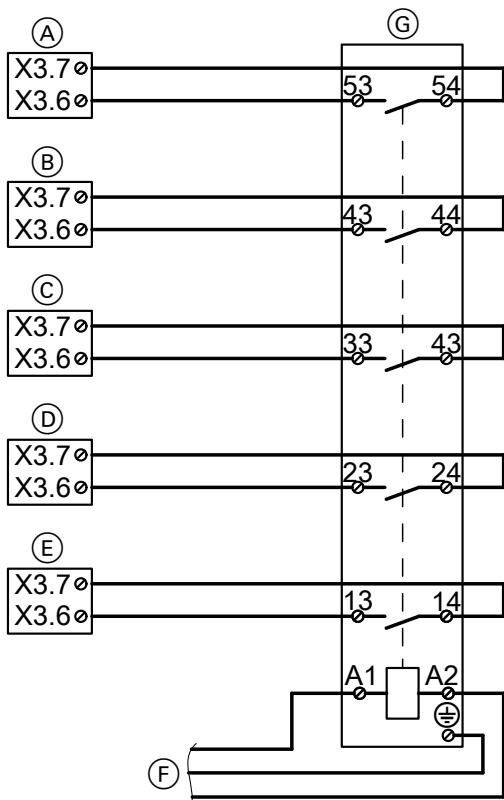

- Ⓒ Power-OFF terminal of lag heat pump 2
- Ⓓ Power-OFF terminal of lag heat pump 3
- Ⓔ Power-OFF terminal of lag heat pump 4
- Ⓕ Power-OFF signal
- Ⓖ Contactor relay (accessories)

Fig. 53

- Ⓐ Connecting power-OFF of lead heat pump (indoor unit, luster terminals, see chapter "Indoor unit: Electrical terminal areas")
- Ⓑ Power-OFF terminal of lag heat pump 1



**Power supply (cont.)**

**Mains power supply in conjunction with self-consumption**

Without power-OFF

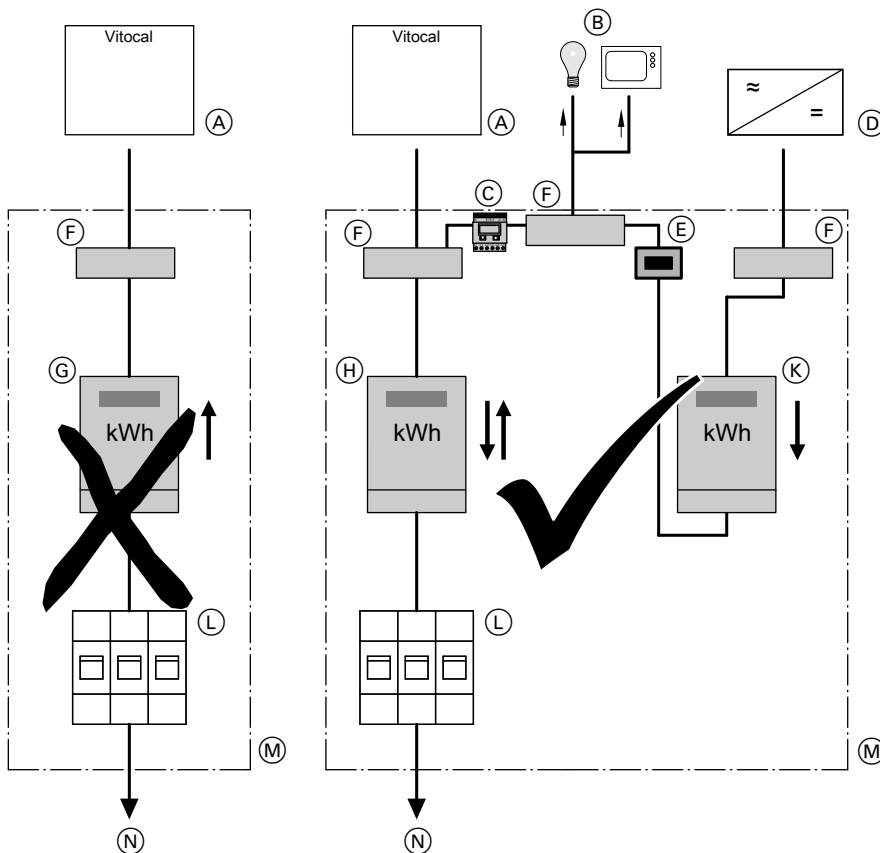

Fig. 54

- (A) Heat pump
- (B) Additional consumers (of self-generated power) in the household
- (C) Energy meter
- (D) Inverter
- (E) Isolator for the photovoltaic system
- (F) Terminal
- (G) Double-tariff meter (for special tariff for heat pumps)  
**Not permissible in conjunction with photovoltaic systems for self-consumption**
- (H) Bidirectional meter (for photovoltaic systems suitable for self-consumption):  
Energy drawn from power supply utility and energy exported to power supply utility
- (K) Meter with reversing block:  
For energy generated by the photovoltaic system
- (L) Isolator for domestic power supply connection (distribution panel)
- (M) Distribution panel
- (N) Domestic distribution box

**Smart Grid**

The Smart Grid functions are switched via the two PSU floating contacts.

Connection options for the two floating contacts:

- To EA1 extension as shown in Fig. 55
- To the heat pump control unit as shown in Fig. 56

**Power supply (cont.)**

**Connection to EA1 extension**

Condition: "Enable Smart Grid 7E80" must be at "1".

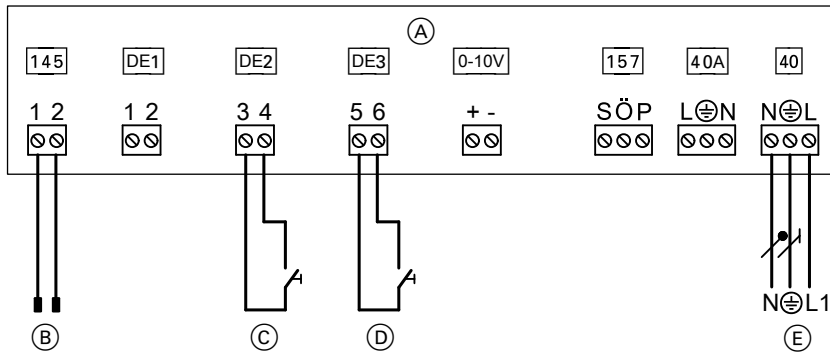

Fig. 55

- (A) EA1 extension
- (B) Connection to controller and sensor PCB
- (C) Floating N/O contact 1: The agreement of the power supply utility may be required

- (D) Floating N/O contact 2: The agreement of the power supply utility may be required
- (E) Power supply 1/N/PE 230 V/50 Hz

**Note**

- If Smart Grid is enabled ("Enable Smart Grid 7E80" set to "1"), both inputs DE2 and DE3 **cannot** be used for signals "External demand" or "External blocking".
- The power-OFF function is integral to Smart Grid. Therefore do **not** connect the power-OFF signal to terminals X3.6 and X3.7. Do **not** remove jumper.

**Note**

- If Smart Grid is connected to the two digital inputs on main PCB ("Enable Smart Grid 7E80" set to "4"), the external hook-up for the heating/cooling circuits **must not** be switched on ("Remote control 2003" set to "2"). Otherwise the Smart Grid will not be active.
- The power-OFF function is integral to Smart Grid. In this case, therefore, the power-OFF signal **must not** be connected to connections X3.6 and X3.7.

**Connection to heat pump control unit**

Condition: "Enable Smart Grid 7E80" must be at "4".

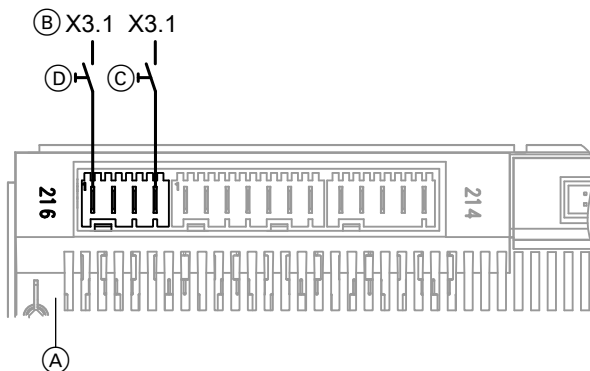

Fig. 56

- (A) Main PCB
- (B) Connection X3.1 (L') on the luster terminals
- (C) Floating contact 1: The agreement of the power supply utility may be required
- (D) Floating contact 2: The agreement of the power supply utility may be required

## Closing the heat pump

- !** **Please note**  
If a casing door is not securely closed this can lead to damage from condensation, vibrations and excessive noise.
- Seal the appliance so it is soundproof and diffusion-proof.
  - On pipe and hose outlets, ensure the thermal insulation is seated correctly.



- Danger**  
The absence of system component earthing can lead to serious injury from electrical current and component damage in the event of an electrical fault.  
Attach earth conductor to front panel and side panel.

### Indoor unit: Fitting the front panel

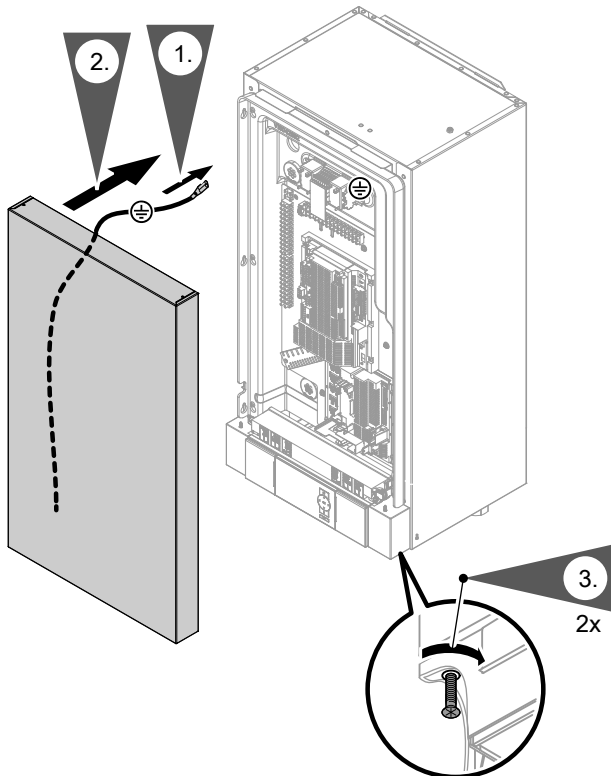

3. Ensure that the locking screws are tightened before operating.

Fig. 57

### Outdoor unit: Fitting the side cover

In reverse order to "Opening the outdoor unit wiring chamber": See page 25.



			Page
•	•	•	<b>1. Opening the heat pump</b> ..... 61
•	•	•	<b>2. Compiling reports</b> ..... 61
•	•	•	<b>3. Checking the refrigerant circuit for leaks</b> ..... 61
•	•	•	<b>4. Filling and venting the secondary side</b> ..... 62
•	•	•	<b>5. Checking the expansion vessel and heating circuit pressure</b> ..... 62
•	•	•	<b>6. Checking the indoor unit electrical connections for firm seating</b>
•	•	•	<b>7. Checking that the fan in the outdoor unit can run freely</b> ..... 63
•	•	•	<b>8. Cleaning the outdoor unit heat exchanger (evaporator)</b> ..... 64
•	•	•	<b>9. Checking the outdoor unit electrical connections for firm seating</b> ..... 64
•	•	•	<b>10. Closing the heat pump</b> ..... 64
•	•	•	<b>11. Switching on the power supply</b> ..... 64
•	•	•	<b>12. Starting the heat pump</b> ..... 65
•	•	•	<b>13. Commissioning the system</b> ..... 65
•	•	•	<b>14. Checking the heat pump for noise</b> ..... 76
•	•	•	<b>15. Checking the system function</b> ..... 76
•	•	•	<b>16. Instructing the system user</b> ..... 77



## Opening the heat pump



### Danger

Contact with live components can lead to serious injury from electric current. Some components on PCBs remain live even after the power supply has been switched off.

- **Do not touch** wiring chambers: See chapters "Indoor unit: Electrical terminal areas" and "Outdoor unit: Electrical terminal areas".
- When working on the appliances (indoor/outdoor units), isolate the system from the power supply, e.g. at the separate MCB/fuse or a mains isolator. Check that it is no longer live. Safeguard against unauthorised reconnection.
- Ensure that both the indoor unit and the outdoor unit are switched off from the power supply. Indoor unit and outdoor unit have separate mains connections. Even if the mains supply to the indoor unit is switched off, there is still power to the outdoor unit and vice versa.
- Prior to working on the appliance, wait at least 4 min until the voltage has completely dropped out.



### Danger

The absence of system component earthing can lead to serious injury from electrical current and component damage in the event of an electrical fault.

All earth connectors **must** be reconnected. The appliance and pipework must be connected to the equipotential bonding of the building.



### Please note

Commissioning immediately after siting the appliance can lead to appliance damage. Wait **at least 30 min** between siting and commissioning the appliance.



### Please note

Refrigerant can escape when working on the refrigerant circuit.

- Work on the refrigerant circuit must **only** be carried out by a certified contractor (in accordance with Regulations (EU) No 517/2014 and 2015/2067).
- Ventilate the installation room during installation, maintenance and service, e.g. through windows or doors.
- Do not operate an ignition source in the installation room.

1. Remove front panel: See page 28.
2. When work is complete, close the heat pump: See page 59.



For commissioning the appliance, see also the "Vitotronic 200" operating instructions.



## Compiling reports

Enter the readings taken during commissioning into the reports on page 89 onwards and the operator's log (if available).



## Checking the refrigerant circuit for leaks

Check the connections for refrigerant leaks.



### Danger

Direct contact with refrigerant can be harmful to the skin.

Wear safety goggles and protective gloves when working on the refrigerant circuit.



### Please note

Refrigerant can escape when working on the refrigerant circuit.

- Always observe regulations and guidelines on handling this type of refrigerant.
- Work on the refrigerant circuit must **only** be carried out by a certified contractor (in accordance with Regulation (EU) No 517/2014 and 2015/2067).



### Filling and venting the secondary side

Unsuitable fill and top-up water increases the level of deposits and corrosion. This can lead to system damage.

Hard water can also cause damage to the instantaneous heating water heater in particular.

Observe VDI 2035 regarding quality and amount of heating water, including fill and top-up water.

- Flush the heating system thoroughly before filling.
  - Only fill with water of potable quality.
  - Only fill and operate appliances that have an instantaneous heating water heater with softened water.
- For further information about fill and top-up water: See technical guide "Heat pump principles".

- Moving the control unit panel into the service position:

See page 79.

- Opening the programming unit:

See page 78.

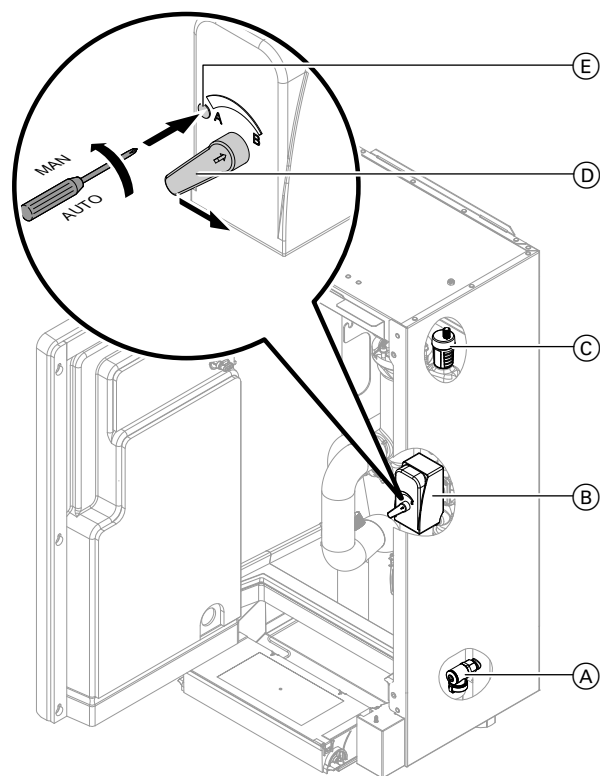

Fig. 58

1. Open any non-return valves installed on site.
2. Check the pre-charge pressure of the expansion vessel. Adjust the pre-charge pressure to match the system conditions if necessary.
3. Fill (flush) and vent the secondary circuit using drain & fill valve (A) or an on-site connection.



#### Please note

Leaking hydraulic connections lead to appliance damage.

- Check the internal and on-site hydraulic connections for leaks.
- In the event of leaks, switch off the appliance immediately. Drain off liquid via the drain valve. Check the seating of seal rings. **Always** replace displaced seal rings.

4. Move the control unit panel into the service position.
5. Open the programming unit.
6. Open the air discharge valve in quick-action air vent valve (C).
7. Check the system pressure at the pressure gauge. Top up with water if required.
  - Minimum system pressure: 0.8 bar (80 kPa)
  - Permissible operating pressure: 3.0 bar (0.3 MPa)
8. Move 3-way diverter valve (B) to its central position: Press (E). Turn anti-clockwise to lock into the "MAN" position. Move lever (D) to a vertical position.
9. Set the 3-way diverter valve to the "AUTO" position: Turn (E) clockwise.



### Checking the expansion vessel and heating circuit pressure



Observe engineering information.

Heat pump technical guide



### Checking the indoor unit electrical connections for firm seating

**Checking that the fan in the outdoor unit can run freely****Danger**

Contact with the fans while they are operating can result in serious cutting injuries.

- Isolate the outdoor unit from the power supply. Safeguard against unauthorised reconnection.
- Do not open the appliance until the fan has come to a stop.

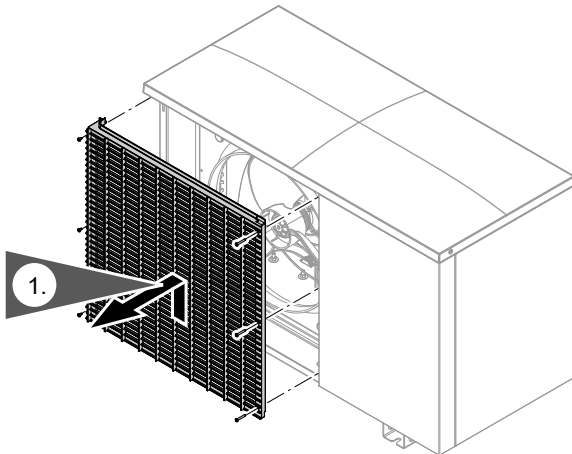
**Outdoor unit with 1 fan**

2. Turn the fan by hand.

Fig. 59

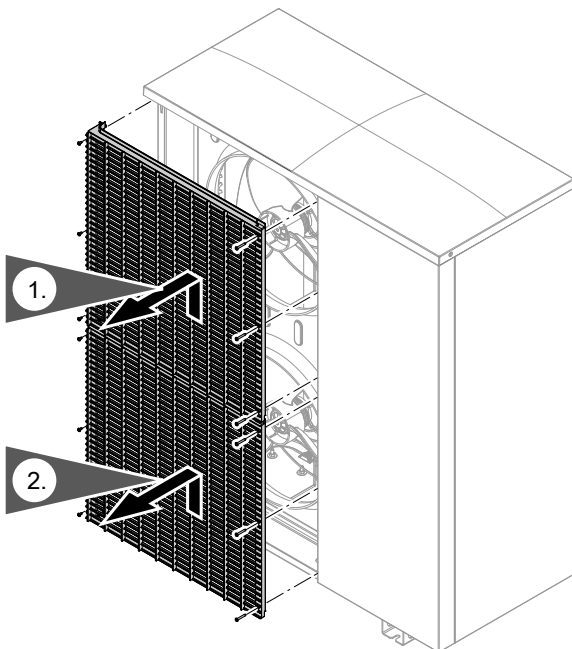
**Outdoor unit with 2 fans**

3. Turn the fan by hand.

Fig. 60



### Cleaning the outdoor unit heat exchanger (evaporator)



#### Danger

If you touch live components or they come into contact with water, this can result in serious injury due to electric shock.

- Isolate the outdoor unit from the power supply and safeguard against reconnection.
- Protect the outdoor unit against moisture.



#### Danger

Contact with the fans while they are operating can result in serious cutting injuries.

- Isolate the outdoor unit from the power supply and safeguard against reconnection.
- Do not open the appliance until the fan has come to a stop.

### Cleaning with compressed air

1. Open the outdoor unit casing.



#### Danger

The sharp edges of the heat exchanger (evaporator) can cause injuries. Avoid contact.

2. Clean the heat exchanger **from the inside out** with compressed air.



#### Please note

Excessive air pressure from the front and sides can result in the deformation of the aluminium fins of the heat exchanger. Only point the compressed air gun at the heat exchanger from the front and from an adequate distance.

3. Check the aluminium fins of the heat exchanger for deformation and scratches. If necessary, repair with a suitable tool.
4. Close the outdoor unit casing.



### Checking the outdoor unit electrical connections for firm seating



#### Danger

Contact with live components can lead to serious injury from electric current. Some components on PCBs remain live even after the power supply has been switched off.

- When working on the outdoor unit, isolate the system from the power supply, e.g. at a separate MCB/fuse or a mains isolator. Check the system is no longer live and safeguard against reconnection.
- Prior to working on the appliance, wait at least 4 min until the voltage on the charged capacitors has completely dropped out.



### Closing the heat pump

See page 59.



### Switching on the power supply

Switch on the power supply at the main MCB/fuse.





## Starting the heat pump

Observe the following sequence:

1. Switch ON outdoor unit voltage.
2. Switch ON indoor unit voltage.
3. Start indoor unit at the ON/OFF switch.



## Commissioning the system

Commissioning (configuration, parameter settings and function check) can be carried out with or without the commissioning wizard (see following chapter and service instructions for the heat pump control unit).

### Note

*The type and extent of the parameters depend on the appliance type, on the selected system scheme and the accessories employed.*

## Commissioning with the commissioning assistant

The commissioning assistant automatically guides you through all the menus where settings have to be made. For this, "Coding level 1" is automatically active.



### Please note

Incorrect operation at "Coding level 1" may result in damage to the appliance and the heating system. Observe the service instructions for the "Vito-tronic 200", otherwise the appliance warranty will be void.

Switch ON the ON/OFF switch on the control unit.

- The prompt "**Start commissioning?**" appears **automatically** on commissioning.

### Note

*The commissioning assistant can also be started manually:*

*To do this, press and hold  when switching on the control unit (progress bar visible).*

- When the unit is first commissioned, the display is in German.



Fig. 61

- Manually switching some appliance components during commissioning enables the control unit to display messages. These messages are not appliance faults.

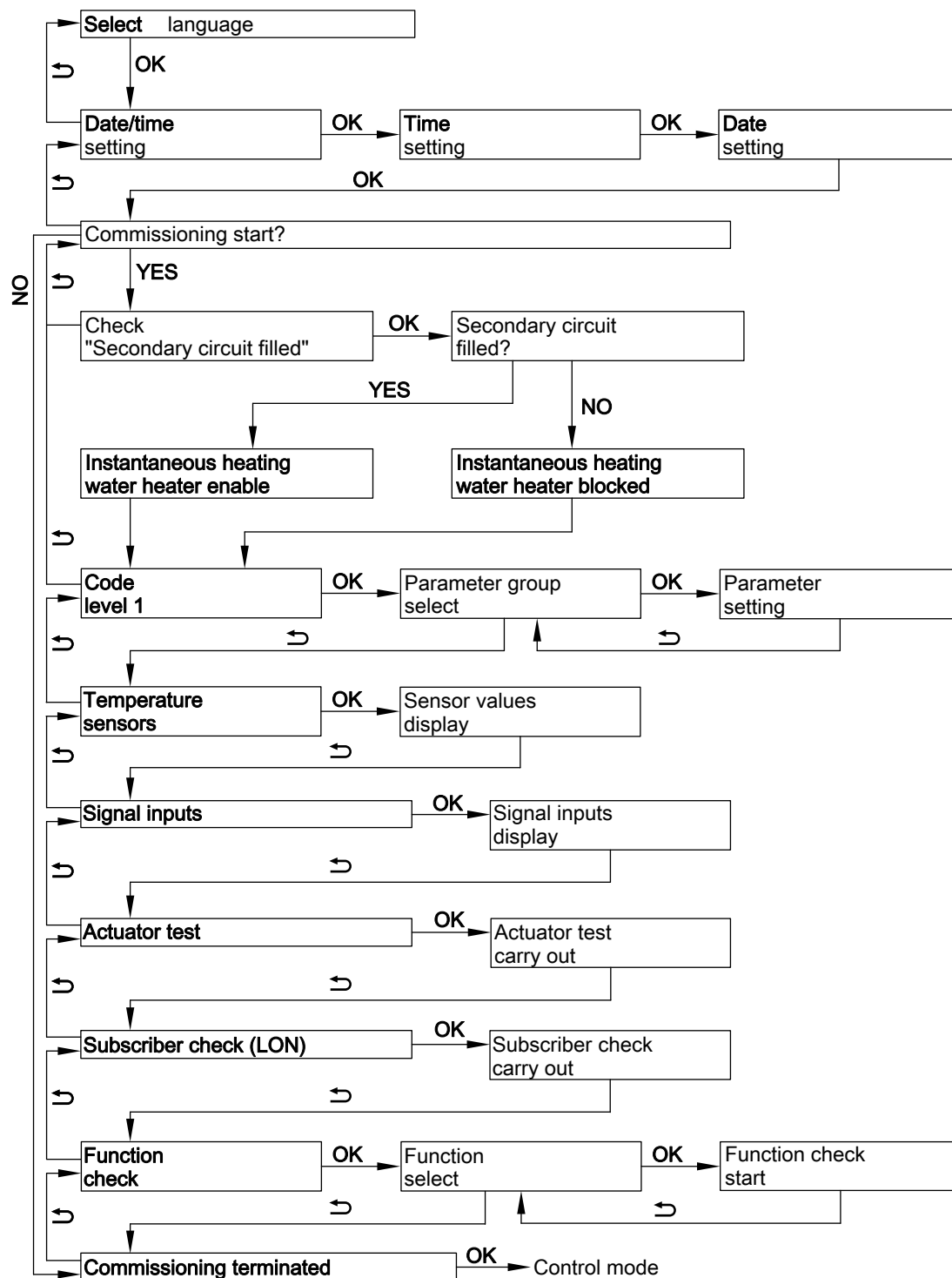

Fig. 62

## Commissioning without the commissioning assistant

### Activating the service menu

The service menu can be activated from any other menu.  
Press and hold **OK** + **≡** simultaneously for approx. 4 s.

### Deactivating the service menu

The service menu remains active until it is disabled with **"Terminate service?"**, or if no key is pressed for 30 min.



**Commissioning the system** (cont.)

**Setting parameters using "System scheme 7000" as an example**

To set a parameter, first select the parameter group and then the parameter.

**Service menu:**

1. Press and hold **OK** + simultaneously for approx. 4 s.
2. Select **"Coding level 1"**.
3. Select parameter group: **"System definition"**
4. Select parameter: **"System scheme 7000"**
5. Set a system scheme: e.g. **"6"**

Alternatively, if the service menu was already active:

**Extended menu:**

- 1.
2. **"Service"**
3. Select **"Coding level 1"**.
4. Select parameter group: **"System definition"**
5. Select parameter: **"System scheme 7000"**
6. Set a system scheme: e.g. **"6"**

**Required parameters for components connected on site**

Parameters may need to be set subject to the appliance type, the selected system scheme and the accessories used.

Overview of required parameters: See the following chapter.

**Detailed explanations of parameters**  
"Vitotronic 200" service instructions

**System scheme**

**Overview of all available system schemes**

Component	System scheme											
	0	1	2	3	4	5	6	7	8	9	10	11
<b>Heating circuit</b>												
A1/HC1	—	X	X	—	—	X	X	—	—	X	X	—
M2/HC2	—	—	—	X	X	X	X	X	X	X	X	—
M3/HC3	—	—	—	—	—	—	—	X	X	X	X	—
<b>DHW cylinder</b>	X	—	X	—	X	—	X	—	X	—	X	—
<b>Immersion heater</b>	○	—	○	—	○	—	○	—	○	—	○	—
<b>Heating water buffer cylinder</b>	—	○	○	X	X	X	X	X	X	X	X	—
<b>Heating water/coolant buffer cylinder</b>	—	○	○	○	○	○	○	○	○	○	○	—
<b>External heat generator</b>	○	○ <sup>*1</sup>	○ <sup>*1</sup>	○	○	○	○	○	○	○	○	—
<b>Instantaneous heating water heater</b>	○	○	○	○	○	○	○	○	○	○	○	○
<b>Swimming pool</b>	—	○	○	○	○	○	○	○	○	○	○	—
<b>Solar thermal system</b>	○	—	○	—	○	—	○	—	○	—	○	—
<b>Cooling</b>												
A1/HC1	—	○	○	—	—	○	○	—	—	○	○	—
M2/HC2	—	—	—	○	○	○	○	○	○	○	○	—
M3/HC3	—	—	—	—	—	—	—	○	○	○	○	—
Separate cooling circuit SKK	○	○	○	○	○	○	○	○	○	○	○	—
<b>Energy meter</b>	○	○	○	○	○	○	○	○	○	○	○	—
<b>Ventilation unit</b>	○	○	○	○	○	○	○	○	○	○	○	—

\*1 Only in conjunction with a buffer cylinder



X Component is selected.  
 O Component may be added.  
 For detailed information on system examples: See [www.viessmann-schemes.com](http://www.viessmann-schemes.com).

**Note**  
 Set **system scheme 11** for the lag heat pumps in a heat pump cascade.

**Parameters for circulation pumps and other components**

**Heating circuit pump**

Parameter	Setting
<b>"System definition" →</b>	
"System scheme 7000"	<ul style="list-style-type: none"> <li>▪ With heating circuit HC1 without mixer</li> <li style="text-align: center;"><b>or</b></li> <li>▪ With heating circuit HC2 with mixer</li> <li style="text-align: center;"><b>or</b></li> <li>▪ With heating circuit HC3 with mixer</li> </ul>

**DHW circulation pump**

Parameter	Setting
<b>Extended menu →</b>	
"Time program DHW circulation"	Set a time program.

**Circulation pump for DHW reheating**

Parameter	Setting
<b>"External heat source" →</b>	
"Enable external heat source 7B00"	"1"
"Enable external heat source for DHW heating 7B0D"	"1"

**Mixer extension kit for heating circuit M3/HC3**

Parameter	Setting
<b>"System definition" →</b>	
"System scheme 7000"	With heating circuit HC3  <b>Note</b> Set rotary switch S1 in the extension kit to "2": See "Mixer extension kit" installation instructions.

**Remote control for heating/cooling circuit or Vitocomfort 200**

Parameter	Setting
<b>"Heating circuit 1"/"Heating circuit 2"/"Heating circuit 3" →</b>	
"Remote control 2003" or "Remote control 3003" or "Remote control 4003"	"1"  <b>Note</b> To assign a heating circuit, set the code at the remote control: See "Vitolrol" installation instructions.



## Commissioning the system (cont.)

### External extension

Parameter	Setting
<b>"System definition" →</b>	
"External extension 7010"	"1" EA1 extension "2" AM1 extension "3" EA1 and AM1 extensions  <b>Note</b> <i>For parameters for external functions, see the following table.</i>

### Parameters for external functions

#### External demand

Parameter	Setting
<b>"Internal hydraulics" → if necessary</b>	
"Flow temperature external demand 730C"	Set flow temperature for external demand

#### External starting of the compressor; mixer in control mode or OPEN

Parameter	Setting
<b>"System definition" →</b>	
"Effect of external demand on heat pump/heating circuits 7014"	"0" to "7" (Observe parameter "Flow temperature external demand 730C")

#### External changeover of the operating status of various system components

Parameter	Setting
<b>"System definition" →</b>	
"System components for external changeover 7011"	"0" to "127"
"Operating status for external changeover 7012"	"0" to "3"
"Duration of external changeover 7013"	"0" to "12"

#### External blocking of compressor and pumps

Parameter	Setting
<b>"System definition" →</b>	
"Effect of external blocking on pumps/compressor 701A"	"0" to "31"

#### External blocking of the compressor; mixer in control mode or CLOSED

Parameter	Setting
<b>"System definition" →</b>	
"Effect of ext. blocking on heat pump/heating circuits 7015"	"0" to "8"
"Effect of external blocking on pumps/compressor 701A"	"0" to "31"



External hook-up for heating/cooling circuits

Parameter	Setting
<b>"Heating circuit 1"/"Heating circuit 2"/"Heating circuit 3" →</b>	
"Remote control 2003" or "Remote control 3003" or "Remote control 4003"	"2"

Type AWO(-M)-E-AC 201.A: Parameters for cooling function

Cooling function on systems without buffer cylinder

Parameter	Setting
<b>"Cooling" →</b>	
"Cooling function 7100"	"3"
"Cooling circuit 7101"	"1" Heating circuit HC1 "2" Heating circuit HC2 "3" Heating circuit HC3 "4" Separate cooling circuit SKK

Room temperature sensor for separate cooling circuit

Parameter	Setting
<b>"Cooling" →</b>	
"Ranking room temp sensor separate cooling circuit 7106"	"0" Connection F16 "1" Heating circuit HC1 "2" Heating circuit HC2 "3" Heating circuit HC3 "4" Do not adjust.

Cooling function on systems with heating water buffer cylinder

Parameter	Setting
<b>"Cooling" →</b>	
"Cooling function 7100"	"3"
"Cooling circuit 7101"	"1" Heating circuit HC1 "2" Heating circuit HC2 "3" Heating circuit HC3 "4" Separate cooling circuit SKK
<b>"Buffer cylinder" →</b>	
"Enable buffer cylinder/low loss header 7200"	"1"  <b>Note</b> <i>Perform settings only in conjunction with system schemes 1 and 2. System schemes 3 to 10 require a buffer cylinder, which is preset. Do not set with system scheme 11.</i>



## Commissioning the system (cont.)

### Room temperature sensor for separate cooling circuit

Parameter	Setting
<b>"Cooling" →</b>	
"Ranking room temp sensor separate cooling circuit 7106"	"0" Connection F16 "1" Heating circuit HC1 "2" Heating circuit HC2 "3" Heating circuit HC3 "4" Do not adjust.

### Cooling function in systems with a heating water/coolant buffer cylinder

Parameter	Setting
<b>"Cooling" →</b>	
"Cooling function 7100"	"3"
<b>"Buffer cylinder" →</b>	
"Enable buffer cylinder/low loss header 7200"	"2"
<b>"Heating circuit 1"/"Heating circuit 2"/"Heating circuit 3" →</b>	
"Cooling 2030" and/or "Cooling 3030" and/or "Cooling 4030"	"2"

### Parameters for solar DHW heating

Parameters in conjunction with solar control module type SM1	Setting
<b>"Solar" →</b>	
"Type solar control unit 7A00"	"3"
Parameter C0xx	See installation and service instructions for "Solar control module, type SM1".

### Parameters for instantaneous heating water heater

Parameter	Setting
<b>"Electr booster heater" →</b>	
"Enable instantaneous heating water heater 7900"	"1"
"Output for instant. heating water heater at power-OFF 790A"	"1" 3 kW "2" 6 kW "3" 9 kW



#### Please note

After the value "1" has been set for **"Enable instantaneous heating water heater 7900"**, the prompt **"Secondary circuit filled?"** appears automatically. If this prompt is responded to with **"No"**, the instantaneous heating water heater will not be enabled. Set **"Enable instantaneous heating water heater 7900"** to **"2"**. Fill the secondary circuit. Confirm prompt **"Secondary circuit filled?"** with **"Yes"**.



## Enable instantaneous heating water heater for DHW heating

Parameter	Setting
<b>"DHW" →</b>	
"Enable electric heaters for DHW heating 6015"	"1"

## Parameters for external heat generators

Parameter	Setting
<b>"External heat source" →</b>	
"Enable external heat source 7B00"	"1"

## Enable external heat source for DHW heating

Parameter	Setting
<b>"External heat source" →</b>	
"Enable external heat source for DHW heating 7B0D"	"1"

## Control strategy

Parameter	Setting
<b>"External heat source" →</b>	
"Fuel 7B7F"	"1" Gas "2" Oil
"Appliance control strategy 7BE1"	"0" Economical "1" Ecological "2" Fixed temperature limits

## Primary energy factors for ecological control strategy ("Appliance control strategy 7BE1" set to "1")

Parameter	Setting
<b>"External heat source" →</b>	
"Primary energy factor, electricity 7BE4"	"1" to "32767" ( $\pm$ 0.01 to 327.67)
"Primary energy factor, fossil 7BE5"	"1" to "32767" ( $\pm$ 0.01 to 327.67)

## Energy prices for economical control strategy ("Appliance control strategy 7BE1" set to "0")

Parameter	Setting
<b>"External heat source" →</b>	
"Electr. price, standard tariff 7BE8"	"1" to "32767" ( $\pm$ 0.01 to 327.67 ct/kWh)
"Electr. price, premium tariff 7BE9"	"1" to "32767" ( $\pm$ 0.01 to 327.67 ct/kWh)
"Electricity price, low tariff 7BEA"	"1" to "32767" ( $\pm$ 0.01 to 327.67 ct/kWh)
"7BEB Fossil fuel price, standard tariff"	"1" to "32767" ( $\pm$ 0.01 to 327.67 ct/kWh)

## Parameters for immersion heater

Parameters	Setting
<b>"DHW" →</b>	
"Enable electric heaters for DHW heating 6015"	"1"
"Enable booster heaters for DHW heating 6014"	"1"





## Commissioning the system (cont.)

### Parameters for swimming pool water heating

Parameter	Setting
<b>"System definition" →</b>	
"External extension 7010"	"1" or "3"
"Swimming pool 7008"	"1"

### Parameters for ventilation with Vitovent 200-C

Parameter	Setting
<b>"Ventilation" →</b>	
"Vitovent enable 7D00"	"2" Vitovent 200-C

### Further enabling for Vitovent 200-C if necessary

Parameter	Setting
<b>"Ventilation" →</b>	
"Enable preheater bank electric 7D01"	<p>"0" Defrosting without preheating coil ("<b>Strategy, passive frost protection 7D2C</b>")</p> <p>"1" Frost protection with preheating coil; defrosting via bypass</p> <p>"2" Frost protection with preheating coil; comfort function</p>
"Strategy, passive frost protection 7D2C"	<p>"0" Fans OFF</p> <p>"1" Defrosting via bypass</p> <p>"2" Supply air fan OFF</p>
"Type of heat exchanger 7D2E"	<p>"0" Countercurrent heat exchanger</p> <p>"1" Enthalpy heat exchanger</p>
"Installation position 7D2F"	<p>"0" Ceiling mounting</p> <p>"1" Wall mounting</p>
"Function, external 230 V input, ventilation 7D3A"	"1" External switch (bathroom switch) enabled

### Adjust values for Vitovent 200-C if necessary

Parameter	Setting
<b>"Ventilation" →</b>	
"Set room temperature 7D08"	"100" to "300" ( $\pm 10$ to 30 °C)
"Flow rate reduced ventilation 7D0A"	Subject to sizing  Ventilation unit service instructions
"Flow rate nominal ventilation 7D0B"	
"Flow rate intensive ventilation 7D0C"	

### Parameters for ventilation with Vitovent 200-W/300-C/300-W

Parameter	Setting
<b>"Ventilation" →</b>	
"Vitovent enable 7D00"	"3" Vitovent 200-W or Vitovent 300-C or Vitovent 300-W

**Adjust values for Vitovent 200-W/300-C/300-W if necessary**

Parameter	Setting
<b>"Ventilation" →</b>	
"Set room temperature C108"	Max. 4 K higher or lower than <b>"Standard room temperature 2000"</b> (adjustment value: $1 \pm 0.1$ °C)
"Background ventilation C109"	Subject to sizing  Ventilation unit service instructions
"Reduced ventilation C10A"	
"Standard ventilation C10B"	
"Intensive ventilation C10C"	
"Background ventilation, second fan duct C189" (Vitovent 200-W only)	
"Reduced ventilation, second fan duct C18A" (Vitovent 200-W only)	
"Standard ventilation, second fan duct C18B" (Vitovent 200-W only)	
"Intensive ventilation, second fan duct C18C" (Vitovent 200-W only)	

**Parameters for ventilation with Vitovent 300-F**

Parameter	Setting
<b>"Ventilation" →</b>	
"Vitovent enable 7D00"	"1" Vitovent 300-F

**Further enabling for Vitovent 300-F if necessary**

Parameter	Setting
<b>"Ventilation" →</b>	
"Enable preheater bank electric 7D01"	"1"
"Enable reheater bank hydraulic 7D02"	"1"
"Enable humidity sensor 7D05"	"1"
"Enable CO2 sensor 7D06"	"1"
"Type of heat exchanger 7D2E"	"0" Countercurrent heat exchanger "1" Enthalpy heat exchanger

**Adjust values for Vitovent 300-F if necessary**

Parameter	Setting
<b>"Ventilation" →</b>	
"Set room temperature 7D08"	"100" to "300" ( $\pm 10$ to 30 °C)
"Flow rate reduced ventilation 7D0A"	Subject to sizing  Ventilation unit service instructions
"Flow rate nominal ventilation 7D0B"	
"Flow rate intensive ventilation 7D0C"	



## Commissioning the system (cont.)

### Parameters for utilisation of power generated on site

Parameter	Setting
<b>"Photovoltaics" →</b>	
"Enable own energy consumption PV 7E00"	"1"
"Threshold for electrical power 7E04"	"0" to "300" ( $\triangleq$ 0 to 30 kW)

### Enable required functions for utilisation of power generated on site

Parameter	Setting
<b>"Photovoltaics" →</b>	
"Enable own energy consumption for set DHW temperature 2 7E10"	"1"
"Enable own energy consumption for DHW heating 7E11"	"1"
"Enable own energy consumption for heating water buffer cyl. 7E12"	"1"
"Enable own energy consumption for heating 7E13"	"1"
"Enable own energy consumption for cooling 7E15"	"1"
"Enable own energy consumption for coolant buffer cylinder 7E16"	"1"

### Specify the temperature differential to the selected set value for the chosen function

Parameter	Setting
<b>"Photovoltaics" →</b>	
"Raise set DHW cylinder temperature PV 7E21"	"0" to "500" ( $\triangleq$ 0 to 50 K)
"Raise set heating water buffer cylinder temp PV 7E22"	"0" to "400" ( $\triangleq$ 0 to 40 K)
"Raise set room temperature PV 7E23"	"0" to "100" ( $\triangleq$ 0 to 10 K)
"Reduce set room temperature PV 7E25"	"0" to "100" ( $\triangleq$ 0 to 10 K)
"Reduce set coolant buffer cylinder temperature PV 7E26"	"0" to "100" ( $\triangleq$ 0 to 10 K)

### Parameters for Smart Grid

Parameter	Setting
<b>"Smart Grid" →</b>	
"Enable Smart Grid 7E80"	"1" Connection to EA1 extension "4" Connection to heat pump control unit
"Smart Grid Enable elec heat 7E82"	"1" Stage 1 "2" Stage 2 "3" Stage 3

### Specify the temperature differential to the selected set value for the chosen function

Parameter	Setting
<b>"Smart Grid" →</b>	
"Smart Grid set value increase for DHW heating 7E91"	"0" to "500" ( $\triangleq$ 0 to 50 K)
"Smart Grid set value increase for htg wtr buff 7E92"	"0" to "400" ( $\triangleq$ 0 to 40 K)
"Smart Grid set value increase for centr htg 7E93"	"0" to "100" ( $\triangleq$ 0 to 10 K)
"Smart Grid set value decrease for room t cool 7E95"	"0" to "100" ( $\triangleq$ 0 to 10 K)



## Parameters for heat pump cascade

Parameters	Setting	
	Lead heat pump	Lag heat pump
<b>"Compressor" →</b>		
"Enable use of compressor stage 5012"	"0" to "15"	"0" to "15"
<b>"System definition" →</b>		
"System scheme 7000"	"0" to "10"	"11"
"Cascade control 700A"	"2"	"0"
"Use of heat pump in cascade 700C"	—	"0" to "15"
"Number of lag heat pumps 7029"	"1" to "4"	—
<b>"Communication" →</b>		
"Enable LON communication module 7710"	"1"	"1"
"Number of heat pump in cascade 7707"	—	"1" to "4"
"LON system number 7798" Within one LON, the system number must always be the same.	"1" to "5"	"1" to "5"
"LON subscriber number 7777" In the same LON system, each subscriber number can only be allocated once.	"1" to "99"	"1" to "99"
"LON fault manager 7779" Only one control unit per system may be configured as the fault manager.	"0" or "1"	"0" or "1"
"Source time 77FE"	"0"	"1"
"Send time 77FF"	"1"	"0"
"Source outside temperature 77FC"	"0"	"1"
"Send outside temperature 77FD"	"1"	"0"
"Interval for data transfer via LON 779C"	"20"	"20"
<b>"Buffer cylinder" →</b>		
"Enable buffer cylinder/low loss header 7200"	"1"	—
<b>"Electric heater" →</b>		
"Enable instantaneous heating water heater 7900"	"0" or "1"	"0" or "1"
"Enable electric heaters for DHW heating 6015"	"0" or "1"	—
"Enable electric heaters for DHW heating 7901"	—	"0" or "1"
"Enable instant. heating water heater for central heating 7902"	"0" or "1"	"0" or "1"



## Checking the heat pump for noise

Check the indoor and outdoor units for unusual noise, e.g. operating noise from the fan, compressor and circulation pumps. Venting again if required.



## Checking the system function

## Displaying the system overview

The system overview displays the status of the heat pump and system components as well as the temperatures.



## Checking the system function (cont.)

### Service menu:

1. Press **OK** + simultaneously and hold for approx. 4 s.
2. **"Diagnosis"**

### 3. "System overview"

4. to toggle between "System overview, generation side" and "System overview, consumption side"



"Vitotronic 200" service instructions

## Carrying out a function check

The function test serves to check the proper functioning of the different system components.

### Service menu:

1. Press **OK** + simultaneously and hold for approx. 4 s.
2. **"Service functions"**
3. **"Function check"**
4. Start the required function, e.g. **"DHW"**. Only those functions are shown that correspond to the actual system equipment level.  
During the function check, the system overview is displayed.

5. Terminate function with .



"Vitotronic 200" service instructions

### Notes on the "Cooling circuit SKK" function

- The 4-way diverter valve in the outdoor unit is at zero volt in heating mode.
- In cooling mode, the 4-way diverter valve is live. The heat pump is operated in reverse (refrigerant circuit reversal).

## Resetting the high limit safety cut-out for type AWO(-M)-E/AWO(-M)-E-AC 201.A

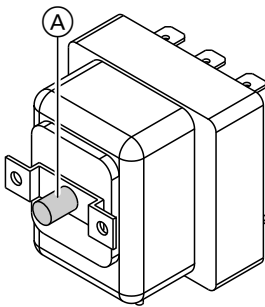

Fig. 63

- Ⓐ High limit safety cut-out reset button



### Please note

If the heat pump is exposed to temperatures below  $-15\text{ }^{\circ}\text{C}$ , e.g. during storage or transport, the high limit safety cut-out of the instantaneous heating water heater may respond. In this case, the instantaneous heating water heater will not heat up.

Heat up the high limit safety cut-out to above  $20\text{ }^{\circ}\text{C}$ . Press the reset button of the high limit safety cut-out.

### Note

The high limit safety cut-out can only be reset if the temperature at the sensor is below  $85\text{--}8\text{ }^{\circ}\text{C}$ .



## Instructing the system user

The system installer should hand the operating instructions to the system user and instruct the user in operating the system. This also includes all components added as accessories, such as remote controls.

Equipment and functions of the heating system must be entered in the form in the appendix to the operating instructions.

The system installer should also provide information on the required maintenance.

## Overview of electrical components

- **Indoor unit:**  
See page 36 onwards.
- **Outdoor unit:**  
See page 48 onwards.

## Indoor unit: Opening the programming unit

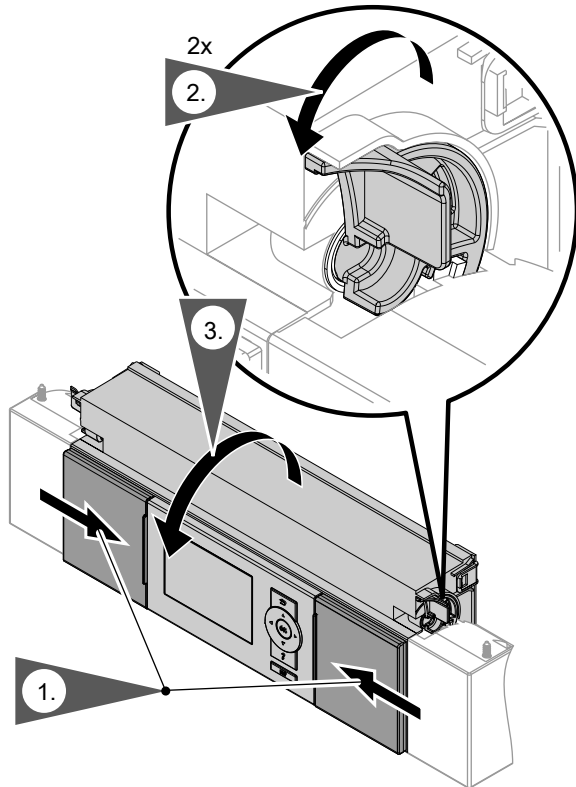

Fig. 64

Remove the cover from the programming unit if required

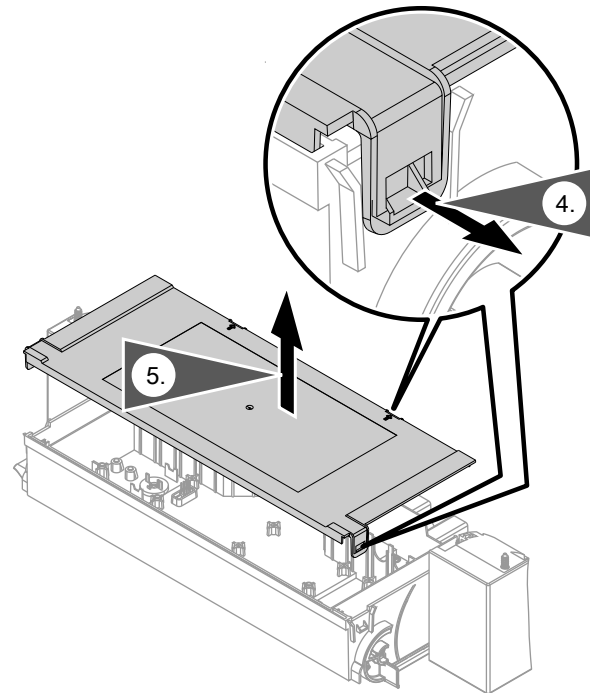

Fig. 65

Indoor unit: Placing the control unit panel in its service position

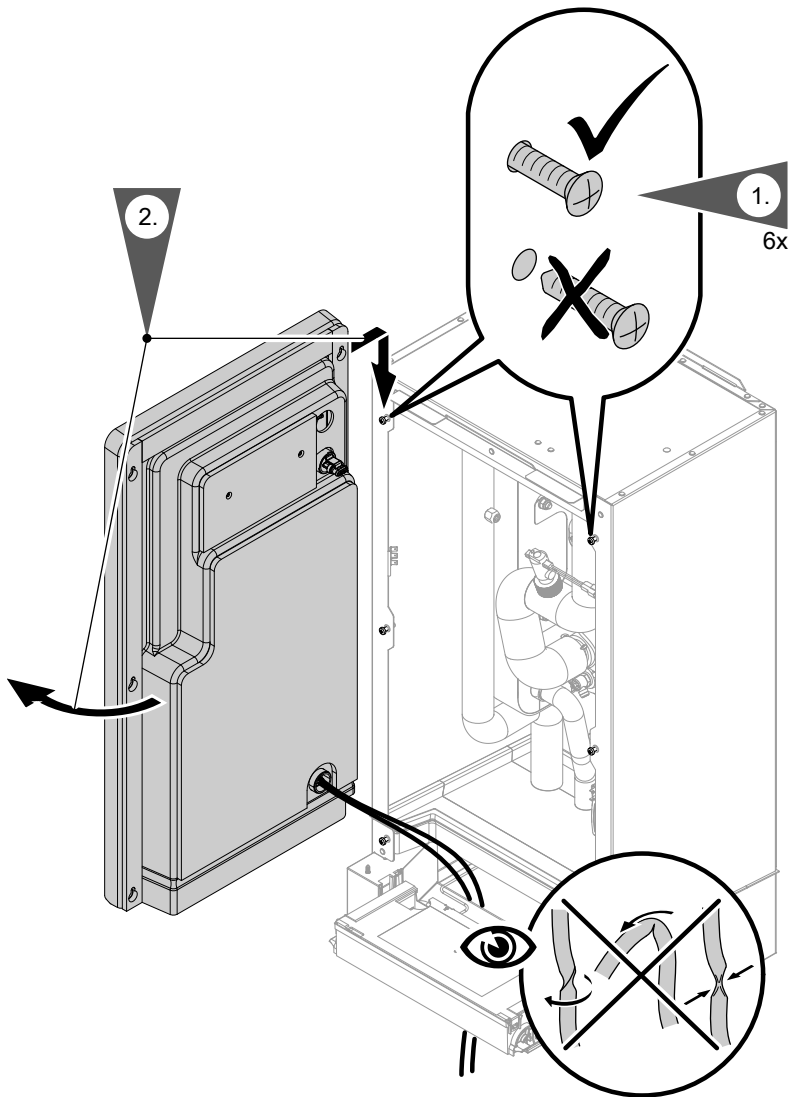
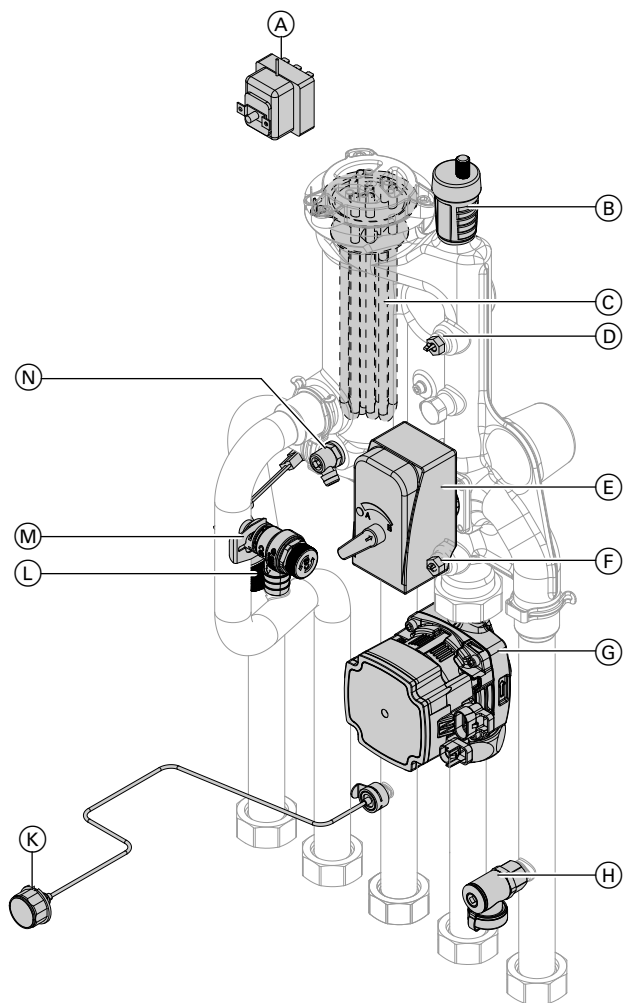

Fig. 66

## Indoor unit: Overview of internal components



- Ⓒ Type AWO(-M)-E/AWO(-M)-E-AC 201.A only:  
Instantaneous heating water heater
- Ⓓ Flow temperature sensor for secondary circuit (F8)
- Ⓔ 3-way diverter valve "central heating/DHW heating"
- Ⓕ Secondary circuit return temperature sensor (F9)
- Ⓖ Secondary pump
- Ⓗ Secondary circuit drain & fill valve
- Ⓚ Pressure gauge
- Ⓛ Flow switch
- Ⓜ Safety valve
- Ⓝ Drain valve

Fig. 67

- Ⓐ Type AWO(-M)-E/AWO(-M)-E-AC 201.A only:  
High limit safety cut-out (STB), instantaneous heating water heater
- Ⓑ Quick-action air vent valve G  $\frac{3}{8}$

## Outdoor unit: Overview of internal components

- ⚠ Danger**  
Contact with live components can lead to serious injury from electric current. Some components on PCBs remain live even after the power supply has been switched off.
- When working on the outdoor unit, isolate the system from the power supply, e.g. at a separate MCB/fuse or a mains isolator. Check the system is no longer live and safeguard against reconnection.
  - Prior to working on the appliance, wait at least 4 min until the voltage on the charged capacitors has completely dropped out.



## Outdoor unit: Overview of internal components (cont.)

## Outdoor unit with 1 fan

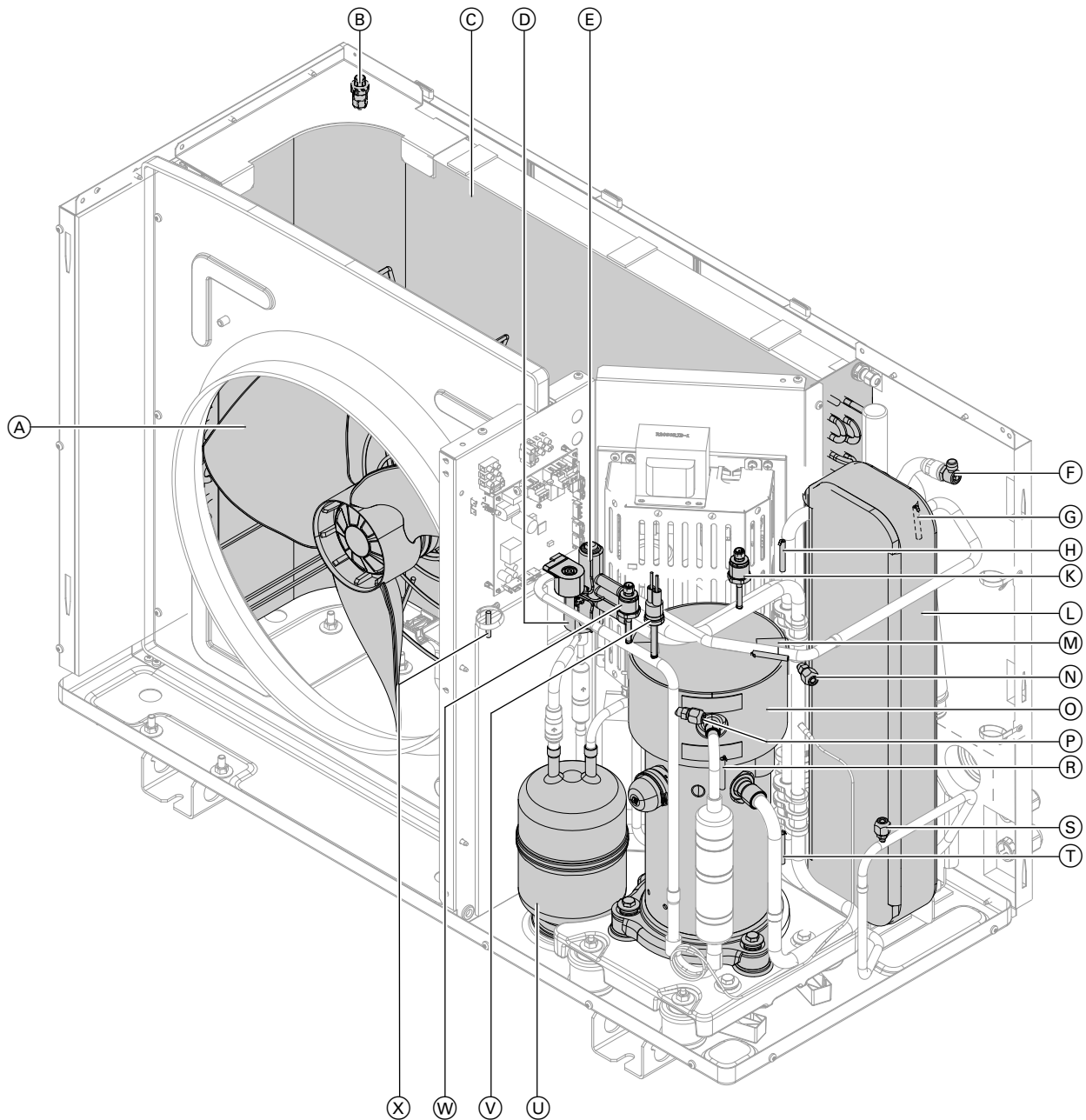

Fig. 68

- |   |   |
|---|---|
| (A) Fan   | (M) Reversible suction gas temperature sensor (T3)            |
| (B) Air intake temperature sensor (T5)  | (N) Schrader valve, low pressure side                         |
| (C) Heat exchanger (evaporator)   | (O) Compressor  |
| (D) Electronic expansion valve  | (P) Schrader valve, high pressure side                        |
| (E) 4-way diverter valve  | (R) Hot gas temperature sensor (T6)                           |
| (F) Secondary circuit air vent valve  | (S) Schrader valve, high pressure side                        |
| (G) Secondary circuit flow temperature sensor<br>upstream of instantaneous heating water heater<br>(T1) | (T) Compressor suction gas temperature sensor (T4)            |
| (H) Evaporator suction gas temperature sensor (T7)  | (U) Refrigerant receiver                                      |
| (K) Low pressure sensor   | (V) Safety high pressure switch                               |
| (L) Condenser   | (W) High pressure sensor                                      |
|   | (X) Refrigerant circuit controller temperature sensor<br>(T2) |

**Outdoor unit: Overview of internal components (cont.)**

**Outdoor unit with 2 fans**

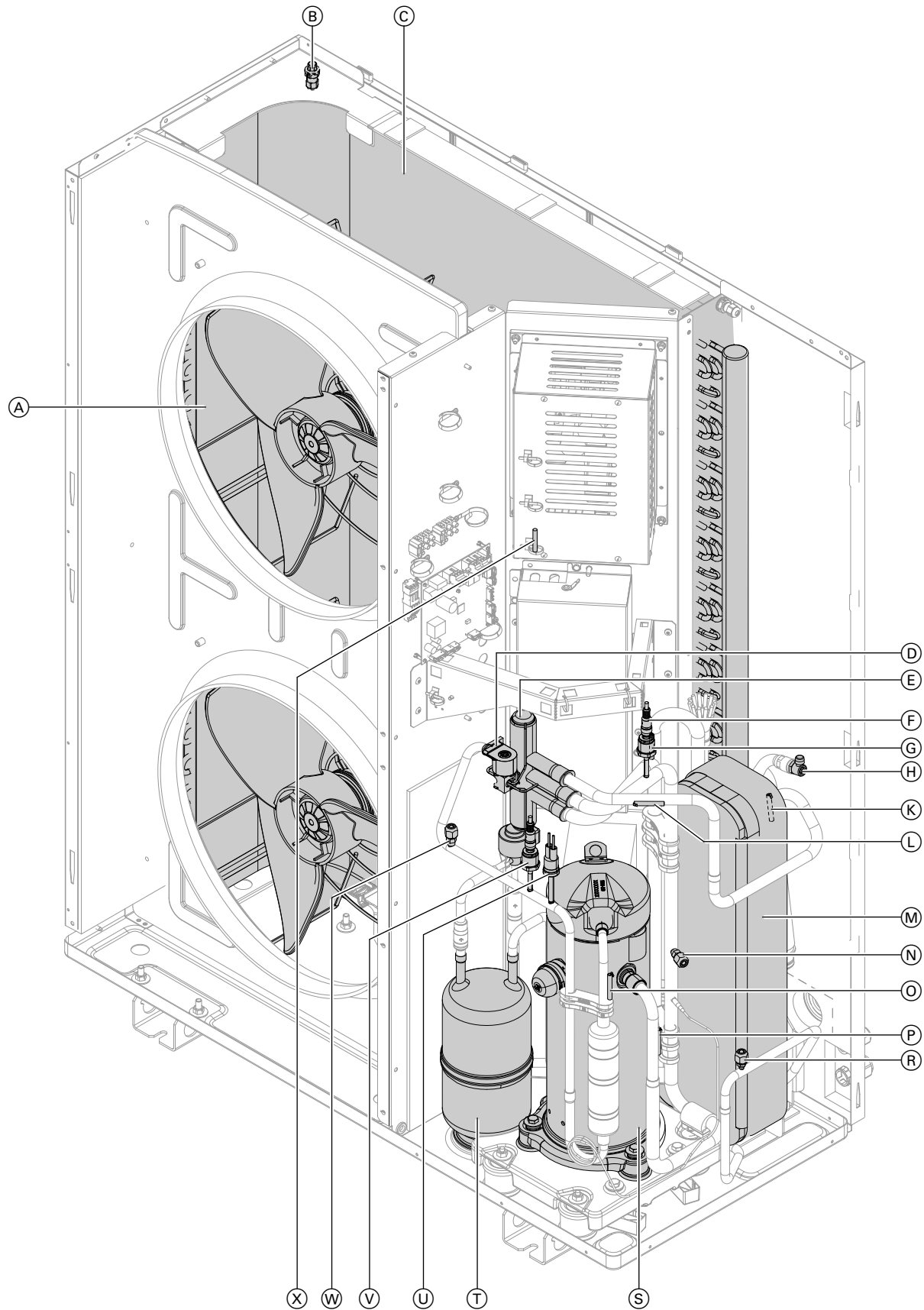

Fig. 69

- Ⓐ Fan
- Ⓑ Air intake temperature sensor (T5)
- Ⓒ Heat exchanger (evaporator)
- Ⓓ Electronic expansion valve

**Outdoor unit: Overview of internal components** (cont.)

- |  |  |
|--|--|
| <ul style="list-style-type: none"> <li>Ⓔ 4-way diverter valve</li> <li>Ⓕ Secondary circuit flow temperature sensor upstream of instantaneous heating water heater (T1)</li> <li>Ⓖ Low pressure sensor</li> <li>Ⓗ Secondary circuit air vent valve</li> <li>Ⓚ Evaporator suction gas temperature sensor (T7)</li> <li>Ⓛ Reversible suction gas temperature sensor (T3)</li> <li>Ⓜ Condenser</li> <li>Ⓝ Schrader valve, low pressure side</li> </ul> | <ul style="list-style-type: none"> <li>Ⓞ Hot gas temperature sensor (T6)</li> <li>Ⓟ Compressor suction gas temperature sensor (T4)</li> <li>Ⓡ Schrader valve, high pressure side</li> <li>Ⓢ Compressor</li> <li>Ⓣ Refrigerant receiver</li> <li>Ⓤ Safety high pressure switch</li> <li>Ⓥ High pressure sensor</li> <li>Ⓦ Schrader valve, high pressure side</li> <li>Ⓧ Refrigerant circuit controller temperature sensor (T2)</li> </ul> |
|--|--|

**Draining secondary side heat pump**

1. Close the on-site boiler drain & fill valve.
2. Drain the heat pump at the drain & fill valve in the secondary circuit: See chapter "Indoor unit: Overview of internal components".

**Checking the temperature sensors****Connection to the indoor unit**

Temperature sensors are connected to the controller and sensor PCB: See page 44.

Temperature sensor	Test element
<ul style="list-style-type: none"> <li>▪ Outside temperature sensor (F0)</li> <li>▪ Buffer temperature sensor (F4)</li> <li>▪ Cylinder temperature sensors top (F6) and bottom (F7)</li> <li>▪ System flow temperature sensor (F13)</li> <li>▪ Cooling circuit flow temperature sensor (direct heating circuit A1/HC1 or separate cooling circuit SKK) (F14)</li> <li>▪ Boiler water temperature sensor, external heat generator (F20)</li> <li>▪ For heat pump cascades: Buffer outlet temperature sensor (F23)</li> <li>▪ Room temperature sensors</li> </ul>	NTC 10 kΩ
<ul style="list-style-type: none"> <li>▪ For heat pump cascades: Swimming pool flow temperature sensor (F21)</li> </ul>	NTC 20 kΩ
<ul style="list-style-type: none"> <li>▪ Flow temperature sensor for secondary circuit (F8)</li> <li>▪ Secondary circuit return temperature sensor (F9)</li> </ul>	Pt500A (PTC)

**Connection to the outdoor unit**

Temperature sensors are connected to the refrigerant circuit controller in the outdoor unit (see label in the outdoor unit): See page 81.

Temperature sensor	Test element
<ul style="list-style-type: none"> <li>▪ Refrigerant circuit controller temperature sensor (T2)</li> <li>▪ Compressor suction gas temperature sensor (T4)</li> <li>▪ Air intake temperature sensor (T5)</li> <li>▪ Hot gas temperature sensor (T6)</li> <li>▪ Evaporator suction gas temperature sensor (T7)</li> <li>▪ Secondary circuit flow temperature sensor (T1)</li> <li>▪ Reversible suction gas temperature sensor (T3)</li> </ul>	NTC 10 kΩ

## Checking the temperature sensors (cont.)

### Indoor unit: Viessmann NTC 10 k $\Omega$ (blue marking)

$\vartheta / ^\circ\text{C}$	R / k $\Omega$	$\vartheta / ^\circ\text{C}$	R / k $\Omega$	$\vartheta / ^\circ\text{C}$	R / k $\Omega$	$\vartheta / ^\circ\text{C}$	R / k $\Omega$	$\vartheta / ^\circ\text{C}$	R / k $\Omega$	$\vartheta / ^\circ\text{C}$	R / k $\Omega$
-40	336.500	-8	49.647	24	10.449	56	2.878	88	0.976	120	0.389
-39	314.870	-7	47.055	25	10.000	57	2.774	89	0.946	121	0.379
-38	294.780	-6	44.614	26	9.572	58	2.675	90	0.918	122	0.369
-37	276.100	-5	42.315	27	9.165	59	2.579	91	0.890	123	0.360
-36	258.740	-4	40.149	28	8.777	60	2.488	92	0.863	124	0.351
-35	242.590	-3	38.107	29	8.408	61	2.400	93	0.838	125	0.342
-34	227.550	-2	36.181	30	8.057	62	2.316	94	0.813	126	0.333
-33	213.550	-1	34.364	31	7.722	63	2.235	95	0.789	127	0.325
-32	200.510	0	32.650	32	7.402	64	2.158	96	0.765	128	0.317
-31	188.340	1	31.027	33	7.098	65	2.083	97	0.743	129	0.309
-30	177.000	2	29.495	34	6.808	66	2.011	98	0.721	130	0.301
-29	166.350	3	28.048	35	6.531	67	1.943	99	0.700	131	0.293
-28	156.410	4	26.680	36	6.267	68	1.877	100	0.680	132	0.286
-27	147.140	5	25.388	37	6.016	69	1.813	101	0.661	133	0.279
-26	138.470	6	24.165	38	5.775	70	1.752	102	0.642	134	0.272
-25	130.370	7	23.009	39	5.546	71	1.694	103	0.623	135	0.265
-24	122.800	8	21.916	40	5.327	72	1.637	104	0.606	136	0.259
-23	115.720	9	20.880	41	5.117	73	1.583	105	0.589	137	0.253
-22	109.090	10	19.900	42	4.917	74	1.531	106	0.572	138	0.247
-21	102.880	11	18.969	43	4.726	75	1.481	107	0.556	139	0.241
-20	97.070	12	18.087	44	4.543	76	1.433	108	0.541	140	0.235
-19	91.600	13	17.251	45	4.369	77	1.387	109	0.526	141	0.229
-18	86.474	14	16.459	46	4.202	78	1.342	110	0.511	142	0.224
-17	81.668	15	15.708	47	4.042	79	1.299	111	0.497	143	0.219
-16	77.160	16	14.995	48	3.889	80	1.258	112	0.484	144	0.213
-15	72.929	17	14.319	49	3.743	81	1.218	113	0.471	145	0.208
-14	68.958	18	13.678	50	3.603	82	1.180	114	0.458	146	0.204
-13	65.227	19	13.069	51	3.469	83	1.143	115	0.445	147	0.199
-12	61.722	20	12.490	52	3.340	84	1.107	116	0.434	148	0.194
-11	58.428	21	11.940	53	3.217	85	1.072	117	0.422	149	0.190
-10	55.330	22	11.418	54	3.099	86	1.039	118	0.411	150	0.185
-9	52.402	23	10.921	55	2.986	87	1.007	119	0.400		

## Checking the temperature sensors (cont.)

### Indoor unit: Viessmann NTC 20 k $\Omega$ (orange marking)

$\vartheta$ / °C	R / k $\Omega$	$\vartheta$ / °C	R / k $\Omega$	$\vartheta$ / °C	R / k $\Omega$	$\vartheta$ / °C	R / k $\Omega$	$\vartheta$ / °C	R / k $\Omega$	$\vartheta$ / °C	R / k $\Omega$
-40	702.156	10	40.034	60	4.943	110	1.009	165	0.259	215	0.097
-35	503.154	15	31.537	65	4.136	115	0.879	170	0.233	220	0.089
-30	364.902	20	25.027	70	3.478	120	0.768	175	0.209	225	0.081
-25	257.655	25	20.000	75	2.937	125	0.673	180	0.189	230	0.075
-20	198.442	30	16.090	80	2.492	130	0.592	185	0.171	235	0.069
-15	148.362	35	13.028	85	2.123	135	0.522	190	0.154	240	0.063
-10	112.403	40	10.613	90	1.816	140	0.461	195	0.140	245	0.058
-5	85.788	45	8.696	95	1.559	145	0.409	200	0.127	250	0.054
0	66.048	50	7.166	100	1.34	150	0.364	205	0.116	255	0.050
5	51.214	55	5.936	105	1.16	160	0.289	210	0.106	260	0.046

## Checking the temperature sensors (cont.)

### Indoor unit: Viessmann Pt500A (green marking)

$\vartheta / ^\circ\text{C}$	R / $\Omega$	$\vartheta / ^\circ\text{C}$	R / $\Omega$	$\vartheta / ^\circ\text{C}$	R / $\Omega$	$\vartheta / ^\circ\text{C}$	R / $\Omega$	$\vartheta / ^\circ\text{C}$	R / $\Omega$	$\vartheta / ^\circ\text{C}$	R / $\Omega$
-30	441.1	1	502.0	32	562.3	63	623.9	94	681.2	125	739.8
-29	443.1	2	503.9	33	564.2	64	622.0	95	683.1	126	741.7
-28	445.1	3	505.9	34	566.1	65	625.8	96	685.0	127	743.5
-27	447.0	4	507.8	35	568.1	66	627.7	97	686.9	128	745.4
-26	449.0	5	509.8	36	570.0	67	629.7	98	688.8	129	747.3
-25	451.0	6	511.7	37	571.9	68	631.6	99	690.7	130	749.2
-24	453.0	7	513.7	38	573.9	69	633.5	100	692.6	131	751.1
-23	454.9	8	515.6	39	575.8	70	635.4	101	694.4	132	752.9
-22	456.9	9	517.6	40	577.7	71	637.3	102	696.3	133	754.8
-21	458.9	10	519.5	41	579.7	72	639.2	103	698.2	134	756.7
-20	460.8	11	521.5	42	581.6	73	641.1	104	700.1	135	758.6
-19	462.8	12	523.4	43	583.5	74	643.1	105	702.0	136	760.4
-18	464.8	13	525.4	44	585.4	75	645.0	106	703.9	137	762.3
-17	466.7	14	527.3	45	587.4	76	646.9	107	705.8	138	764.2
-16	468.7	15	529.3	46	589.3	77	648.8	108	707.7	139	766.1
-15	470.6	16	531.2	47	591.2	78	650.7	109	709.6	140	767.9
-14	472.6	17	533.2	48	593.2	79	652.6	110	711.5	141	769.8
-13	474.6	18	535.1	49	595.1	80	654.5	111	713.4	142	771.7
-12	476.5	19	537.0	50	597.0	81	656.4	112	715.3	143	773.6
-11	478.5	20	539.0	51	598.9	82	658.3	113	717.2	144	775.4
-10	480.5	21	540.9	52	600.9	83	660.2	114	719.0	145	777.3
-9	482.4	22	542.9	53	602.8	84	662.1	115	720.9	146	779.2
-8	484.4	23	544.8	54	604.7	85	664.0	116	722.8	147	781.0
-7	486.3	24	546.8	55	606.6	86	665.9	117	724.7	148	782.9
-6	488.3	25	548.7	56	608.6	87	667.9	118	726.6	149	784.8
-5	490.2	26	550.6	57	610.5	88	669.8	119	728.5	150	786.7
-4	492.2	27	552.6	58	612.4	89	671.7	120	730.4	151	788.5
-3	494.2	28	554.5	59	614.0	90	673.6	121	732.2	152	790.4
-2	496.1	29	556.5	60	616.2	91	675.5	122	734.1	153	792.3
-1	498.1	30	558.4	61	618.2	92	677.4	123	736.0	154	794.1
0	500.0	31	560.3	62	620.1	93	679.3	124	737.9	155	796.0

## Checking the temperature sensors (cont.)

### Outdoor unit: Viessmann NTC 10 k $\Omega$ (no marking)

$\vartheta$ / °C	R / k $\Omega$	$\vartheta$ / °C	R / k $\Omega$	$\vartheta$ / °C	R / k $\Omega$	$\vartheta$ / °C	R / k $\Omega$	$\vartheta$ / °C	R / k $\Omega$	$\vartheta$ / °C	R / k $\Omega$
-40	325.700	-8	49.530	24	10.450	56	2.874	88	0.975	120	0.391
-39	305.400	-7	46.960	25	10.000	57	2.770	89	0.946	121	0.381
-38	286.500	-6	44.540	26	9.572	58	2.671	90	0.917	122	0.371
-37	268.800	-5	42.250	27	9.164	59	2.576	91	0.889	123	0.362
-36	252.300	-4	40.100	28	8.776	60	2.484	92	0.863	124	0.352
-35	236.900	-3	38.070	29	8.406	61	2.397	93	0.837	125	0.343
-34	222.600	-2	36.150	30	8.054	62	2.313	94	0.812	126	0.335
-33	209.100	-1	34.340	31	7.719	63	2.232	95	0.788	127	0.326
-32	196.600	0	32.630	32	7.399	64	2.155	96	0.765	128	0.318
-31	184.900	1	31.020	33	7.095	65	2.080	97	0.743	129	0.310
-30	173.900	2	29.490	34	6.804	66	2.009	98	0.721	130	0.302
-29	163.700	3	28.050	35	6.527	67	1.940	99	0.700	131	0.295
-28	154.100	4	26.680	36	6.263	68	1.874	100	0.680	132	0.288
-27	145.100	5	25.390	37	6.011	69	1.811	101	0.661	133	0.281
-26	136.700	6	24.170	38	5.770	70	1.750	102	0.642	134	0.274
-25	128.800	7	23.020	39	5.541	71	1.692	103	0.624	135	0.267
-24	121.400	8	21.920	40	5.321	72	1.636	104	0.606	136	0.261
-23	114.500	9	20.890	41	5.112	73	1.581	105	0.589	137	0.254
-22	108.000	10	19.910	42	4.912	74	1.529	106	0.573	138	0.248
-21	102.000	11	18.980	43	4.720	75	1.479	107	0.557	139	0.242
-20	96.260	12	18.100	44	4.538	76	1.431	108	0.541	140	0.237
-19	90.910	13	17.260	45	4.363	77	1.385	109	0.527	141	0.231
-18	85.880	14	16.470	46	4.196	78	1.340	110	0.512	142	0.226
-17	81.160	15	15.720	47	4.036	79	1.297	111	0.498	143	0.220
-16	76.720	16	15.000	48	3.884	80	1.256	112	0.485	144	0.215
-15	72.560	17	14.330	49	3.737	81	1.216	113	0.472	145	0.210
-14	68.640	18	13.690	50	3.597	82	1.178	114	0.459	146	0.206
-13	64.950	19	13.080	51	3.463	83	1.141	115	0.447	147	0.201
-12	61.480	20	12.500	52	3.335	84	1.105	116	0.435	148	0.196
-11	58.220	21	11.940	53	3.212	85	1.071	117	0.423	149	0.192
-10	55.150	22	11.420	54	3.095	86	1.038	118	0.412	150	0.187
-9	52.250	23	10.920	55	2.982	87	1.006	119	0.401		

## Checking the fuses

Fuse locations:

- Indoor unit:  
See page 36 onwards.
- Outdoor unit:  
See page 48 onwards.

### Checking the fuses (cont.)

- Fuse F1 is located on the mains terminal of the heat pump control unit.  
Fuse type:
  - 6.3 A H (slow), 250 V~
  - Max. power loss  $\leq 2.5$  W
- Fuse F3 is located on the main PCB.  
Fuse type:
  - 2.0 A H (slow), 250 V~
  - Max. power loss  $\leq 2.5$  W
- The fuses for the fan and the refrigerant circuit controller are located in the outdoor unit above the EEV PCB.

1. Switch OFF the power supply.
2. Opening the wiring chamber.
3. Check fuses. Replace if necessary.



#### **Danger**

Incorrect or improperly fitted fuses can lead to an increased risk of fire.

- Insert fuses without using any force. Position fuses correctly.
- Only use structurally identical types with the same response characteristics.



#### **Danger**

Removing the fuse does **not switch the power circuit to zero volt**. Contact with 'live' components can lead to serious injury from electric current.

Before working on the equipment, always ensure that **the power circuit is also at zero volt**.



## Hydraulic parameter report

Settings and test values	Set value	Commissioning	Maintenance/ service
<b>Checking external heating circuit pumps</b>			
Circulation pump type			
Circulation pump stage			
Overflow valve setting			
<b>Commissioning, primary circuit</b>			
Air intake temperature ("Diagnosis" → "System overview")	°C		
Air discharge temperature ("Diagnosis" → "System overview")	°C		
Temperature differential (air intake/ discharge) $\Delta T$ :			
▪ At secondary circuit flow temperature = 35 °C and air intake temperature ≤ 15 °C	K	4 to 8	
▪ At secondary circuit flow temperature = 35 °C and air intake temperature > 15 °C	K	4 to 13	
<b>Checking mixer, heat pump and cylinder heating</b>			
Checked under the following conditions:			
Room temperature	°C		
Outside temperature	°C		
Temperature "Cylinder temp. top" constant?		Yes ( $\pm 1$ K)	
Secondary circuit flow temperature	°C	Rising	From To From To
Temperature differential $\Delta T$ "Flow temp. secondary" / "Return temp. sec."	K	6 to 8	

## Control parameter report

 **Parameter description**  
"Vitotronic 200" service instructions

### System definition

Parameter	Code	Factory setting	Commissioning	Maintenance/ service
System scheme (see chapter "System scheme")	7000	2		
Interval for long term average outside temperature	7002	180 min.		
Temperature differential for calculating the heating limit	7003	40 ( $\pm 4$ K)		
Temperature differential for calculating the cooling limit	7004	40 ( $\pm 4$ K)		
Swimming pool	7008	0		
Enable flow temperature sensor cooling circuit	7009	Do not adjust.		
Cascade control	700A	0		

**Control parameter report** (cont.)

Parameter	Code	Factory setting	Commissioning	Maintenance/service
Use of heat pump in cascade	700C	2		
Runtime balance cascade	700D	1		
Output control strategy, cascade	700F	0		
External extension	7010	0		
System components for external changeover	7011	0		
Operating status for external changeover	7012	2		
Duration of external changeover	7013	8 h		
Effect of external demand on heat pump/heating circuits	7014	4		
Effect of ext. blocking on heat pump/heating circuits	7015	4		
Vitocom 100 (type GSM/GSM2 only)	7017	0		
Temperature range input 0..10V	7018	1000 ( $\pm$ 10 V)		
Priority external demand	7019	0		
Effect of external blocking on pumps/compressor	701A	0		
Common system flow temperature sensor	701B	0		
Operating status after message A9, C9	701C	0		
Effect of OM changeover to ventilation	701F	3		
Number of lag heat pumps	7029	0		
Holiday program effect	7050	384		

**Compressor**

Parameter	Code	Delivered condition	Commissioning	Maintenance/service
Enable compressor	5000	1		
Evaporator temperature for defrost end	5010	Automatically preset		
Enable use of compressor stage	5012	15		
Output compressor stage	5030	Rated heating output according to type plate		

**Control parameter report** (cont.)**External heat generator**

Parameter	Code	Delivered condition	Commissioning	Maintenance/service
Enable external heat source	7B00	0		
Priority ext. heat source/instant. heating water heater	7B01	1		
Dual mode temperature external heat source	7B02	100 ( $\pm 10$ °C)		
Start threshold external heat source	7B03	300 ( $\pm 30$ min)		
Start delay external heat source	7B04	30 min		
Min. flow temperature mixer external heat source ON	7B05	0		
Min. runtime external heat source	7B06	20 min		
Run-on time external heat source	7B07	10 min		
Max. excess flow temp external heat source	7B0B	0		
Enable external heat gen. for central heating	7B0C	1		
Enable external heat source for DHW heating	7B0D	0		
Dual mode heat pump operation	7B0E	1		
Shutdown limit, heat pump dual mode	7B0F	-500 ( $\pm -50$ °C)		
Enable min. temp. maintenance for ext. HS	7B10	0		
Enable boiler water temperature sensor	7B11	1		
Fuel	7B7F	0		
Appliance control strategy	7BE1	2		
Primary energy factor, electricity	7BE4	260 ( $\pm 2.6$ )		
Primary energy factor, fossil	7BE5	110 ( $\pm 1.1$ )		
Electr. price, standard tariff	7BE8	0 (100 $\pm 1$ ct/kWh)		
Electr. price, premium tariff	7BE9	0 (100 $\pm 1$ ct/kWh)		
Electricity price, low tariff	7BEA	0 (100 $\pm 1$ ct/kWh)		
Fossil fuel price, standard tariff	7BEB	0 (100 $\pm 1$ ct/kWh)		
Electricity price, on-site energy consumption	7BED	1300 ( $\pm -13$ ct/kWh)		

**Control parameter report** (cont.)**DHW**

Parameter	Code	Delivered condition	Commissioning	Maintenance/service
Set DHW temperature	6000	500 ( $\pm$ 50 °C)		
Min. DHW temperature	6005	100 ( $\pm$ 10 °C)		
Max. DHW temperature	6006	600 ( $\pm$ 60 °C)		
Hysteresis DHW temperature heat pump	6007	50 ( $\pm$ 5 K)		
Hysteresis DHW temperature booster heater	6008	100 ( $\pm$ 10 K)		
Start optimisation for DHW heating	6009	0		
Stop optimisation for DHW heating	600A	0		
Set DHW temperature 2	600C	600 ( $\pm$ 60 °C)		
Temperature rise per hour for DHW heating	600D	30 K/h		
Temperature sensor at bottom of DHW cylinder	600E	0		
Max. runtime DHW heating in heating mode	6011	240 min		
Max. interruption of DHW heating for central heating	6012	90 min		
Enable booster heaters for DHW heating	6014	0		
Enable electric heaters for DHW heating	6015	1		
Priority DHW heating with combi cylinder	6016	0		
Start attempts for DHW after high pressure shutdown	6017	1		
Shutdown hysteresis inst. heating water heater	601E	10 ( $\pm$ 1 K)		
Enable elec. heating/ext. HS for reheating only	6040	0		
DHW heating blocking time	6060	0 min		
Max. interruption, DHW heating	6061	0 min		

**Solar**

Parameter	Code	Delivered condition	Commissioning	Maintenance/Service
"Type solar control unit"	7A00	0		
Parameters for solar control module, type SM1	C0xx	These parameters will only be displayed if the solar control module, type SM1, is connected to the heat pump and "Type solar control unit" is set to "3". For a description of the parameters, see installation and service instructions for "solar control module, type SM1".		

**Control parameter report** (cont.)**Electric booster heater**

Parameter	Code	Delivered condition	Commissioning	Maintenance/service
"Enable instantaneous heating water heater"	7900	1		
"Enable electric heaters for DHW heating"	7901	0		
"Enable instant. heating water heater for central heating"	7902	0		
"Start delay instantaneous heating water heater"	7905	30 min		
"Max. output instantaneous heating water heater"	7907	3		
"Output for instant. heating water heater at power-OFF"	790A	0		
"Dual mode temp. instant. heating water heater"	790B	500 ( $\pm$ 50 °C)		

**Internal hydraulics**

Parameter	Code	Factory setting	Commissioning	Maintenance/service
Heat pump for drying a building	7300	0		
Time program for screed drying	7303	0		
Set flow temperature external demand	730C	500 ( $\pm$ 50 °C)		
Start threshold	730E	300 ( $\pm$ 30 K·min)		
Compressor performance at min. outside temperature	730F	50 %		
Compressor performance at max. outside temperature	7310	20 %		
Cooling start threshold	7311	100 ( $\pm$ 10 K·min)		
Elec. heater start threshold	7312	300 ( $\pm$ 30 K·min)		
Cycle rate heating circuit pumps	7319	0		
Secondary circuit pump type	735A	0		
Starting time high efficiency circulation pump	7365	Do not adjust.		
Screed program start day	7378	1		
Screed program end day	7379	31		

**Primary source**

Parameter	Code	Delivered condition	Commissioning	Maintenance/service
"Primary source ctrl strategy"	7401	Never adjust		

**Control parameter report** (cont.)**Buffer cylinder**

Parameter	Code	Delivered condition	Commissioning	Maintenance/service
Enable buffer cylinder/low loss header	7200	0		
Temp in operating status fixed value for buffer cyl	7202	500 ( $\pm$ 50 °C)		
Hysteresis temperature heating buffer cylinder	7203	50 ( $\pm$ 5 K)		
Max. temperature buffer cylinder	7204	600 ( $\pm$ 60 °C)		
Stop optimisation heating buffer cylinder	7205	0		
Temp limit op. status fixed value for buffer cylinder	7208	500 ( $\pm$ 50 °C)		
Stop hysteresis, heating water buffer cylinder	7209	0 ( $\pm$ 0 K)		
Operating mode, fixed value only for heat demand	720A	0		
Temp in op. status. fixed value for coolant buff cyl.	7220	200 ( $\pm$ 20 °C)		
Stop hysteresis coolant buffer cylinder	7223	20 ( $\pm$ 2 K)		
Min. temperature coolant buffer cylinder	722A	40 ( $\pm$ 4 °C)		
Start hysteresis coolant buffer cylinder	722B	50 ( $\pm$ 5 °C)		

**Heating circuit 1**

Parameter	Code	Factory setting	Commissioning	Maintenance/service
Standard room temperature	2000	200 ( $\pm$ 20 °C)		
Reduced room temperature	2001	160 ( $\pm$ 16 °C)		
Remote control	2003	0		
Room temperature control	2005	0		
Heating curve level	2006	0 ( $\pm$ 0 K)		
Heating curve slope	2007	6 ( $\pm$ 0.6)		
Influence room temperature hook-up	200A	10		
Room temperature hook-up	200B	0		
Max. flow temperature heating circuit	200E	400 ( $\pm$ 40 °C)		
Room temperature in party mode	2022	200 ( $\pm$ 20 °C)		
Cooling	2030	0		
Dew point monitor	2031	1		
Min. flow temperature cooling	2033	200 ( $\pm$ 20 °C)		
Influence room temperature hook-up cooling circuit	2034	0		
Hysteresis room temp cooling circuit	2037	10		
Cooling curve level	2040	0		
Cooling curve slope	2041	12		

**Control parameter report** (cont.)**Heating circuit 2**

Parameter	Code	Factory setting	Commissioning	Maintenance/service
Standard room temperature	3000	200 ( $\pm$ 20 °C)		
Reduced room temperature	3001	160 ( $\pm$ 16 °C)		
Remote control	3003	0		
Room temperature control	3005	0		
Heating curve level	3006	0 ( $\pm$ 0 K)		
Heating curve slope	3007	6 ( $\pm$ 0.6)		
Influence room temperature hook-up	300A	10		
Room temperature hook-up	300B	0		
Max. flow temperature heating circuit	300E	400 ( $\pm$ 40 °C)		
Runtime mixer heating circ	3015	Do not adjust.		
Room temperature in party mode	3022	200 ( $\pm$ 20 °C)		
Cooling	3030	0		
Dew point monitor	3031	1		
Min. flow temperature cooling	3033	200 ( $\pm$ 20 °C)		
Influence room temperature hook-up cooling circuit	3034	0		
Hysteresis room temp cooling circuit	3037	10		
Cooling curve level	3040	0		
Cooling curve slope	3041	12		

**Heating circuit 3**

Parameter	Code	Factory setting	Commissioning	Maintenance/service
Standard room temperature	4000	200 ( $\pm$ 20 °C)		
Reduced room temperature	4001	160 ( $\pm$ 16 °C)		
Remote control	4003	0		
Room temperature control	4005	0		
Heating curve level	4006	0 ( $\pm$ 0 K)		
Heating curve slope	4007	6 ( $\pm$ 0.6)		
Influence room temperature hook-up	400A	10		
Room temperature hook-up	400B	0		
Max. flow temperature heating circuit	400E	400 ( $\pm$ 40 °C)		
Runtime mixer heating circ	4015	Do not adjust.		
Room temperature in party mode	4022	200 ( $\pm$ 20 °C)		
Cooling	4030	0		
Dew point monitor	4031	1		
Min. flow temperature cooling	4033	200 ( $\pm$ 20 °C)		
Influence room temperature hook-up cooling circuit	4034	0		
Hysteresis room temp cooling circuit	4037	10		
Cooling curve level	4040	0		
Cooling curve slope	4041	12		

**Control parameter report** (cont.)**Cooling**

Parameter	Code	Delivered condition	Commissioning	Maintenance/service
Cooling function	7100	0		
Cooling circuit	7101	1		
Set room temperature separate cooling circuit	7102	200 ( $\pm$ 20 °C)		
Min. flow temperature cooling	7103	200 ( $\pm$ 20 °C)		
Influence room temperature hook-up cooling circuit	7104	0		
Room temperature control cooling circuit	7105	1		
Ranking room temp sensor separate cooling circuit	7106	0		
Hysteresis room temp cooling circuit	7107	10 ( $\pm$ 1 K)		
Enable flow temperature sensor cooling circuit	7109	1		
Cooling curve level	7110	0 ( $\pm$ 0 K)		
Cooling curve slope	7111	12 ( $\pm$ 1.2)		
Remote control cooling circ	7116	Do not adjust!		
Dew point monitor	7117	1		
Cooling integral start threshold	7118	10 %		
Enable active cooling	71FE	0		

**Ventilation: Vitovent 200-C and Vitovent 300-F**

Parameter	Code	Delivered condition	Commissioning	Maintenance/service
Vitovent enable	7D00	0		
Enable preheater bank electric	7D01	0		
Enable reheater bank hydraulic	7D02	0		
Enable humidity sensor	7D05	0		
Enable CO2 sensor	7D06	0		
Set room temperature	7D08	200 ( $\pm$ 20 °C)		
Flow rate reduced ventilation	7D0A	<ul style="list-style-type: none"> <li>▪ Vitovent 200-C: 75 m<sup>3</sup>/h</li> <li>▪ Vitovent 300-F: 120 m<sup>3</sup>/h</li> </ul>		
Flow rate nominal ventilation	7D0B	<ul style="list-style-type: none"> <li>▪ Vitovent 200-C: 115 m<sup>3</sup>/h</li> <li>▪ Vitovent 300-F: 170 m<sup>3</sup>/h</li> </ul>		
Flow rate intensive ventilation	7D0C	<ul style="list-style-type: none"> <li>▪ Vitovent 200-C: 155 m<sup>3</sup>/h</li> <li>▪ Vitovent 300-F: 215 m<sup>3</sup>/h</li> </ul>		
Min. supply air temperature for bypass	7D0F	160 ( $\pm$ 16 °C)		
CO2 value for raising the flow rate	7D18	800 ppm		
Humidity value for raising the flow rate	7D19	65 %		
Interval time frost protection ventilation	7D1A	15 min		
Intensive ventilation duration	7D1B	120 min		
Actual source room temperature	7D1D	1		



**Control parameter report** (cont.)

Parameter	Code	Delivered condition	Commissioning	Maintenance/service
Heating circuit for blocking bypass damper	7D21	7		
Control voltage matching	7D27	0 ( $\pm$ 0 V)		
Fan for control voltage matching	7D28	0		
Strategy, passive frost protection	7D2C	0		
Type of heat exchanger	7D2E	0		
Installation position	7D2F	0		
Function, external 230 V input, ventilation	7D3A	0		
Duration, bathroom vent.	7D3B	30 min		
Starting block, ventilation periods part 1	7D5E	0		
Starting block, ventilation periods part 2	7D5F	0		
Control voltage matching, supply air fan	7D71	0 V		
Control voltage matching, exhaust air fan	7D72	0 V		
Sensor matching, outdoor air temperature	7D75	0 K		
Sensor matching, outdoor air temp after pre-heating coil	7D76	0 K		
Sensor matching, supply air temperature	7D77	0 K		
Sensor matching, extract air temperature	7D79	0 K		
Delay, subs. failure ventilation	7D90	0 min		

**Ventilation: Vitovent 200-W, Vitovent 300-C and Vitovent 300-W**

Parameter	Code	Delivered condition	Commissioning	Maintenance/service
Vitovent enable	7D00	0		
Heating circuit for blocking bypass damper	7D21	7		
Delay, subs. failure ventilation	7D90	0 min		
Preheating coil	C101	1		
Reheater	C102	0		
Humidity sensor	C105	0		
Set CO2 value	C106	0		
Set room temperature	C108	22 ( $\pm$ 2 °C)		
Background ventilation	C109	<ul style="list-style-type: none"> <li>▪ Vitovent 200-W: 15 %</li> <li>▪ Vitovent 300-C: 30 m<sup>3</sup>/h</li> <li>▪ Vitovent 300-W: 50 m<sup>3</sup>/h</li> </ul>		
Reduced ventilation	C10A	<ul style="list-style-type: none"> <li>▪ Vitovent 200-W: 25 %</li> <li>▪ Vitovent 300-C: 75 m<sup>3</sup>/h</li> <li>▪ Vitovent 300-W: 100 m<sup>3</sup>/h</li> </ul>		
Standard ventilation	C10B	<ul style="list-style-type: none"> <li>▪ Vitovent 200-W: 50 %</li> <li>▪ Vitovent 300-C: 100 m<sup>3</sup>/h</li> <li>▪ Vitovent 300-W: 150 m<sup>3</sup>/h</li> </ul>		

**Control parameter report** (cont.)

Parameter	Code	Delivered condition	Commissioning	Maintenance/service
Intensive ventilation	C10C	<ul style="list-style-type: none"> <li>▪ Vitovent 200-W: 75 %</li> <li>▪ Vitovent 300-C: 125 m<sup>3</sup>/h</li> <li>▪ Vitovent 300-W: 225 m<sup>3</sup>/h</li> </ul>		
Background ventilation, second fan duct	C189	15 %		
Reduced ventilation, second fan duct	C18A	25 %		
Standard ventilation, second fan duct	C18B	50 %		
Intensive ventilation, second fan duct	C18C	75 %		
Bypass mode	C1A0	0		
Central heating and heat recovery	C1A1	0		
Imbalance permitted	C1A2	1		
Specified imbalance	C1A3	0		
Set reheater coil temperature	C1A4	210 ( $\pm$ 21 °C)		
Humidity sensor sensitivity	C1A6	0		
Min. temperature, geothermal heat exchanger	C1AA	50 ( $\pm$ 5 °C)		
Max. temperature, geothermal heat exchanger	C1AB	250 ( $\pm$ 25 °C)		
Function, input 1	C1B0	0		
Min. voltage, input 1	C1B1	0 (10 $\pm$ 1 V)		
Min. voltage, input 2	C1C1	0 (10 $\pm$ 1 V)		
Flow rate correction	C1C7	100		

**Note**

The factory settings of parameters C101 to C1C7 depend on the ventilation unit and may differ from the values specified here. The factory setting is displayed in the service menu for each parameter with "**Del con ...**": "▼" See "Vitotronic 200 service instructions".

**Control parameter report** (cont.)**Photovoltaics**

Parameter	Code	Factory setting	Commissioning	Maintenance/service
Enable own energy consumption PV	7E00	0		
Prop. of external current	7E02	10 ( $\pm$ 10 %)		
Threshold for electrical power	7E04	0 ( $\pm$ 0 W)		
Stop threshold (relative)	7E07	0 ( $\pm$ 0 kW)		
Enable own energy consumptn for set DHW temperature 2	7E10	0		
Enable own energy consumption for DHW heating	7E11	0		
Enable own energy consumptn for heating water buffer cyl.	7E12	0		
Enable own energy consumption for heating	7E13	0		
Enable own energy consumption for cooling	7E15	0		
Enable own energy consumptn for coolant buffer cylinder	7E16	0		
Raise set DHW cylinder temperature PV	7E21	0 ( $\pm$ 0 K)		
Raise set heating water buffer cylinder temp PV	7E22	0 ( $\pm$ 0 K)		
Raise set room temperature PV	7E23	0 ( $\pm$ 0 K)		
Reduce set room temperature PV	7E25	0 ( $\pm$ 0 K)		
Reduce set coolant buffer cylinder temperature PV	7E26	0		

**Smart Grid**

Parameter	Code	Delivered condition	Commissioning	Maintenance/Service
"Enable Smart Grid"	7E80	0		
"Smart Grid Enable elec heat"	7E82	0		
"Smart Grid set value increase for DHW heating"	7E91	0 ( $\pm$ 0 K)		
"Smart Grid set value increase for htg wtr buff"	7E92	0 ( $\pm$ 0 K)		
"Smart Grid set value increase for centr htg"	7E93	0 ( $\pm$ 0 K)		
"Smart Grid set value decrease for room t cool"	7E95	0 ( $\pm$ 0 K)		

**Time**

Parameter	Code	Delivered condition	Commissioning	Maintenance/Service
"Automatic changeover summertime - wintertime"	7C00	1		
"Start summertime - month"	7C01	3		
"Start summertime - week"	7C02	5		
"Start summertime - day"	7C03	7		
"Start wintertime - month"	7C04	10		
"Start wintertime - week"	7C05	5		
"Start wintertime - day"	7C06	7		

**Control parameter report** (cont.)**Communication**

Parameter	Code	Delivered condition	Commissioning	Maintenance/Service
"Number of heat pump in cascade"	7707	1		
"Enable LON communication module"	7710	0		
"LON subscriber number"	7777	1		
"LON fault manager"	7779	0		
"LON system number"	7798	1		
"Interval for data transfer via LON"	779C	20 min		
"Source outside temperature"	77FC	0		
"Send outside temperature"	77FD	0		
"Source time"	77FE	0		
"Send time"	77FF	0		

**Control**

Parameter	Code	Delivered condition	Commissioning	Maintenance/service
"Lock out controls"	8800	0		
"Level enable, time program quieter operation"	8801	0		
"User level for display, energy stmt"	8811	1		

## Specification

## Heat pumps with outdoor unit 230 V

Type AWO-M/AWO-M-E/AWO-M-E-AC		201.A04	201.A06	201.A08	201.A10	201.A13	201.A16
<b>Heating performance data to EN 14511 (A2/W35)</b>							
Rated heating output	kW	2.61	3.11	4.04	5.01	5.92	6.47
Fan speed	rpm	600	600	650	600	600	600
Power consumption	kW	0.73	0.82	1.02	1.27	1.48	1.79
Coefficient of performance $\epsilon$ (COP) in heating mode		3.57	3.78	3.96	3.96	4.01	3.61
Output control	kW	2.0 to 4.1	2.4 to 5.5	2.8 to 7.0	4.4 to 9.6	4.8 to 10.2	5.2 to 10.7
<b>Heating performance data to EN 14511 (A7/W35, 5 K spread)</b>							
Rated heating output	kW	3.96	4.83	5.62	7.01	7.85	8.64
Fan speed	rpm	600	600	650	600	600	600
Air flow rate	m <sup>3</sup> /h	2250	2250	2600	4500	4500	4500
Power consumption	kW	0.87	1.02	1.19	1.49	1.66	1.90
Coefficient of performance $\epsilon$ (COP) in heating mode		4.56	4.72	4.71	4.69	4.72	4.54
Output control	kW	2.4 to 4.2	3.0 to 6.0	3.5 to 7.5	5.5 to 12.6	6.0 to 13.7	6.4 to 14.3
<b>Heating performance data to EN 14511 (A-7/W35)</b>							
Rated heating output	kW	3.81	5.70	6.67	8.69	9.50	11.03
Power consumption	kW	1.31	1.96	2.31	2.77	3.09	3.90
Coefficient of performance $\epsilon$ (COP) in heating mode		2.91	2.91	2.89	3.14	3.07	2.83
<b>Cooling performance data to EN 14511 (A35/W7)</b>							
Rated cooling capacity	kW	2.00	3.00	4.00	5.00	6.00	7.00
Fan speed	rpm	600	600	650	900	900	900
Power consumption	kW	0.83	1.15	1.38	1.85	2.26	2.69
Energy efficiency ratio EER in cooling mode		2.40	2.60	2.90	2.70	2.65	2.60
Output control	kW	Up to 3.9	Up to 4.9	Up to 6.2	Up to 8.0	Up to 9.0	Up to 10.3
<b>Cooling performance data to EN 14511 (A35/W18)</b>							
Rated cooling capacity	kW	4.00	5.00	6.00	7.00	8.20	9.20
Fan speed	rpm	600	600	650	900	900	900
Power consumption	kW	0.95	1.19	1.40	1.71	2.08	2.42
Energy efficiency ratio EER in cooling mode		4.20	4.20	4.30	4.10	3.95	3.80
Output control	kW	Up to 5.0	Up to 6.0	Up to 7.0	Up to 11.0	Up to 12.5	Up to 13.9

# Specification

## Specification (cont.)

Type AWO-M/AWO-M-E/AWO-M-E-AC	201.A04	201.A06	201.A08	201.A10	201.A13	201.A16
<b>Air intake temperature</b>						
Cooling mode (type AWO-M-E-AC only)						
▪ Min.	°C	10	10	10	10	10
▪ Max.	°C	45	45	45	45	45
Heating mode						
▪ Min.	°C	-20	-20	-20	-20	-20
▪ Max.	°C	35	35	35	35	35
<b>Heating water</b> (secondary circuit)						
Minimum flow rate	l/h	700	700	700	1400	1400
Minimum volume in the heating system, cannot be fitted with shut-off devices	l	50	50	50	50	50
Max. external pressure drop (RFH) at minimum flow rate	mbar	700	700	700	500	500
	kPa	70	70	70	50	50
Max. flow temperature	°C	60	60	60	60	60
<b>Outdoor unit electrical values</b>						
Rated voltage, compressor		1/N/PE 230 V/50 Hz				
Max. operating current, compressor	A	13.0	14.6	14.6	19.9	23.3
Cos φ		0.99	0.99	0.99	0.99	0.99
Starting current, compressor	A	5	5	5	5	5
Fuse rating		B16A	B16A	B16A	B25A	B25A
IP rating		IPX4	IPX4	IPX4	IPX4	IPX4
<b>Indoor unit electrical values</b>						
Heat pump control unit/PCB						
▪ Rated voltage		1/N/PE 230 V/50 Hz				
▪ Power supply fuse rating		1 x B16 A	1 x B16 A	1 x B16 A	1 x B16 A	1 x B16 A
▪ Internal fuse		6.3 A (slow)/250 V				
Instantaneous heating water heater						
▪ Type AWO-M-E/AWO-M-E-AC: Factory-fitted						
▪ Type AWO-M: Accessories						
▪ Rated voltage		1/N/PE 230 V/50 Hz or 3/N/PE 400 V/50 Hz				
▪ Heating output	kW	9	9	9	9	9
▪ Power supply fuse rating		3 x B16 A	3 x B16 A	3 x B16 A	3 x B16 A	3 x B16 A

## Specification (cont.)

Type AWO-M/AWO-M-E/AWO-M-E-AC		201.A04	201.A06	201.A08	201.A10	201.A13	201.A16
<b>Max. power consumption</b>							
Fan	W	45	45	115	2 x 115	2 x 115	2 x 115
Outdoor unit	kW	2.85	3.20	3.30	4.55	5.08	5.08
Secondary pump (PWM)	W	60	60	60	60	60	60
▪ Energy efficiency index EEI		≤ 0.2	≤ 0.2	≤ 0.2	≤ 0.2	≤ 0.2	≤ 0.2
Control unit/PCB, outdoor unit	W	15	15	15	15	15	15
Control unit/PCB, indoor unit	W	10	10	10	10	10	10
Control unit/PCB power, indoor unit	W	1000	1000	1000	1000	1000	1000
<b>Refrigerant circuit</b>							
Refrigerant		R410A	R410A	R410A	R410A	R410A	R410A
▪ Safety assembly		A1	A1	A1	A1	A1	A1
▪ Refrigerant charge	kg	1.40	1.40	1.40	2.40	2.40	2.40
▪ Global warming potential (GWP) <sup>2</sup>		1924	1924	1924	1924	1924	1924
▪ CO <sub>2</sub> equivalent	t	2.7	2.7	2.7	4.6	4.6	4.6
Compressor (hermetically sealed)	Type	Scroll	Scroll	Scroll	Scroll	Scroll	Scroll
▪ Oil in compressor	Type	3 MAF POE	3 MAF POE	3 MAF POE	3 MAF POE	3 MAF POE	3 MAF POE
▪ Oil volume in compressor	l	0.76	0.76	0.76	1.17	1.17	1.17
<b>Permissible operating pressure</b>							
▪ High pressure side	bar	43	43	43	43	43	43
	MPa	4.3	4.3	4.3	4.3	4.3	4.3
▪ Low pressure side	bar	28	28	28	28	28	28
	MPa	2.8	2.8	2.8	2.8	2.8	2.8
<b>Outdoor unit dimensions</b>							
Total length	mm	546	546	546	546	546	546
Total width	mm	1109	1109	1109	1109	1109	1109
Total height	mm	753	753	753	1377	1377	1377
<b>Indoor unit dimensions</b>							
Total length	mm	370	370	370	370	370	370
Total width	mm	450	450	450	450	450	450
Total height	mm	880	880	880	880	880	880
<b>Total weight</b>							
Outdoor unit	kg	102	102	103	145	145	145
Indoor unit							
▪ Type AWO-M	kg	40	40	40	40	40	40
▪ Type AWO-M-E/AWO-M-E-AC	kg	41	41	41	41	41	41
<b>Permissible operating pressure, secondary side</b>							
	bar	3	3	3	3	3	3
	MPa	0.3	0.3	0.3	0.3	0.3	0.3

## Specification

### Specification (cont.)

Type AWO-M/AWO-M-E/AWO-M-E-AC	201.A04	201.A06	201.A08	201.A10	201.A13	201.A16
<b>Connections</b> (female thread)						
Heating water flow G	1¼	1¼	1¼	1¼	1¼	1¼
Heating water return and DHW cylinder return G	1¼	1¼	1¼	1¼	1¼	1¼
DHW cylinder flow G	1¼	1¼	1¼	1¼	1¼	1¼
Secondary circuit flow G	1¼	1¼	1¼	1¼	1¼	1¼
Secondary circuit return G	1¼	1¼	1¼	1¼	1¼	1¼
<b>Length of connection line between indoor — outdoor units</b> (Hydraulic connection set) m	1 to 20	1 to 20	1 to 20	1 to 20	1 to 20	1 to 20
<b>Sound power of outdoor unit</b> at rated heating output (Measurements with reference to EN 12102/ EN ISO 9614-2)						
Weighted total sound power level						
▪ At $A_{7\pm 3 K/W55\pm 5 K}$ (max.) dB(A)	56	56	58	60	61	61
▪ At $A_{7\pm 3 K/W55\pm 5 K}$ in night mode dB(A)	50	50	50	55	55	55
<b>Energy efficiency class</b> to Commission Regulation (EU) No 813/2013						
Heating, average climatic conditions						
▪ Low temperature application (W35)	A <sup>++</sup>	A <sup>++</sup>	A <sup>+++</sup>	A <sup>+++</sup>	A <sup>+++</sup>	A <sup>+++</sup>
▪ Medium temperature application (W55)	A <sup>+</sup>	A <sup>++</sup>	A <sup>++</sup>	A <sup>++</sup>	A <sup>++</sup>	A <sup>++</sup>
<b>Heating performance data</b> as per Commission Regulation (EU) No 813/2013 (average climatic conditions)						
Low temperature application (W35)						
▪ Energy efficiency $\eta_S$ %	173	172	175	176	175	175
▪ Rated heating output $P_{rated}$ kW	5.38	5.59	6.82	9.32	9.99	10.61
▪ Seasonal coefficient of performance (SCOP)	4.40	4.38	4.46	4.47	4.46	4.46
Medium temperature application (W55)						
▪ Energy efficiency $\eta_S$ %	124	125	127	129	130	130
▪ Rated heating output $P_{rated}$ kW	5.23	5.59	6.41	9.35	10.07	10.72
▪ Seasonal coefficient of performance (SCOP)	3.18	3.21	3.25	3.29	3.32	3.34
<b>Sound power level to ErP</b>						
Sound power level, outdoor unit dB(A)	53	54	55	56	56	56



## Specification (cont.)

## Heat pumps with outdoor unit 400 V

Type AWO/AWO-E/AWO-E-AC		201.A10	201.A13	201.A16
<b>Heating performance data to EN 14511 (A2/W35)</b>				
Rated heating output	kW	6.10	6.67	7.02
Fan speed	rpm	600	600	600
Power consumption	kW	1.49	1.64	1.78
Coefficient of performance $\epsilon$ (COP) in heating mode		4.10	4.06	3.94
Output control	kW	4.4 to 10.1	4.8 to 10.7	5.2 to 11.2
<b>Heating performance data to EN 14511 (A7/W35, 5 K spread)</b>				
Rated heating output	kW	7.58	8.88	10.11
Fan speed	rpm	600	600	600
Air flow rate	m <sup>3</sup> /h	4500	4500	4500
Power consumption	kW	1.51	1.78	2.04
Coefficient of performance $\epsilon$ (COP) in heating mode		5.01	4.99	4.95
Output control	kW	5.5 to 13.6	5.9 to 14.2	6.4 to 14.7
<b>Heating performance data to EN 14511 (A-7/W35)</b>				
Rated heating output	kW	10.09	11.06	11.60
Power consumption	kW	3.17	3.60	3.87
Coefficient of performance $\epsilon$ (COP) in heating mode		3.18	3.07	3.00
<b>Heating performance data to EN 14511 (A35/W7)</b>				
Rated cooling capacity	kW	5.00	6.00	7.00
Fan speed	rpm	600	600	600
Power consumption	kW	1.85	2.31	2.80
Energy efficiency ratio EER in cooling mode		2.70	2.60	2.50
Output control	kW	Up to 8.0	Up to 9.0	Up to 10.0
<b>Heating performance data to EN 14511 (A35/W18)</b>				
Rated cooling capacity	kW	7.00	8.20	9.20
Fan speed	rpm	600	600	600
Power consumption	kW	1.71	2.00	2.30
Energy efficiency ratio EER in cooling mode		4.10	4.10	4.00
Output control	kW	Up to 8.0	Up to 9.0	Up to 10.0
<b>Air intake temperature</b>				
Cooling mode (type AWO-E-AC only)				
▪ Min.	°C	10	10	10
▪ Max.	°C	45	45	45
Heating mode				
▪ Min.	°C	-20	-20	-20
▪ Max.	°C	35	35	35
<b>Heating water (secondary circuit)</b>				
Minimum flow rate	l/h	1400	1400	1400
Minimum volume in the heating system, cannot be fitted with shut-off devices	l	50	50	50
Max. external pressure drop (RFH) at minimum flow rate	mbar	500	500	500
	kPa	50	50	50
Max. flow temperature	°C	60	60	60



## Specification

### Specification (cont.)

Type AWO/AWO-E/AWO-E-AC		201.A10	201.A13	201.A16
<b>Outdoor unit electrical values</b>				
Rated voltage, compressor		3/N/PE 400 V/50 Hz		
Max. operating current, compressor	A	8.7	8.7	8.7
Cos φ		0.96	0.96	0.96
Starting current, compressor	A	5	5	5
Fuse rating		B16A	B16A	B16A
IP rating		IPX4	IPX4	IPX4
<b>Indoor unit electrical values</b>				
Heat pump control unit/PCB				
▪ Rated voltage		1/N/PE 230 V/50 Hz		
▪ Power supply fuse rating		1 x B16A	1 x B16A	1 x B16A
▪ Internal fuse		6.3 A (slow)/250 V		
Instantaneous heating water heater				
▪ Type AWO-E/AWO-E-AC: Factory-fitted		1/N/PE 230 V/50 Hz		
▪ Type AWO: Accessories		or		
▪ Rated voltage		3/N/PE 400 V/50 Hz		
▪ Heating output	kW	9	9	9
▪ Power supply fuse rating		3 x B16A	3 x B16A	3 x B16A
<b>Max. power consumption</b>				
Fan	W	2 x 45	2 x 45	2 x 45
Outdoor unit	kW	5.13	5.13	5.15
Secondary pump (PWM)	W	60	60	60
▪ Energy efficiency index EEI		≤ 0.2	≤ 0.2	≤ 0.2
Control unit/PCB, outdoor unit	W	15	15	15
Control unit/PCB, indoor unit	W	10	10	10
Control unit/PCB power, indoor unit	W	1000	1000	1000
<b>Refrigerant circuit</b>				
Refrigerant		R410A	R410A	R410A
▪ Safety assembly		A1	A1	A1
▪ Refrigerant charge	kg	2.40	2.40	2.40
▪ Global warming potential (GWP) <sup>*3</sup>		1924	1924	1924
▪ CO <sub>2</sub> equivalent	t	4.6	4.6	4.6
Compressor (hermetically sealed)	Type	Scroll	Scroll	Scroll
▪ Oil in compressor	Type	3 MAF POE	3 MAF POE	3 MAF POE
▪ Quantity of oil in compressor	l	1.17	1.17	1.17
Permissible operating pressure				
▪ High pressure side	bar	43	43	43
	MPa	4.3	4.3	4.3
▪ Low pressure side	bar	28	28	28
	MPa	2.8	2.8	2.8

<sup>\*3</sup> Based on the Fifth Assessment Report of the Intergovernmental Panel on Climate Change (IPCC)

## Specification (cont.)

Type AWO/AWO-E/AWO-E-AC		201.A10	201.A13	201.A16
<b>Outdoor unit dimensions</b>				
Total length	mm	546	546	546
Total width	mm	1109	1109	1109
Total height	mm	1377	1377	1377
<b>Indoor unit dimensions</b>				
Total length	mm	370	370	370
Total width	mm	450	450	450
Total height	mm	880	880	880
<b>Total weight</b>				
Outdoor unit	kg	153	153	153
Indoor unit				
▪ Type AWO	kg	40	40	40
▪ Type AWO-E/AWO-E-AC	kg	41	41	41
<b>Permissible operating pressure, secondary side</b>				
	bar	3	3	3
	MPa	0.3	0.3	0.3
<b>Connections (female thread)</b>				
Heating water flow	G	1¼	1¼	1¼
Heating water return and DHW cylinder return	G	1¼	1¼	1¼
DHW cylinder flow	G	1¼	1¼	1¼
Secondary circuit flow	G	1¼	1¼	1¼
Secondary circuit return	G	1¼	1¼	1¼
<b>Length of connection line between indoor — outdoor units (Hydraulic connection set)</b>				
	m	1 to 20	1 to 20	1 to 20
<b>Sound power of outdoor unit at rated heating output (Measurements with reference to EN 12102/ EN ISO 9614-2)</b>				
Weighted total sound power level				
▪ At $A7^{\pm 3 K}/W55^{\pm 5 K}$ (max.)	dB(A)	61	61	61
▪ At $A7^{\pm 3 K}/W55^{\pm 5 K}$ in night mode	dB(A)	55	55	55
<b>Energy efficiency class to EU Regulation no. 813/2013</b>				
Heating, average climatic conditions				
▪ Low temperature applications (W35)		A+++	A+++	A+++
▪ Medium temperature applications (W55)		A++	A++	A++
<b>Performance data as per EU Regulation no. 813/2013 (average climatic conditions)</b>				
Low temperature applications (W35)				
▪ Energy efficiency $\eta_s$	%	180	182	182
▪ Rated heating output $P_{rated}$	kW	9.75	10.99	11.65
▪ Seasonal coefficient of performance (SCOP)		4.58	4.64	4.62
Medium temperature applications (W55)				
▪ Energy efficiency $\eta_s$	%	132	134	134
▪ Rated heating output $P_{rated}$	kW	9.67	11.00	11.98
▪ Seasonal coefficient of performance (SCOP)		3.37	3.42	3.42
<b>Sound power level to ErP</b>				
Sound power level, outdoor unit	dB(A)	56	56	56

## Commissioning order

Email this request form, together with the system scheme, to your local Viessmann sales office. A competent employee must be present when the system is commissioned.

### System details:

Requester \_\_\_\_\_

System location \_\_\_\_\_  
\_\_\_\_\_  
\_\_\_\_\_

### Checklist:

- Hydraulic scheme for heating system included
- Heating circuits fully installed and filled
- Electrical installation completed
- Hydraulic lines fully thermally insulated
- Installation completed in full up to refrigerant circuit
- All windows and external doors airtight
- Components for cooling mode fully installed (optional)
- Components for ventilation fully installed (optional)
- Components for photovoltaic system fully installed (optional)

### Preferred appointment:

1. Date \_\_\_\_\_  
Time \_\_\_\_\_

2. Date \_\_\_\_\_  
Time \_\_\_\_\_

The work requested from Viessmann will be billed to me/us in accordance with the latest Viessmann pricelist.

Place/date \_\_\_\_\_

Signature \_\_\_\_\_

## Final decommissioning and disposal

Viessmann products can be recycled. Components and substances from the system are not part of ordinary domestic waste.

For decommissioning, isolate the system from the power supply and allow components to cool down where appropriate. All components must be disposed of correctly.

## Declaration of conformity

We, Viessmann Climate Solutions SE,  
D-35108 Allendorf, declare as sole responsible body  
that the named product complies with the European  
directives and supplementary national requirements in  
terms of its design and operational characteristics.

Using the serial number, the Declaration of Conformity  
can be found on the following website:  
**[www.viessmann.co.uk/eu-conformity](http://www.viessmann.co.uk/eu-conformity)**

**Keyword index**

<b>A</b>	
Air discharge.....	15, 16, 17
Air intake.....	15, 16, 17
Air short circuit.....	15
Air vent valve, secondary circuit.....	81, 83
Ambient temperatures.....	28
Anti-vibration mount.....	14
Anti-vibration mounts.....	24
Appliance, starting.....	65
Appliance fuses, checking.....	87
Area cooling system.....	31
<b>B</b>	
BDF valve.....	83
Blocking signal.....	55
Boiler water temperature sensor.....	45, 83
Bracket for wall mounting.....	24
Bracket set.....	13, 23
Breaking capacity.....	40
Buffer outlet temperature sensor.....	45, 83
Buffer temperature sensor.....	44, 83
Bypass, heating water buffer cylinder.....	38
<b>C</b>	
Cable entry.....	10
Cable insertion.....	33, 47
Cable length.....	31, 32, 54, 55
Cable routing.....	33, 47
Cellar shaft.....	14
Checking	
– Fuses.....	87
– Sensors.....	83
Chilled ceiling.....	31
Circulation pump for DHW reheating.....	42, 68
Coding card slot.....	45
Coding level 1.....	65
Commissioning.....	61, 65, 108
Commissioning assistant.....	65
Commissioning order.....	108
Commissioning report.....	61
Communication module, LON.....	45
Components.....	37, 40
Compressor.....	13, 81, 83
Concrete foundations.....	23
Condensate.....	14
Condensate drain.....	14, 20, 21, 22, 23, 24
Connected load.....	40
Connecting cable, indoor/outdoor unit.....	31
Connecting cables.....	20, 21, 22, 24, 31
Connection	
– Cooling circuit.....	31
– Electric.....	31
– Electrical components.....	31
– Overview.....	10
– Secondary circuit.....	30
Connection, indoor/outdoor unit.....	49
Connection conditions.....	51
Connection values.....	40
Contact humidistat.....	31, 44
– Connecting.....	44
Contactor relay.....	56
Controller PCB.....	44
Control parameter reports.....	89
Control unit panel.....	79
Cooling.....	37
Cooling circuit, connecting.....	31
Cooling function.....	70
Cooling water flow.....	31
Cover of outdoor unit, fitting.....	59
Cover of programming unit, removal.....	78
Cylinder temperature sensor.....	44, 83
<b>D</b>	
Defrosting.....	15
Design casing.....	20, 22, 24
DHW circulation pump.....	38, 68
DHW cylinder, flow/return.....	30
DHW cylinder return.....	10
Dimensions.....	10
– Indoor unit.....	103, 107
– Outdoor unit.....	103, 107
Diverter valve.....	81, 83
Drain & fill valve, secondary circuit.....	80
Drain for condensate.....	20, 21, 22, 24
Drain hose, safety valve.....	30
Draining secondary circuit.....	83
Drain valve.....	80
<b>E</b>	
EA1 extension.....	45
Economy tariff.....	53
Economy tariff meter.....	55, 56
Electrical connection	
– Cable insertion.....	47
– Indoor unit.....	36
– Outdoor unit.....	48
– Pumps.....	37
– Routing cables.....	33
– Sensors.....	44
Electrical connections	
– Checking.....	62
– Checking the outdoor unit.....	64
– Overview.....	78
Electrical terminal areas.....	36, 48
Electrical values	
– Indoor unit.....	102, 106
– Outdoor unit.....	102, 106
Electric booster heater.....	71
Electric cables.....	20, 22, 24
Electric heater.....	37, 42
Electric ribbon heater.....	14
Electronic expansion valve.....	81, 82
Energy meter.....	45
Evaporator.....	81, 82
Evaporator temperature sensor.....	81, 83
Expansion PCB.....	40
Expansion vessel.....	62
Extended menu.....	67
External extension.....	69

## Keyword index (cont.)

- External functions.....69  
 External heat generator.....72
- F**  
 Fan..... 63, 81, 82  
 Feed..... 51  
 Filling the secondary circuit.....62  
 Fill water.....62  
 Fixing materials..... 13  
 Flat roof installation..... 13  
 – Substructure..... 13  
 Floorstanding installation..... 17  
 Floorstanding installation, outdoor unit..... 23  
 Flow, DHW cylinder..... 10, 104, 107  
 Flow, DHW cylinder/heating water..... 30  
 Flow, outdoor unit.....30  
 Flow switch.....80  
 Flow temperature sensor  
 – Cooling circuit.....45, 83  
 – Heating circuit with mixer..... 44  
 – Secondary circuit.....80, 83  
 – Swimming pool.....45  
 – System..... 45, 83  
 Foundation..... 18, 19, 20, 21, 22  
 Free running of fan, checking.....63  
 Freestanding siting..... 13  
 Front panel..... 59  
 Frost protection for foundations..... 18, 19, 20, 21, 22  
 Frost stat..... 44  
 Function check..... 77  
 Function test.....76  
 Fuse..... 87  
 – F1.....88  
 – F3.....88  
 – Max. power loss..... 88  
 Fuse rating..... 32, 54, 55
- G**  
 Gravel bed for condensate..... 18, 19, 23, 24
- H**  
 Heat exchanger cleaning..... 64  
 Heating circuit pump..... 38, 68  
 Heating performance data..... 101, 105  
 Heating water buffer cylinder bypass..... 38  
 Heating water flow..... 10, 30, 104, 107  
 Heating water return..... 10, 30, 104, 107  
 Heat pump  
 – Checking for noise..... 76  
 – Closing..... 59, 64  
 – Opening.....61  
 – Starting.....65  
 Heat pump cascade..... 76  
 – Minimum clearances..... 16  
 – Power-OFF signal connection.....56  
 Heat pump control unit  
 – Power cable..... 32  
 High limit safety cut-out.....41, 77, 80  
 High pressure fault..... 15  
 High pressure switch.....83
- Hot gas temperature sensor.....81, 83  
 Hydraulic parameters..... 89
- I**  
 Immersion heater..... 42, 72  
 Indoor unit  
 – Cable lengths..... 31  
 – Closing..... 59  
 – Dimensions..... 10, 103, 107  
 – Electrical connection..... 36  
 – Electrical values..... 102, 106  
 – Installation.....27  
 – Instantaneous heating water heater power supply..51  
 – Internal components.....80  
 – Siting.....28  
 – Transport.....27  
 – Wall mounting.....28  
 Inspection.....61  
 Installation  
 – Indoor unit..... 27  
 – Outdoor unit..... 13  
 Installation, outdoor unit  
 – Bracket set for wall mounting..... 13  
 – Supports for floorstanding installation..... 13  
 Installation information..... 13  
 Installation location requirements  
 – Indoor unit..... 28  
 Instantaneous heating water heater.....37, 42, 71, 80  
 – Power cable..... 32  
 – Power supply.....51  
 – Resetting the high limit safety cut-out..... 77  
 – Specification..... 102, 106  
 Instructing the system user..... 77  
 Intended use..... 7  
 Internal components.....80  
 Isolators.....50
- K**  
 KM-BUS distributor..... 45
- L**  
 Lag heat pump..... 56  
 Layout, heat pump cascade..... 16  
 Lead heat pump..... 56  
 Lightning protection..... 14
- M**  
 Main MCB/fuse, switching on..... 64  
 Mains isolator..... 56, 64, 80  
 Maintenance.....61  
 Max. connection line length..... 104, 107  
 Max. tilting angle..... 13  
 Maximum temperature limiter.....38  
 Minimum clearances  
 – Heat pump cascade..... 16  
 – Indoor unit..... 28  
 – Outdoor unit..... 15  
 Mixer extension kit..... 39, 45, 68  
 Modbus cable.....31

Modbus connection.....	49	PCB	
Modbus distributor.....	45	– Controller and sensor PCB.....	44
<b>O</b>		– Expansion PCB.....	40
ON/OFF switch.....	65	– Luster terminals.....	43
On-site connections.....	10	– Main PCB.....	37
Operating noise.....	76	Photovoltaics.....	75
Outdoor unit		Power cable.....	31, 32
– Cable lengths.....	31	– Heat pump control unit.....	51
– Cleaning.....	64	– Indoor unit.....	32
– Closing.....	59	– Outdoor unit.....	32
– Dimensions.....	11, 103, 107	Power circuits.....	51
– Electrical connection.....	48	Power consumption.....	103, 106
– Electrical connections, checking.....	64	Power generated on site.....	75
– Electrical values.....	102, 106	Power-OFF.....	32, 53
– Floorstanding installation with support.....	20, 21, 22	– With on-site load disconnection.....	55
– Installation.....	13	– Without on-site load disconnection.....	55
– Installing on foundations.....	23	Power-OFF signal.....	56, 58
– Internal components.....	80	Power supply	
– Power supply.....	53, 54	– Compressor.....	25
– Wall mounting.....	23	– General information.....	50
– Wall mounting with bracket.....	24	– Heat pump control unit.....	51, 55, 56
– Weight.....	14, 103, 107	– Instantaneous heating water heater.....	51
Outdoor unit floorstanding installation.....	20, 21, 22	– Outdoor unit.....	53, 54
Outdoor unit installation location.....	15	Premium tariff meter.....	55, 56
Outside temperature sensor.....	44, 83	Pressure, checking.....	62
Overview		Pressure gauge.....	80
– Electrical connections.....	78	Product information.....	8
– Internal components.....	80	Programming unit, opening.....	78
– Pumps.....	80	Protective gloves.....	61
– Sensors.....	80	Pumps.....	37, 80
– Valves.....	80	<b>Q</b>	
Overview of system schemes.....	67	Quick-action air vent valve.....	80
<b>P</b>		<b>R</b>	
Parameter group selection.....	67	RCD.....	55, 56
Parameters		Recommended power cables.....	32
– Cooling function.....	70	Refrigerant circuit.....	103, 106
– DHW circulation pump.....	68	– Tightness test.....	61
– Electric booster heater.....	71	Remote control.....	45, 68
– Energy meters.....	75	Repair work.....	61
– External extension.....	68	Reports.....	89
– External functions.....	69	Reports, compiling.....	61
– External heat generator.....	72	Requirements for the installation location	
– For on-site components.....	67	– Outdoor unit.....	15
– Heating circuit pump.....	68	Reset button.....	77
– Heat pump cascade.....	76	Residual current device.....	50
– Immersion heater.....	72	Return, DHW cylinder.....	104, 107
– Instantaneous heating water heater.....	71	Return, DHW cylinder/heating water.....	30
– Mixer extension kit.....	68	Return, outdoor unit.....	10, 30
– Photovoltaics.....	75	Return temperature sensor, secondary circuit.....	80, 83
– Power generated on site.....	75	Ripple control receiver.....	55, 56
– Remote control.....	68	Room height.....	28
– Report.....	89	Room temperature sensor.....	45, 83
– Smart Grid.....	75	Routing cables.....	33, 47
– Solar DHW heating.....	71	<b>S</b>	
– Swimming pool water heating.....	73	Safety connections.....	43
– Ventilation.....	73, 74	Safety goggles.....	61
Parameter setting.....	67	Safety LV.....	40



## Keyword index (cont.)

Safety valve.....	30, 80
Seal rings, replacing.....	30, 62
Secondary circuit	
– Connection.....	30
– Filling and venting.....	62
Secondary pump.....	80
Self-consumption.....	57
Sensor curves.....	83
Sensor PCB.....	44
Sensors.....	80, 83
Service menu	
– Activating.....	66
– Calling up.....	67
– Deactivating.....	66
Service position.....	79
Service termination.....	66
Side cover, outdoor unit.....	59
Signal connections.....	43
Siting.....	13, 14
– Between walls.....	15
– Conditions.....	13
– Freestanding.....	13
– Indoor unit.....	28
– In recesses.....	15
Smart Grid.....	75
– Connection to EA1 extension.....	58
– Connection to heat pump control unit.....	58
Solar DHW heating.....	71
Sound power.....	104, 107
Sound propagation.....	15
Sound reflections.....	15
Specification.....	101
Starting appliance.....	65
Start sequence, appliance.....	65
Support for floorstanding installation.....	13, 20, 21, 23
Swimming pool.....	45
Swimming pool water heating.....	73
Switching contact.....	31, 40
Switching current.....	40
System overview.....	76
System pressure, checking.....	62
System scheme.....	67
System user instruction.....	77
<b>T</b>	
Temperature limiter.....	38
Temperature sensor.....	44, 83
– Air intake, evaporator.....	81, 82
– Hot gas.....	81, 83
– Suction gas.....	81, 83
Terminator, Modbus.....	45
Tightness test.....	30, 62
– Refrigerant circuit.....	61
Tilting angle.....	13
TNC system.....	55, 56
Top-up water.....	62
Total weight.....	103, 107
Transport.....	13
– Indoor unit.....	27
Type overview.....	9
<b>U</b>	
Underfloor heating.....	38
Underfloor heating circuit.....	38
Use.....	7
Utilisation of power generated on site.....	51
<b>V</b>	
Ventilation.....	73, 74
Venting.....	62
Vibration isolation.....	14
Vitocomfort 200.....	68
<b>W</b>	
Wall mounting.....	24
– Bracket set.....	23
– Indoor unit.....	28
– Outdoor unit.....	23
Warranty.....	65
Water quality.....	62
Weather influences.....	14
Weatherproofing.....	14
Weight.....	14
Wind direction.....	14
Wind loads.....	14

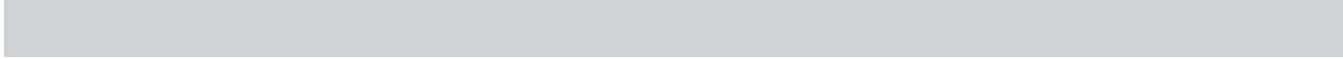



Viessmann Climate Solutions SE  
35108 Allendorf / Germany  
Telephone: +49 6452 70-0  
Fax: +49 6452 70-2780  
[www.viessmann.com](http://www.viessmann.com)



Viessmann Limited  
Hortonwood 30, Telford  
Shropshire, TF1 7YP, GB  
Telephone: +44 1952 675000  
Fax: +44 1952 675040  
E-mail: [info-uk@viessmann.com](mailto:info-uk@viessmann.com)

6150148 Subject to technical modifications.