

HITACHI

# air to water heat pumps

Yutaki range

Cooling & Heating



# Welcome to Hitachi Cooling & Heating, climate control solutions

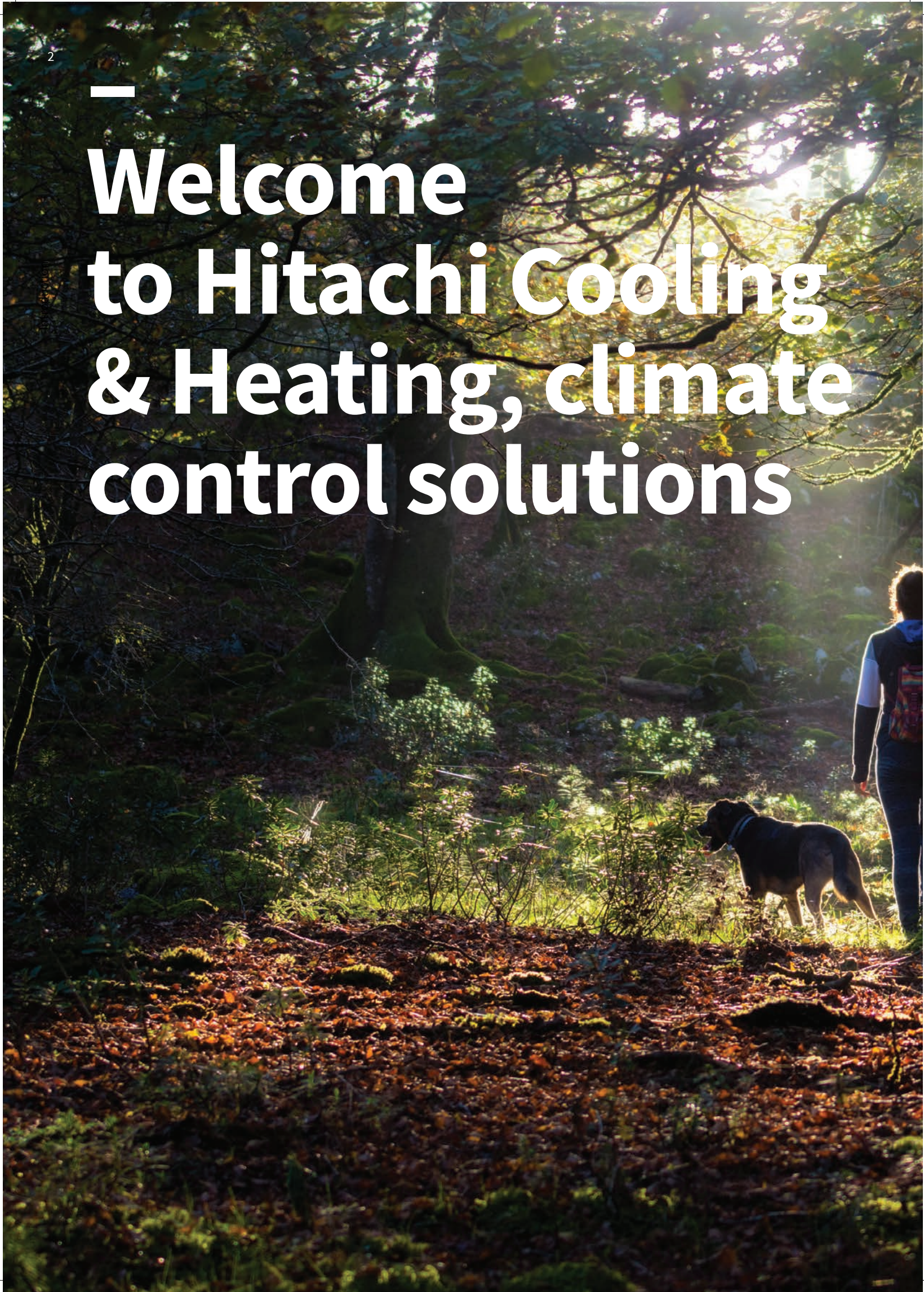

## Time for change

With the ever increasing awareness of climate change, Hitachi has launched a range of renewable heating solutions for homes called Yutaki.

It is clear that our planet is changing and changes need to be made to the way in which we heat our homes.

Hitachi's Yutaki range of air to water heat pumps can provide that alternative.

With the support of Government schemes, changes in the way we build homes and homeowners wanting a better solution to high fossil fuel prices, there is a clearly a need for something different. Something renewable.

With a variety of outputs and water temperatures, the Yutaki range can provide the perfect solution no matter the type of property.

Hitachi has developed simple to install, simple to commission and most importantly **simple to operate** units that are of the highest quality, efficiency and have low noise levels - so we think we have ticked every box!



## CONTENTS

Heating and DHW	7
How does it work?	8
Benefits	10
Yutaki S	18
Yutaki S Combi	22
Yutaki S80	26
Yutaki M	30
Yutaki T	34
Controls and accessories	36
New R32 models	40
Hi-Kumo Pro app	41
Regulations and incentives	42

**EASY TO INSTALL AND  
SIMPLE TO MAINTAIN  
BECAUSE THEY SHARE  
THE SAME COMPONENTS**

**UP TO  
70% ENERGY SAVINGS**  
MORE ENERGY, LESS  
ELECTRICITY

**COMPACT ALL IN ONE  
PRODUCT**

DESIGNED FOR SMALLER  
SURFACE AREAS WITHOUT  
SACRIFICING POWER AND  
EFFICIENCY



ENERGY CLASS A+++\*

\*Depends on model

# Heating and DHW

## Need extra help?



### For further information on compatible controls and accessories

see page 36



### Yutaki Applications Book

Download hydraulic circuit diagrams, detailed information on accessories and junction box connections for the entire Yutaki range.

Using the Yutaki Applications Book, you will optimise the installation process and save time

[www.yutaki-applications.com](http://www.yutaki-applications.com)

### Hi-ToolKit for Home

Specifying, commissioning and installing air source heat pumps can be a challenge but Hitachi's helpful online tools aim to make the process that much easier for installers.

Register for the new Hi-ToolKit for Home software to help with product selection and specification of the most economical domestic heating solution for your customer in just a few clicks - generating a bespoke report that can be personalised with your contact details and logo

[www.hitachi-hitoolkit.com/heating time](http://www.hitachi-hitoolkit.com/heating time)

The Yutaki range has been completely redesigned to achieve greater savings on your fuel bill, as well as easier installation and maintenance.

### Significant savings on power consumption

Even in winter, Yutaki absorbs heat present in the outside air to transform it into energy useful for heating. In Cooling mode, it draws heat from the indoor air and expels it outside. That way, significant energy savings are achieved.

### Low carbon footprint

All Hitachi's R32 Yutaki models feature environmentally-friendly, low Global Warming Potential (GWP) R32 refrigerant and benefit from improved operating ranges. Find all our new R32 models on page 40.



### Maximum comfort, maximum technology

It avoids unnecessary consumption as Hitachi DC inverter technology accurately adjusts power to your heating requirements at any given time.

### Single control

and common commissioning set-up for all ranges. Yutaki can handle up to three remote controls per installation.

### Set your home temperature wherever you are

You only need the Yutaki Hi-Box pack and to download the **Hi-Kumo App** to turn the unit on and off and set the temperature wherever you are using a mobile device.

### Easy and simple to install

Pipes are perfectly aligned at the rear of the unit, which makes for much easier installation compared to other manufacturers.

### Remote maintenance

Remotely consult the operational data of the Yutaki range for online troubleshooting and preventative maintenance.

# How does it work?

The Yutaki heat pump utilises energy in the outside air and transforms it into usable heat. This is performed through a refrigeration process and a vapour compression cycle, which sounds very complicated, but it's basically how a fridge works, but in reverse.



## Heating

The water temperature leaving the heat pump is usually lower than the temperature of a fossil fuel boiler, so radiators will need to be sized correctly or use a low temperature heat emitter such as underfloor heating.

## Domestic Hot Water

A dedicated heat pump hot water cylinder which has a larger coil surface area (which will provide a better heat transfer) will need to be used to complement the Yutaki heat pump. A full range is available through Hitachi such as the Yutaki S Combi which is a pre-plumbed and pre-wired solution.

## The Yutaki range consists of five products:

<b>Yutaki S</b>	(Low temperature - Split)
<b>Yutaki S Combi</b>	(Low temperature - Split Pre-plumbed)
<b>Yutaki S80</b>	(High temperature)
<b>Yutaki M</b>	(Low temperature - Monobloc)
<b>Yutaki T</b>	(Hot water only)

A “**Split**” unit does exactly that. It splits the refrigeration process between the outdoor fan unit and the indoor unit. So, the compressor is in the outdoor unit and two pipes containing refrigerant connects to the indoor unit where the heat exchanger and water side is contained as well as the main controller.

The benefits of a Split unit is that the outdoor unit can be located further away from the property (typically up to 50m) with little or no heat loss. Also the outdoor units tend to be smaller and quieter.

A “**Monobloc**” has the compressor, heat exchanger and water side of the refrigeration cycle all contained in the outdoor unit. Therefore, this requires no special qualifications to install as this is much like a boiler installation.

These five products come in a range of outputs with the smallest capacity at 4.3kW and the largest at 24kW.

Flow temperatures range from 30°C to 80°C.

So, as you can see, the range is extensive and depending on the application, Yutaki will have the answer!



# Heating, domestic hot water (DHW) and cooling with renewable energy

Yutaki S



Yutaki S Combi



Yutaki S80



Yutaki M



Yutaki T



# Benefits

## Yutaki air to water heat pumps

### 1 Your needs change, Yutaki adapts

The day to day needs of your customers will change from heating in winter to cooling in summer and sanitary hot water all year round. They may want to connect solar panels and heat their swimming pools. It's therefore important to have a system able to meet all these needs; able to connect to any style of emitter, new or existing: radiators, underfloor or fan coils.

Able to supply two different zones with different flow temperatures simultaneously such as underfloor downstairs and radiators upstairs.

### 2 Renewable energy, guaranteed savings



Air source heat pumps are considered one of the most energy efficient technologies around, on account that they produce more energy in heat than they consume in electricity.

The Yutaki range has the maximum A+++ energy classification in all its ranges ensuring you make savings on your energy bills, reduce electricity consumption and the impact on the environment.

### 3 Hitachi now offers the widest range of R32 air source heat pumps on the market. The new 4.3 kW R32 monobloc is ideal for new builds

	Min - Max
RAS-2WHVNP	1.85 - 7.0
RAS-2.5WHVNP	1.95 - 9.0
RAS-3WHVNP	2.1 - 11.0
RAS-4WH(V)NPE	4.3 - 15.2
RAS-5WH(V)NPE	4.8 - 16.7
RAS-6WH(V)NPE	5.5 - 17.8
RAS-8WHNPE	9.0 - 25.5
RAS-10WHNPE	10.0 - 32.0

	Nom-Max
RAS-2WHVNP	3.8 - 4.9
RAS-2.5WHVNP	5.0 - 5.8
RAS-3WHVNP	6.0 - 7.0
RAS-4WH(V)NPE	7.2 - 11.8
RAS-5WH(V)NPE	9.5 - 12.6
RAS-6WH(V)NPE	10.5 - 13.7
RAS-8WHNPE	14.0 - 16.4
RAS-10WHNPE	17.5 - 20.6



Heating capacity range under the conditions: water input/output: 30/35 °C; outside temperature: 7/6 °C (WB/DB).

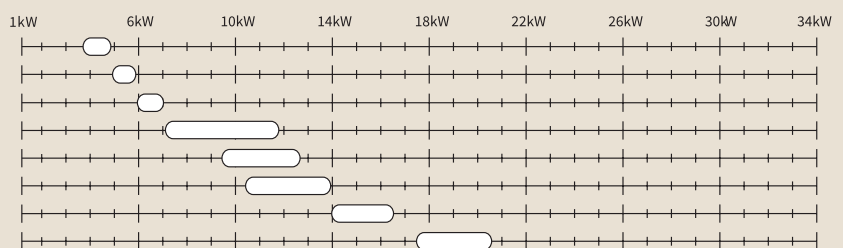

Cooling capacity range under the conditions: water input/output: 23/18 °C; outside temperature: 35 °C (DB).

# 4 Hitachi high-efficiency Scroll Compressor



The Hitachi DC Inverter Scroll compressor has been designed to increase seasonal performance and reliability while reducing energy consumption.

The compressor is particularly efficient in intermediate seasons, offering high performance at low partial charges.

# 5 Proven quality



## SG Ready

Hitachi heat pumps can be integrated into the smart energy grids of the future to help provide the low cost heating systems required to meet carbon reduction targets.



## Proven quality

All heat pumps and water heaters in the European market are continuously tested by various certification schemes. These are usually the basis for qualifying for state subsidies. Hitachi heat pumps meet the high standards of the following quality accreditation schemes: Eurovent, MCS, Keymark, NF PAC, KIWA, EHPA.

# Benefits

## Yutaki air to water heat pumps

### 6 Savings from the very first bill

	Conventional gas boiler	Condensation gas boiler	Diesel boiler	Electricity (radiators)	Heat pump (Yutaki S 6 HP)
Performance (%)	92%	109%	89%	100%	457%
Energy consumption (kWh/year)	21,042.39	17,760.55	21,751.69	19,359.00	4,236.11
Energy cost (£/kWh)	0.0542	0.0542	0.08	0.15	0.15
Energy cost (£/year)	1,140.50	962.62	1,740.13	2,903.85	635.42
Gas emissions (kg CO <sub>2</sub> /kWh)	0.252	0.252	0.311	0.331	0.357
Gas emissions (tonne CO <sub>2</sub> /year)	5.30	4.48	6.76	6.40	1.51
Easy installation	Medium	Medium	High	Low	Medium
Maintenance	Medium	Medium	High	Low	Low
<b>Additional energy costs compared to the heat pump installation</b>	<b>505.08</b>	<b>327.21</b>	<b>1,104.72</b>	<b>2,268.43</b>	<b>—</b>

Estimate based on a 150 m<sup>2</sup> single-family property:  
 Energy demand for heating + hot water (kWh/m<sup>2</sup>): 129.06.  
 Energy demand for heating + hot water (kWh/year): 19,359.

Information sources:  
 - CO<sub>2</sub> emission values taken from the report prepared by the Ministry of Energy, Tourism and Digital Agenda.  
 - Energy prices taken from the Energy Prices Report: Fuels. Data correct at 20th December 2016.



### 7 Hitachi Experience

Hitachi has more than 60 years' experience in manufacturing heating equipment, with over 4.5 million ASHP systems produced and in excess of 400,000 customers throughout Europe. Our European factory produces the entire Yutaki ASHP range, designing it to meet the needs of the local European market. Its nearby location means we can control the whole design and manufacture process, thus guaranteeing the highest levels of quality, reliability and durability in all our equipment.

### 8 Optimised performance with the highest efficiency

The Yutaki range can provide heat with outside temperatures down to -25, uniquely to the market. It can also produce hot water up to 60c without the need for a backup heater.

Yutaki systems are designed to work without backup electrical heaters but some have them factory fitted and for others they are an optional extra. Even when fitted the user can use the simple control systems to disable them.

# 9 Simple installation with easy maintenance

Unlike other models on the market, all Yutaki systems are designed for easy access to the components, thus allowing straightforward maintenance and ensuring cost savings.

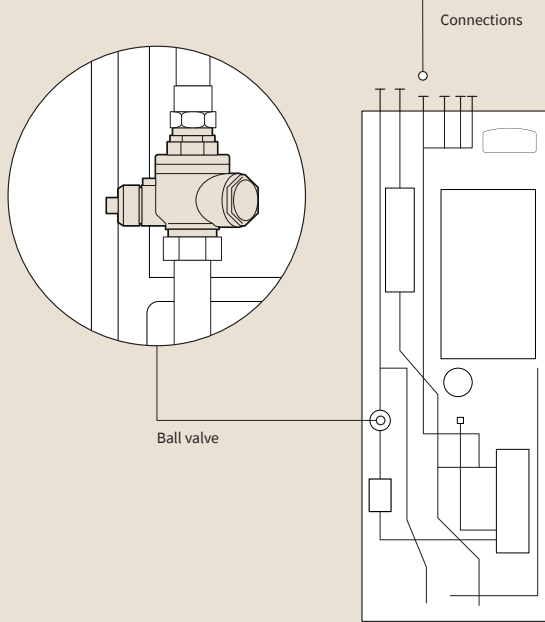
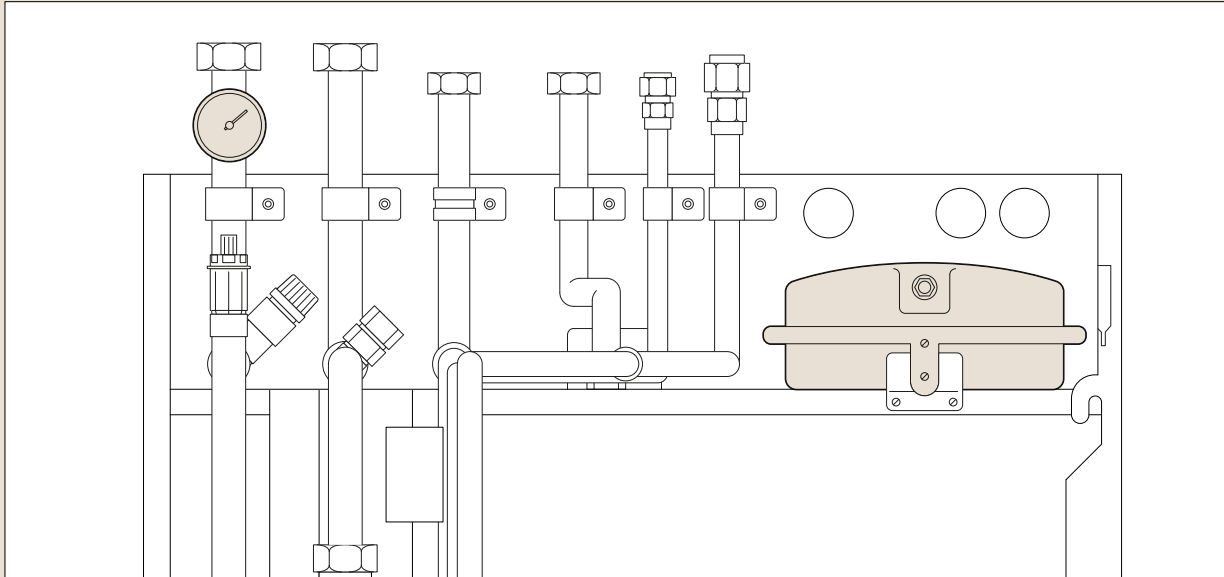

- Filter Plus shut-off valve: Yutaki units are fitted with a ball valve containing an interchangeable cylindrical filter that is easy to inspect and remove for maintenance work. The individual valve has two important functions: to perfectly seal the ball valves and to carefully filter the fluid, with its high-reliability protecting all the components in Hitachi's Yutaki systems.
- Compared to traditional use of three components (one filter and two shut-off valves), the Filter Plus guarantees lower charge losses, in addition to the obvious benefits in terms of cost, installation and space.
- Accessibility: easy access to all components from the front of the machine.
- Pipes: the pipes are perfectly aligned at the back of the unit, making installation much easier compared to other manufacturers.

# 10 Yutaki, configured in under 5 minutes

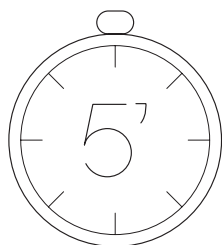

Quick, easy configuration thanks to its intuitive new wizard set-up interface.  
Having the same control throughout the range means any Yutaki can be configured in just 5 minutes.

# Benefits

## Yutaki air to water heat pumps

### 11 Easy, smart control



Hitachi has the same controller and functions for all ranges.

Designed to be user-friendly, handling all system functions: heating, cooling, hot water and swimming pool settings.

The control, with an LCD display and thermostat, centralises all applications without the need for external elements. It can be used for straightforward control of operations such as daily and weekly programming, managing water production temperature, operating modes, etc. It can also be used as a zone thermostat, and even combined with Hitachi's wireless thermostat.

### 12 Yutaki adapts to the needs of modern properties

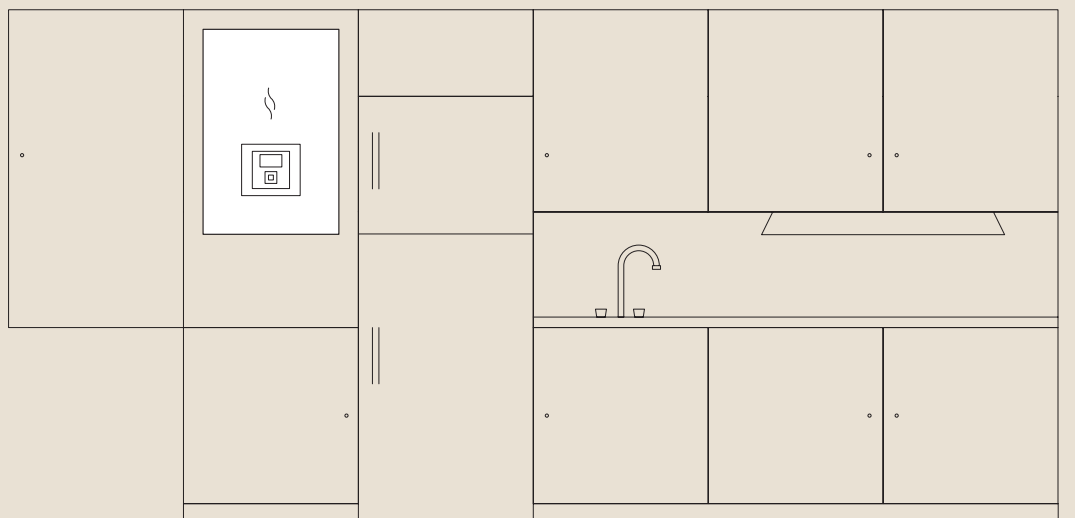

All Yutaki models have been designed to ensure space is not a problem. Their compact size means they can be hidden away in confined spaces, even inside a kitchen cabinet.

Yutaki models are compact and lightweight, designed for smaller surfaces, without sacrificing power and efficiency.

# 13

No matter where you are

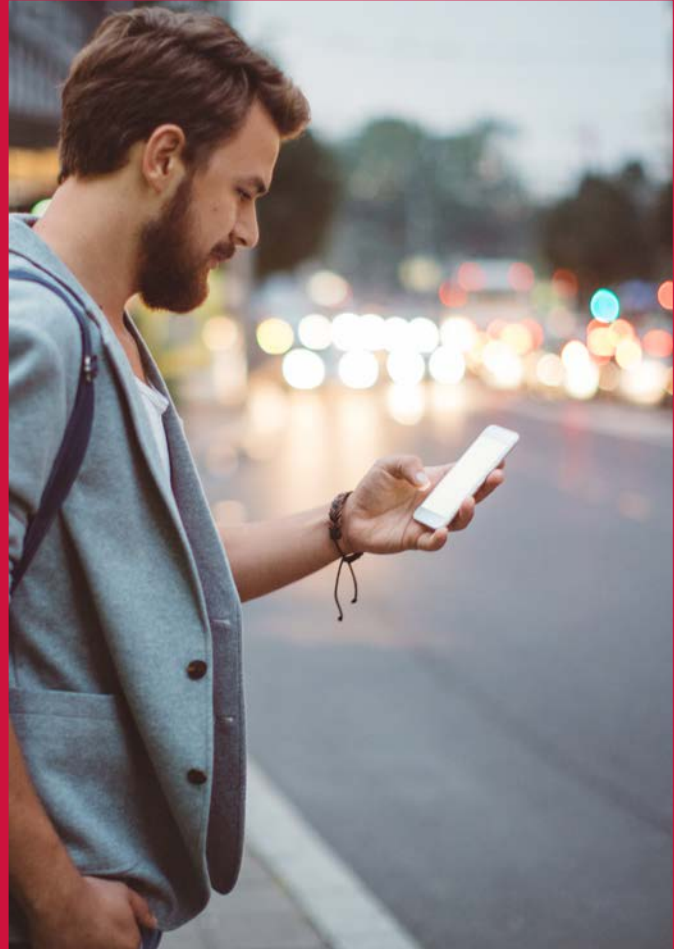

Turn the system on and off and regulate the temperature, or turn on pool heating from anywhere thanks to Yutaki's Hi-Box pack and the free HI-Kumo app.

# 14

Smart defrost cycle

Optimised refrigerant cycle thanks to smart defrost control and a hot gas bypass to the outdoor unit's heat exchanger, making defrosting virtually unnoticeable.

This exclusive improvement reduces time between defrosts, improves energy efficiency, and guarantees machine power at low temperatures, avoiding the need for the backup heating element.

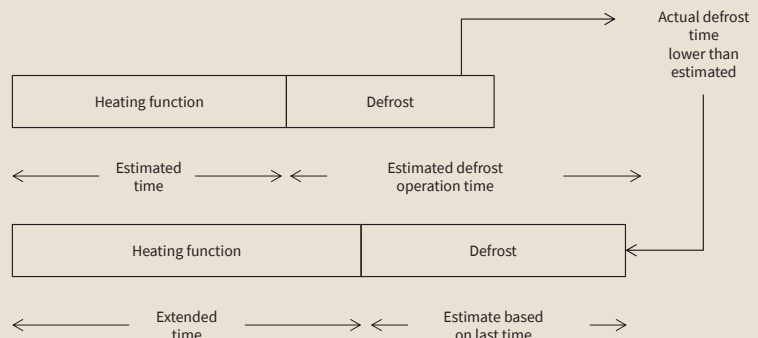

# 15

Additional benefits

Having an expansion valve in the indoor unit allows longer pipe installations while minimising energy losses in the cooling section.

Thanks to the longer pipe length, the Yutaki range can supply greater cooling power to the installation in the summer cycle without affecting the system's electrical consumption.

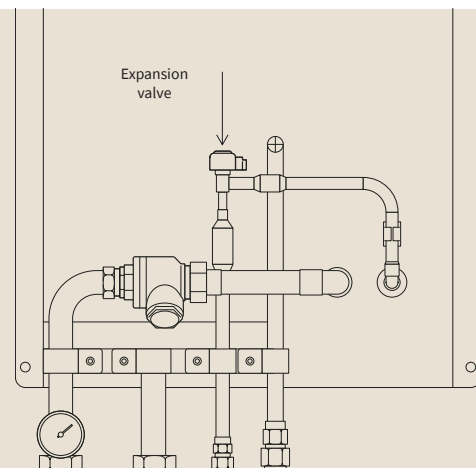

# Resources

## Yutaki air to water heat pumps

### Hi-Toolkit for Home

Yutaki ASHP energy simulation and sizing software

This functional software can be used to quickly and easily select all the systems in Hitachi's Yutaki Air source heat pump range, generating a detailed report with information about the selected machine.

It has a complete database of the main cities in the UK & Ireland and their annual temperatures, in order to carry out an annual energy simulation for the 8,760 hours of the year. Once the simulation is complete, the software compares energy consumption and CO2 emissions with other conventional heating systems in order to evaluate the energy savings that can be achieved when installing Yutaki Air source heat pump equipment.

The website can be found at:  
[www.hitachi-hitoolkit.com/heating](http://www.hitachi-hitoolkit.com/heating)



Monthly consumption of a Yutaki system

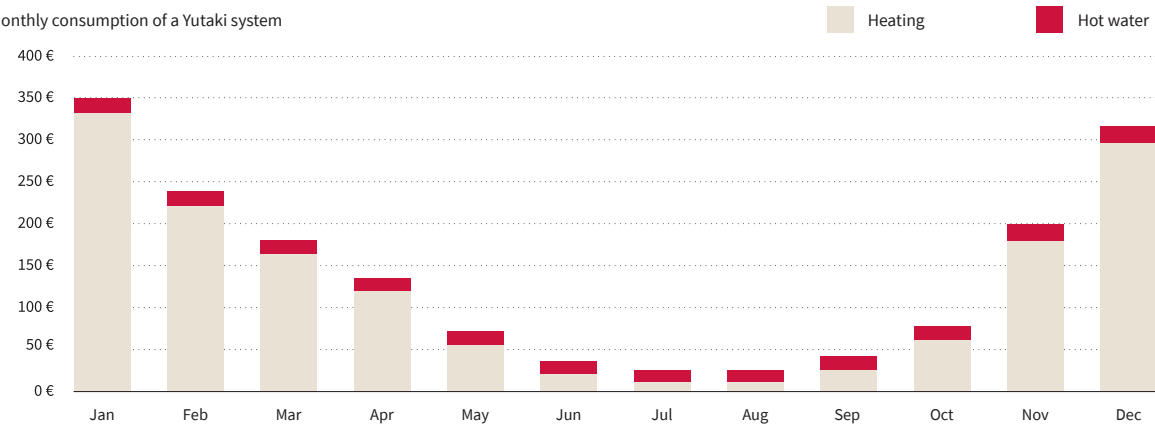

Comparison of Yutaki consumption and other conventional systems

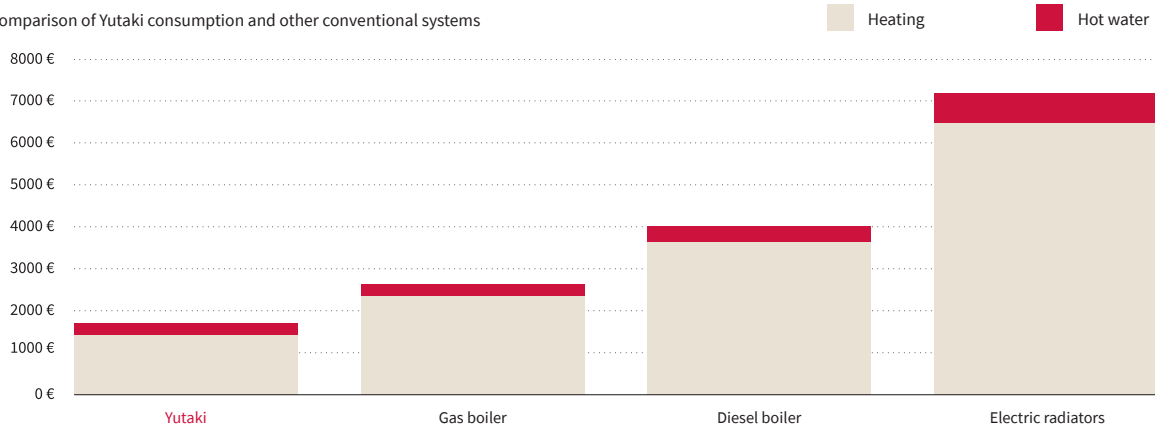



Hitachi has a free online tool for simplified hydraulic configurations of its whole Yutaki ASHP range.

The main elements of the installation can be configured in a few simple steps by simply answering a series of basic questions.

This also makes it easier to install the system, as it indicates directly where each sensor, pump and all other elements on the machine's connections board go.

The website can be found at:  
[www.yutaki-applications.com/en](http://www.yutaki-applications.com/en)

**Hydraulic diagrams**  
 Contact your usual Hitachi direct sales contact or distributor for more detailed hydraulic layouts or any special configurations your installation requires.

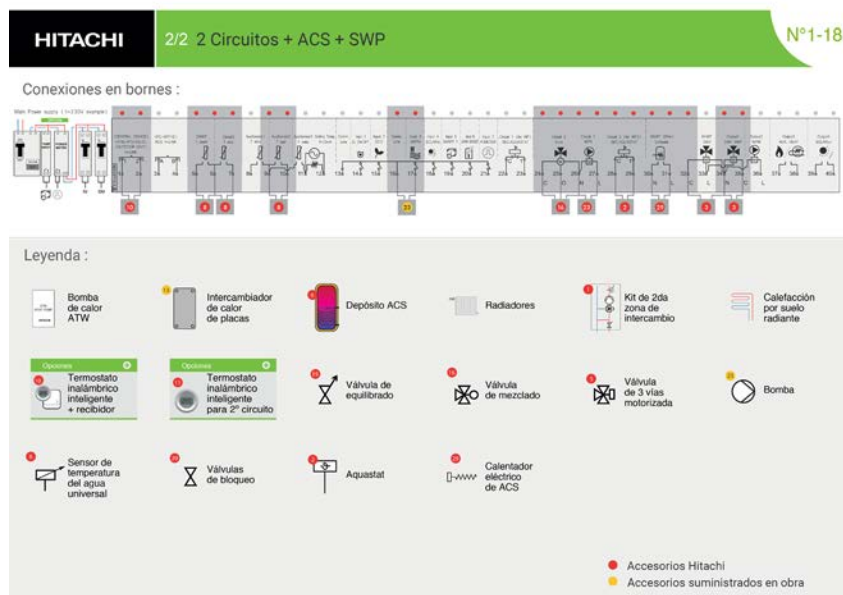
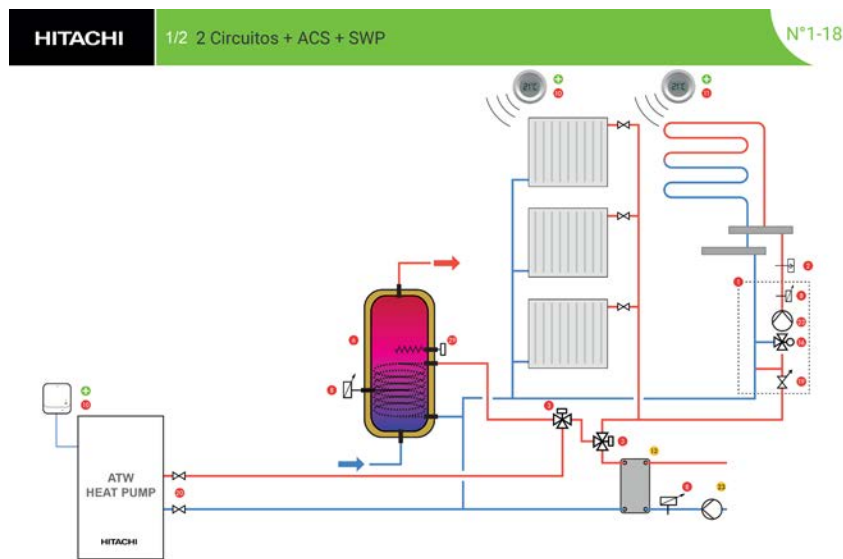

# Yutaki S

Compact, highly efficient system:  
heating, hot water and cooling

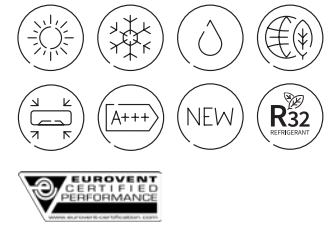

## Satisfies all demands

Extensive range of outputs from 1.85 kW to 32.00 kW for heating, and from 3.80 kW to 20.60 kW for cooling.  
25.50 and 32.00 kW models are unique on the market.

## Compact dimensions

Its compact size and easy installation make it the perfect system for confined spaces. Models from 4.30 to 7.50 kW, even fitting in a kitchen cabinet.  
(Fig. 1)

## Best performance on the market\*

The Yutaki S has the **highest COP** compared to competing systems, which translates into lower energy consumption and bigger savings. All units have up to A+++ maximum energy efficiency.  
\*Depends on model.

## Exclusive design to work in the most extreme conditions

Its broad operating range means the system can work in extreme outdoor conditions: **from -25°C to +46°C.**

## Reduced consumption

Unique on the market - water temperature up to 60 °C without the need for a backup heating element, achieving significant savings compared to other manufacturer models.

Fig. 1

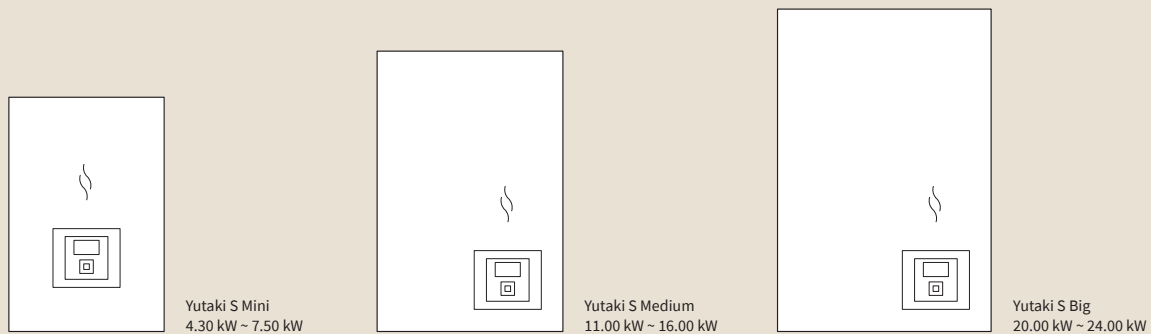

### Indoor units

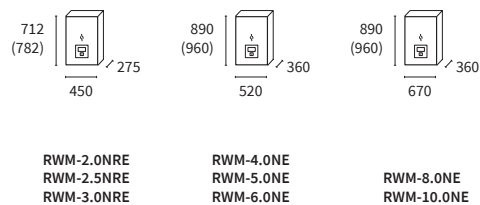

### Outdoor units

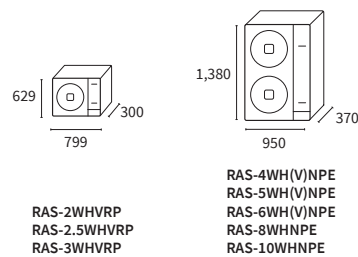

# Yutaki S

System			Yutaki S 2	Yutaki S 2.5	Yutaki S 3	Yutaki S 4	Yutaki S 5	Yutaki S 6	Yutaki S 8	Yutaki S 10
Capacity	Heating (Min/Nom/Max)	kW	1.85/4.30/7.00	1.85/6.00/8.60	2.10/8.00/11.00	4.30/11.00/15.20	4.80/14.00/16.70	5.50/16.00/17.80	9.00/20.00/25.50	10.00/24.00/32.00
	Cooling (Nom/Max)	kW	4.00/5.00	5.30/6.20	6.50/7.00	7.20/11.80	9.50/12.60	10.50/13.70	14.00/16.40	17.50/20.60
Consumption	Heating (Nom)	kW	0.82	1.25	1.74	2.20	2.97	3.50	4.65	5.59
	Cooling (Nom)	kW	1.00	1.47	1.94	2.18	2.68	3.17	4.48	6.22
Electrical power			1 ~230V 50Hz	1 ~230V 50Hz	1 ~230V 50Hz	1 ~230V 50Hz	1 ~230V 50Hz	1 ~230V 50Hz	-	-
			-	-	-	3N ~400V 50 Hz	3N ~400V 50 Hz	3N ~400V 50 Hz	3N ~400V 50 Hz	3N ~400V 50 Hz
COP (Water 35°C, Ambient 7°C)	Nominal		5.25	4.80	4.60	5.00	4.71	4.57	4.30	4.29
EER (Water 7°C, Ambient 35°C)	Nominal		4.00	3.60	3.35	3.30	3.30	3.31	3.12	2.81
Energy rating at 35°C			A+++	A+++	A+++	A+++	A+++	A++	A++	A+
Seasonal efficiency at 35°C, SCOP / ηs			4.93/181	4.58/177	4.25/175	4.75/189	4.45/176	3.90/153	3.83/152	3.60/142
Energy rating at 55°C			A++	A++	A++	A++	A++	A++	A+	A+
Seasonal efficiency at 55°C, SCOP / ηs	Medium climate		3.58/133	3.38/130	3.25/125	3.50/137	3.43/134	3.23/126	3.13/122	2.98/118
ESEER			3.36	3.26	3.26	3.33	3.29	2.84	3.56	3.32
SEER / ηs	Single-phase		4.11/162	4.13/162	3.95/155	4.93/194	4.83/190	4.70/185	4.29/169	4.06/159
	Three-phase		-	-	-	5.05/199	4.92/194	4.78/188	-	-
Outdoor operating temperatures	Heating (DB)	°C	-20 to 25	-20 to 25	-20 to 25	-25 to 25	-25 to 25	-25 to 25	-25 to 25	-25 to 25
	Hot water (DB)	°C	-20 to 35	-20 to 35	-20 to 35	-25 to 35	-25 to 35	-25 to 35	-25 to 35	-25 to 35
	Cooling (DB)	°C	10 to 46	10 to 46	10 to 46	10 to 46	10 to 46	10 to 46	10 to 46	10 to 46
Water production temperatures	Heating	°C	20 to 55	20 to 55	20 to 55	20 to 60	20 to 60	20 to 60	20 to 60	20 to 60
	Hot water	°C	30 to 75	30 to 75	30 to 75	30 to 75	30 to 75	30 to 75	30 to 75	30 to 75
	Cooling	°C	5 to 22	5 to 22	5 to 22	5 to 22	5 to 22	5 to 22	5 to 22	5 to 22
Refrigerant pipe diameter	Liquid-gas	inches	1/4-1/2	1/4-1/2	1/4-5/8	3/8-5/8	3/8-5/8	3/8-5/8	3/8-1	1/2-1
Water pipe diameter	Input-output	inches	1-1	1-1	1-1	1-1/4 - 1-1/4	1-1/4 - 1-1/4	1-1/4 - 1-1/4	1-1/4 - 1-1/4	1-1/4 - 1-1/4
<b>Indoor unit</b>			<b>RWM-2.0NRE</b>	<b>RWM-2.5NRE</b>	<b>RWM-3.0NRE</b>	<b>RWM-4.0NE</b>	<b>RWM-5.0NE</b>	<b>RWM-6.0NE</b>	<b>RWM-8.0NE</b>	<b>RWM-10.0NE</b>
Minimum water volume of the installation		l	28	28	28	38	46	55	76	79
Water flow	(Min-Nom-Max)	m3/h	0.50 - 0.77 - 1.90	0.60 - 1.03 - 2.00	0.60 - 1.29 - 2.10	1.00 - 1.89 - 2.90	1.10 - 2.41 - 3.00	1.2 - 2.75 - 3.00	2.00 - 3.44 - 4.50	2.20 - 4.13 - 4.60
Emergency heating element in primary	Steps/Capacity	n°/kW	3 / 1 - 1 - 1	3 / 1 - 1 - 1	3 / 1 - 1 - 1	3 / 2 - 2 - 2	3 / 2 - 2 - 2	3 / 2 - 2 - 2	3 / 3 - 3 - 3	3 / 3 - 3 - 3
Sound power		dB(A)	37	37	37	39	39	39	47	47
Dimensions (H (with connections) x W x D)		mm	712(782) x450x275	712(782) x450x275	712(782) x450x275	890(960) x520x360	890(960) x520x360	890(960) x520x360	890(960) x670x360	890(960) x670x360
Weight		kg	35	36	37	46	48	48	60	62
Maximum current	Single-phase	A	28.9	28.9	28.9	43.4	43.4	43.4	-	-
	Three-phase	A	-	-	-	24.2	24.2	24.2	29.2	29.2
<b>Outdoor unit</b>			<b>RAS-2WHVRP</b>	<b>RAS-2.5WHVRP</b>	<b>RAS-3WHVRP</b>	<b>RAS-4WH(V)NPE</b>	<b>RAS-5WH(V)NPE</b>	<b>RAS-6WH(V)NPE</b>	<b>RAS-8WHNPE</b>	<b>RAS-10WHNPE</b>
Air flow		m3/h	2,526	2,526	2,982	4,800	5,400	6,000	7,620	8,040
Sound pressure		dB(A)	46	47	50	49	50	50	59	60
Sound power		dB(A)	61	63	64	64	65	67	73	74
Minimum pipe length		m	3	3	3	5	5	5	5	5
Maximum pipe length		m	50	50	50	75	75	75	70	70
Maximum height difference (highest OU/lowest OU)		m	30/20	30/20	30/20	30/20	30/20	30/20	30/20	30/20
Compressor			Scroll DC Inverter	Scroll DC Inverter	Rotary DC Inverter	Scroll DC Inverter	Scroll DC Inverter	Scroll DC Inverter	Scroll DC Inverter	Scroll DC Inverter
Refrigerant			R32	R32	R32	R410A	R410A	R410A	R410A	R410A
Refrigerant charge (length without additional charge)		kg (m)	1.2 (10)	1.3 (10)	1.3 (10)	3.3 (15)	3.4 (15)	3.4 (15)	5.0 (15)	5.3 (15)
Additional refrigerant charge		g/m	15	15	15	60	60	60	65	65
Dimensions (H x W x D)		mm	629x799x300	629x799x300	629x799x300	1,380x950x370	1,380x950x370	1,380x950x370	1,380x950x370	1,380x950x370
Weight		kg	45	45	44	103	103	103	137	139
Maximum current	Single-phase		13	13	17	30	30	30	-	-
	Three-phase		-	-	-	14	14	16	24	24

## Compatible controls and accessories:



**Remote control**  
PC-ARFHE



**3-way valve**  
ATW-3WV-01

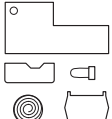

**Cooling Kit**  
Can be used to switch machine operation to cold.  
ATW-CKS-01  
ATW-CKS-02  
ATW-CKS-03

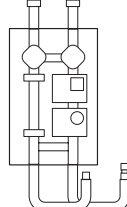

**2nd temperature kit**  
For wall-mounting  
ATW-2TK-07

# Internal design

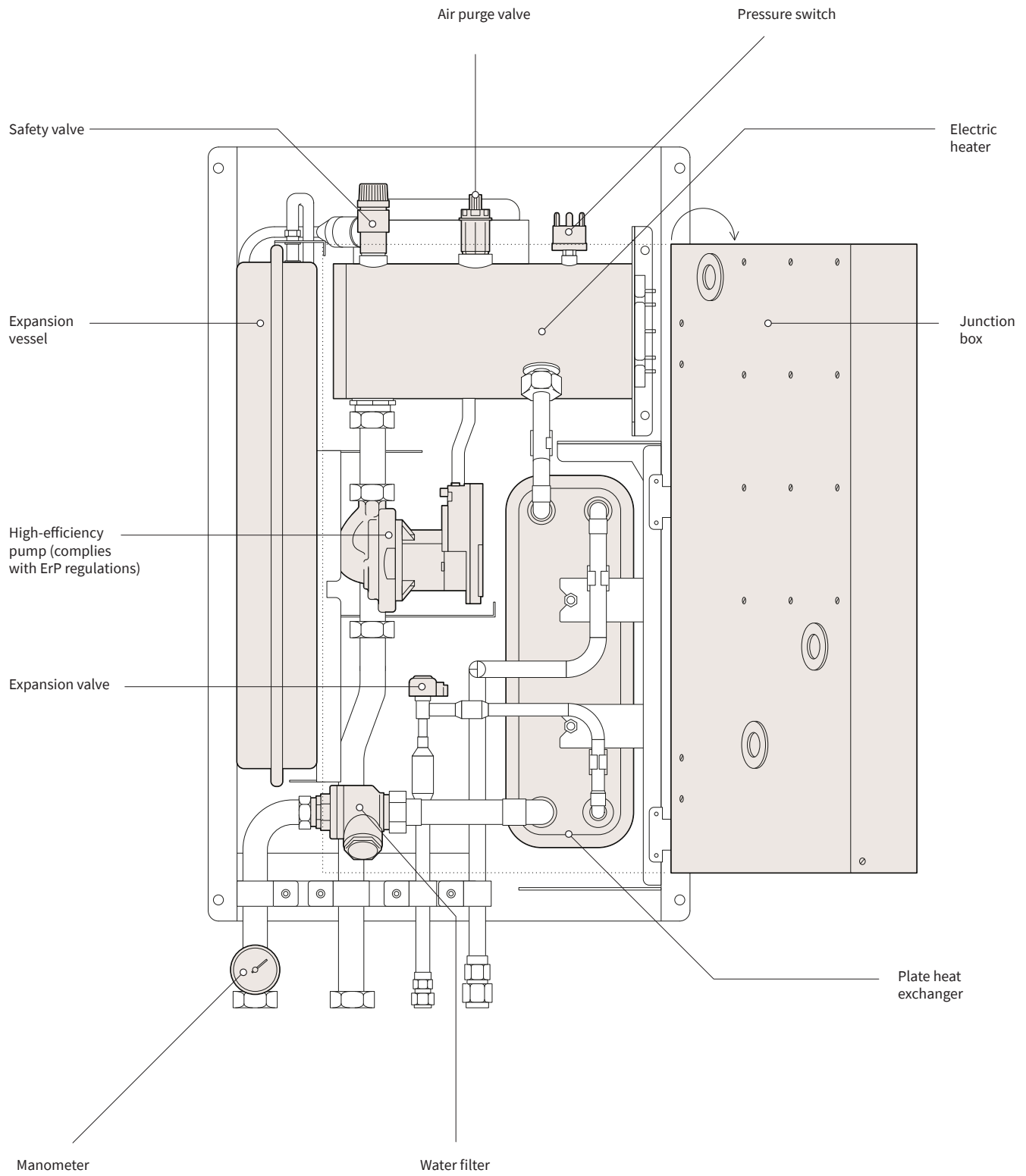

# Configurations

Radiator and underfloor heating at the same temperature; one zone + hot water by external tank.

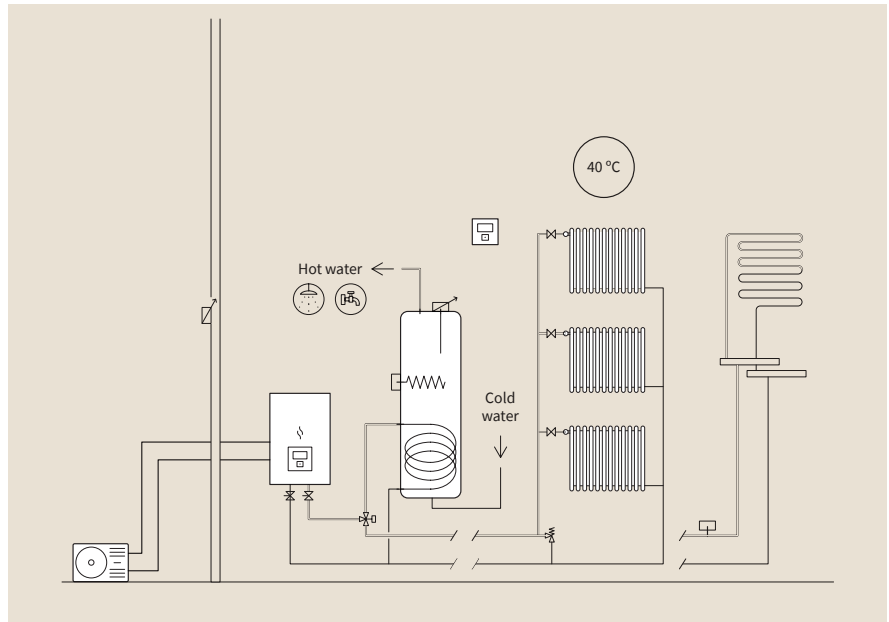

Radiator and underfloor heating at different temperatures; two zones + hot water by external tank.

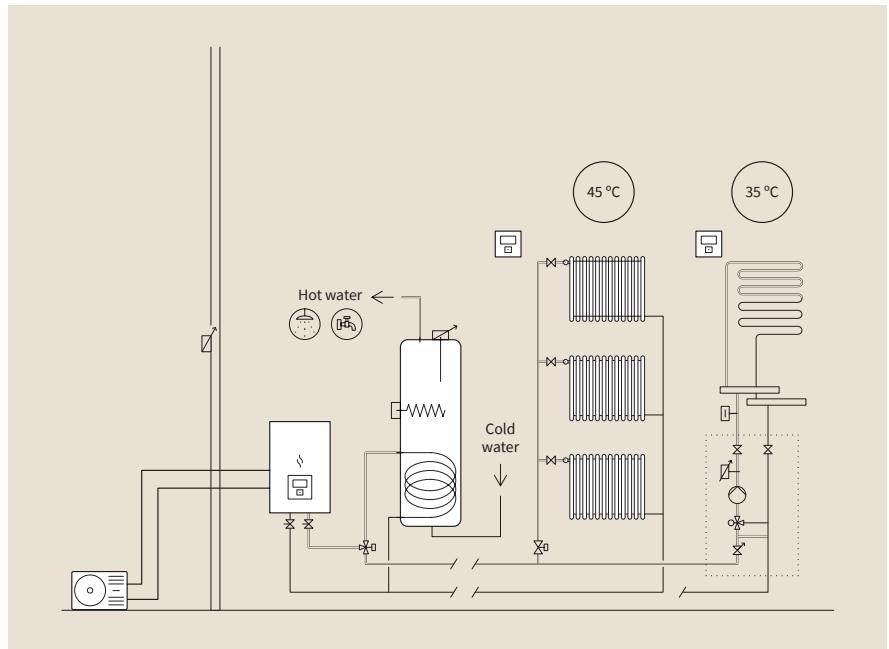

Cascade operation. Heating or cooling.

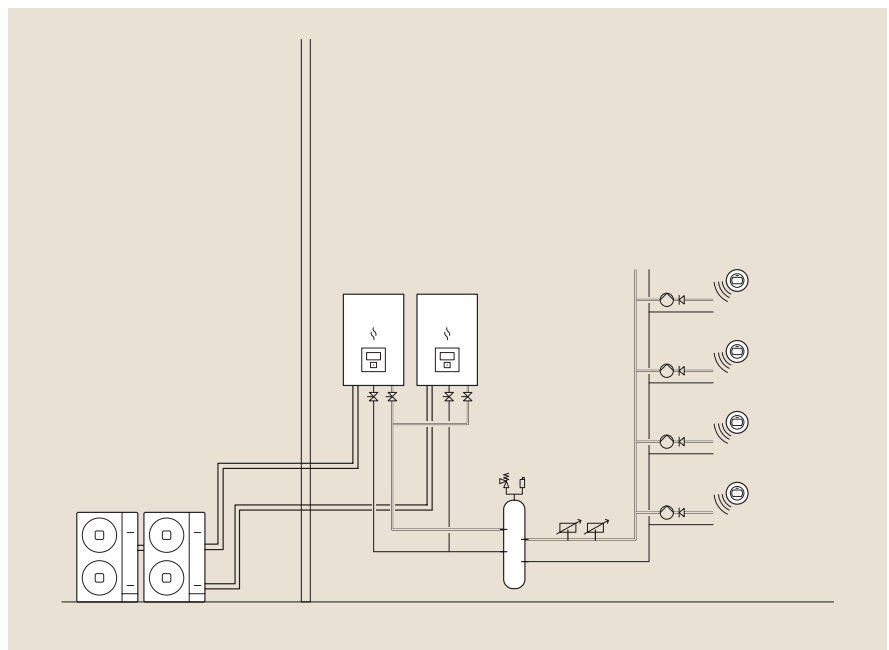

# Yutaki S Combi

Compact all-in-one system: heating, hot water and cooling with integrated stainless steel tank

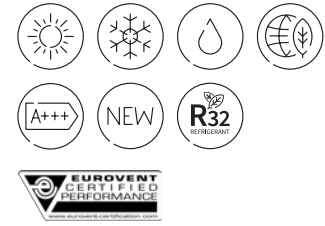

## Extensive range of models

The Yutaki S Combi is designed for any type of installation thanks to its wide range of models. From 1.85 kW to 17.80 kW for heating, and from 3.80 kW to 13.70 kW for cooling.

## Space-saving and ultraquiet

The Yutaki S Combi unit can be installed in the kitchen thanks to its compact size and low noise level.

The large space saving of up to 70 % compared to other system is due to the innovative hot water tank integrated into the indoor unit.

## Choose your size

The Yutaki S Combi includes 2 tank models: 200 and 260 L

Moreover, the 2nd temperature kit can be incorporated into the 200 L unit.

## Easy installation and maintenance

Compared to a split system (indoor unit-hot water tank), the Yutaki S Combi allows fast installation with minimal costs since:

- All water and refrigerant connections are aligned at the top. (Fig. 1)
- Most components are accessible from the front of the unit.
- Easy access to information from the LCD control without having to open the indoor unit.

## Stainless steel tank with built-in heating element

The only compact model fitted with a hot water tank with backup heating element for emergency hot water, activated with a single button.

Fig. 1

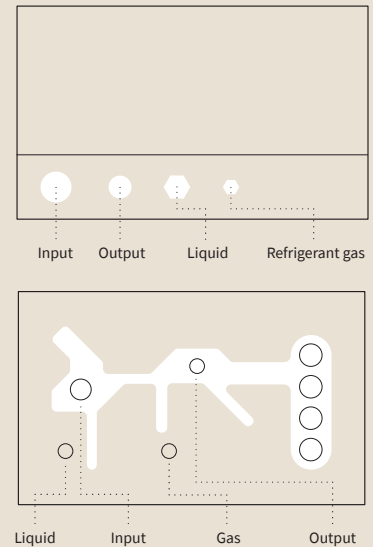

### Indoor units

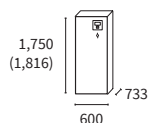

RWD-2.0NRW(S)E RWD-4.0NW(S)E  
RWD-2.5NRW(S)E RWD-5.0NW(S)E  
RWD-3.0NRW(S)E RWD-6.0NW(S)E

### Outdoor units

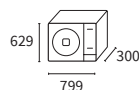

RAS-2WHVRP  
RAS-2.5WHVRP  
RAS-3WHVRP

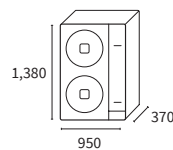

RAS-4WH(V)NPE  
RAS-5WH(V)NPE  
RAS-6WH(V)NPE

## Yutaki S Combi

System			Yutaki S 2 Combi	Yutaki S 2.5 Combi	Yutaki S 3 Combi	Yutaki S 4 Combi	Yutaki S 5 Combi	Yutaki S 6 Combi
Capacity	Heating (Min/Nom/Max)	kW	1.85/4.30/6.50	1.85/6.00/8.60	2.10/8.00/11.00	4.30/11.00/15.20	4.80/14.00/16.70	5.50/16.00/17.80
	Cooling (Nom/Max)	kW	4.00/5.00	5.30/6.00	6.50/7.00	7.20/11.80	9.50/12.60	10.50/13.70
Consumption	Heating (Nom)	kW	0.82	1.25	1.65	2.20	2.97	3.50
	Cooling (Nom)	kW	1.00	1.47	1.94	2.18	2.68	3.17
Electrical power			1 ~230V 50Hz	1 ~230V 50Hz	1 ~230V 50Hz	1 ~230V 50Hz	1 ~230V 50Hz	1 ~230V 50Hz
			-	-	-	3N ~400V 50 Hz	3N ~400V 50 Hz	3N ~400V 50 Hz
COP (Water 35°C, Ambient 7°C)	Nominal		5.25	4.80	4.60	5.00	4.71	4.57
EER (Water 7°C, Ambient 35°C)	Nominal		3.12	3.60	3.35	3.54	3.54	3.31
Hot water energy rating (Profile L - 200l)			A+	A+	A+	A+	A+	A+
Seasonal efficiency hot water, COP <sub>dw</sub> / η <sub>s</sub> (Profile L - 200l)			3.30/132	3.30/132	3.30/132	3.25/130	3.25/130	3.25/130
Hot water energy rating (Profile XL - 260l)			A+	A+	A+	A+	A+	A+
Seasonal efficiency hot water, COP <sub>dw</sub> / η <sub>s</sub> (Profile XL - 260l)			3.40/136	3.40/136	3.40/136	3.35/134	3.35/134	3.35/134
Energy rating at 35°C	Medium climate		A+++	A+++	A+++	A+++	A+++	A++
Seasonal efficiency at 35°C, SCOP / η <sub>s</sub>			4.93/181	4.58/177	4.25/175	4.80/189	4.48/176	3.90/153
Energy rating at 55°C			A++	A++	A++	A++	A++	A++
Seasonal efficiency at 55°C, SCOP / η <sub>s</sub>			3.58/133	3.38/130	3.25/125	3.50/137	3.43/134	3.23/126
ESEER			3.36	3.26	3.26	3.33	3.29	2.84
SEER / η <sub>s</sub>	Single-phase		4.11/162	4.13/162	3.95/155	4.93/194	4.83/190	4.70/185
	Three-phase		-	-	-	5.05/199	4.92/194	4.78/188
Outdoor operating temperatures	Heating (DB)	°C	-20 to 25	-20 to 25	-20 to 25	-25 to 25	-25 to 25	-25 to 25
	Hot water (DB)	°C	-20 to 35	-20 to 35	-20 to 35	-25 to 35	-25 to 35	-25 to 35
	Cooling (DB)	°C	10 to 46	10 to 46	10 to 46	10 to 46	10 to 46	10 to 46
Water production temperatures	Heating	°C	20 to 60	20 to 60	20 to 60	20 to 60	20 to 60	20 to 60
	Hot water	°C	30 to 75	30 to 75	30 to 75	30 to 75	30 to 75	30 to 75
	Cooling	°C	5 to 22	5 to 22	5 to 22	5 to 22	5 to 22	5 to 22
Refrigerant pipe diameter	Liquid-gas	inches	1/4-1/2	1/4-1/2	1/4-5/8	3/8-5/8	3/8-5/8	3/8-5/8
Water pipe diameter	Input-output	inches	1-1	1-1	1-1	1-1/4 - 1-1/4	1-1/4 - 1-1/4	1-1/4 - 1-1/4
Hot water pipe diameter	Input-output	inches	3/4-3/4	3/4-3/4	3/4-3/4	3/4-3/4	3/4-3/4	3/4-3/4
<b>Indoor unit</b>			<b>RWD-2.0NRW(S)E</b>	<b>RWD-2.5NRW(S)E</b>	<b>RWD-3.0NRW(S)E</b>	<b>RWD-4.0NW(S)E</b>	<b>RWD-5.0NW(S)E</b>	<b>RWD-6.0NW(S)E</b>
Minimum water volume of the installation		l	28	28	28	38	46	55
Water flow	(Min-Nom-Max)	m <sup>3</sup> /h	0.50 - 0.77 - 1.80	0.60 - 1.03 - 1.90	0.60 - 1.03 - 1.90	1.00 - 1.89 - 2.70	1.10 - 2.41 - 2.80	1.20 - 2.75 - 2.80
Emergency heating element in primary	Steps/Capacity	n°/kW	3 / 1 - 1 - 1	3 / 1 - 1 - 1	3 / 1 - 1 - 1	3 / 2 - 2 - 2	3 / 2 - 2 - 2	3 / 2 - 2 - 2
Hot water emergency heating element	Steps/Capacity	n°/kW	1 / 2.7	1 / 2.7	1 / 2.7	1 / 2.7	1 / 2.7	1 / 2.7
Sound power		dB(A)	37	37	37	39	39	39
Dimensions (H (with connections) x W x D)		mm	1,750(1,816) x600x733	1,750(1,816) x600x733	1,750(1,816) x600x733	1,750(1,816) x600x733	1,750(1,816) x600x733	1,750(1,816) x600x733
Tank weight 200l / 260l / 260l solar		kg	121/131/131	122/132/132	122/132/132	120/130/130	122/132/132	122/132/132
Solar pipe diameter (260l solar tank)	Input-output	inches	1/2-1/2	1/2-1/2	1/2-1/2	1/2-1/2	1/2-1/2	1/2-1/2
Solar exchange surface (260l solar tank)		m <sup>2</sup>	0.37	0.37	0.37	0.37	0.37	0.37
Maximum current	Single-phase	A	27	27	27	41.5	41.5	41.5
	Three-phase	A	-	-	-	22.4	22.4	22.4
<b>Outdoor unit</b>			<b>RAS-2WHVRP</b>	<b>RAS-2.5WHVRP</b>	<b>RAS-3WHVRP</b>	<b>RAS-4WH(V)NPE</b>	<b>RAS-5WH(V)NPE</b>	<b>RAS-6WH(V)NPE</b>
Air flow		m <sup>3</sup> /h	2,526	2,526	2,982	4,800	5,400	6,000
Sound pressure		dB(A)	46	47	50	49	50	50
Sound power		dB(A)	61	63	64	64	65	67
Minimum pipe length		m	3	3	3	5	5	5
Maximum pipe length		m	50	50	50	75	75	75
Maximum height difference (highest OU/lowest OU)		m	30/20	30/20	30/20	30/20	30/20	30/20
Compressor			Scroll DC Inverter	Scroll DC Inverter	Rotary DC Inverter	Scroll DC Inverter	Scroll DC Inverter	Scroll DC Inverter
Refrigerant			R32	R32	R32	R410A	R410A	R410A
Refrigerant charge (length without additional charge)		kg (m)	1.2 (10)	1.3 (10)	1.3 (10)	3.3 (15)	3.4 (15)	3.4 (15)
Additional refrigerant charge		g/m	15	15	15	60	60	60
Dimensions (H x W x D)		mm	629x799x300	629x799x300	629x799x300	1,380x950x370	1,380x950x370	1,380x950x370
Weight		kg	45	45	44	103	103	103
Maximum current	Single-phase/		13/-	13/-	17/-	30/14	30/14	30/16
	Three-phase							

## Compatible controls and accessories:



**Remote control**  
PC-ARFHE  
Included

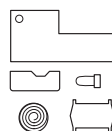

**Cooling Kit**  
ATW-CKSC-01  
Can be used to switch machine operation to cold.

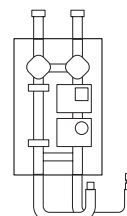

**2nd temperature kit**  
ATW-2TK-06  
Only compatible with built-in Yutaki S Combi 200l.

ATW-2TK-07  
For wall-mounting. Compatible with the entire Yutaki range

# Internal design

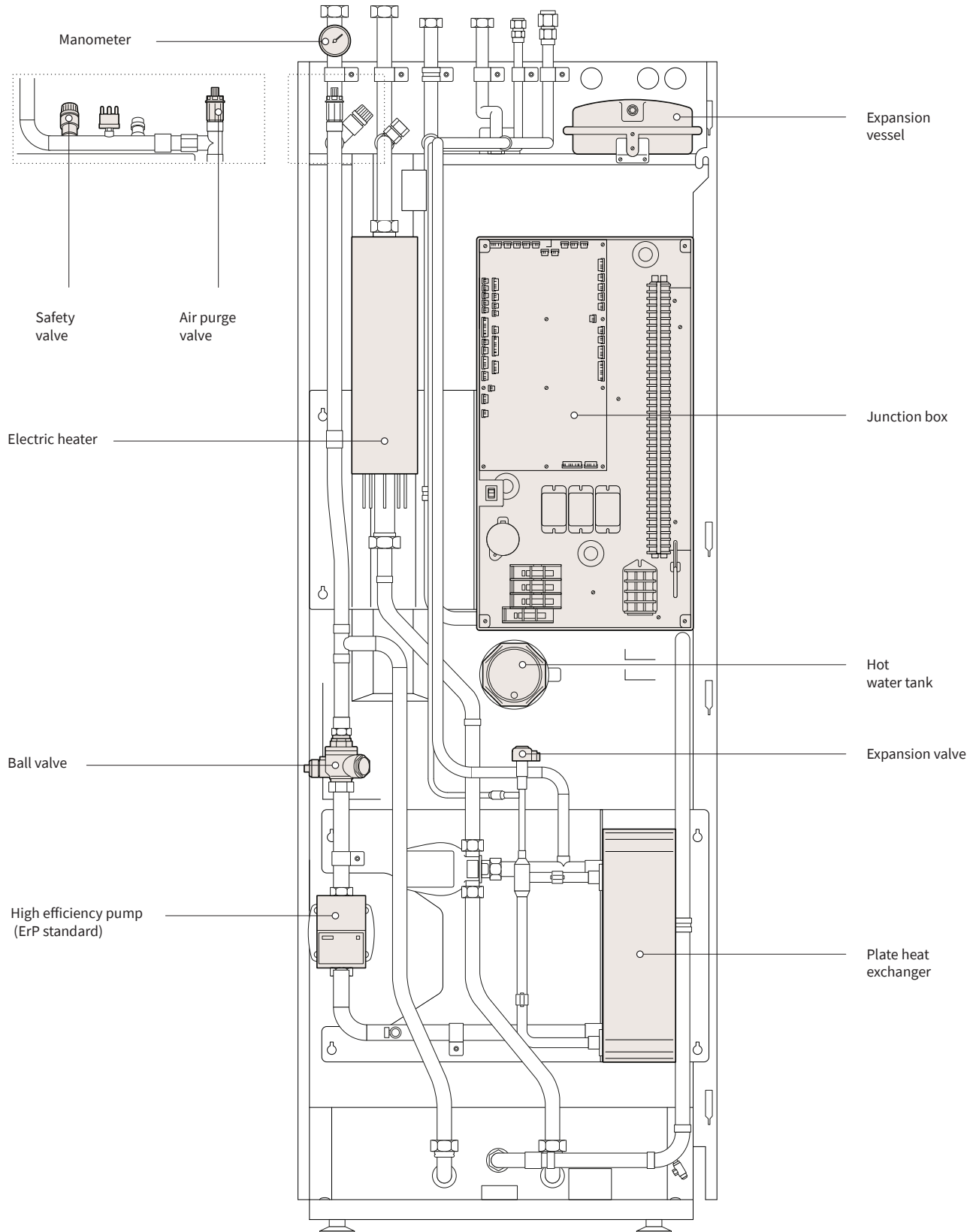



# Configurations

Radiator and underfloor heating at the same temperature; one zone + hot water by built-in tank.

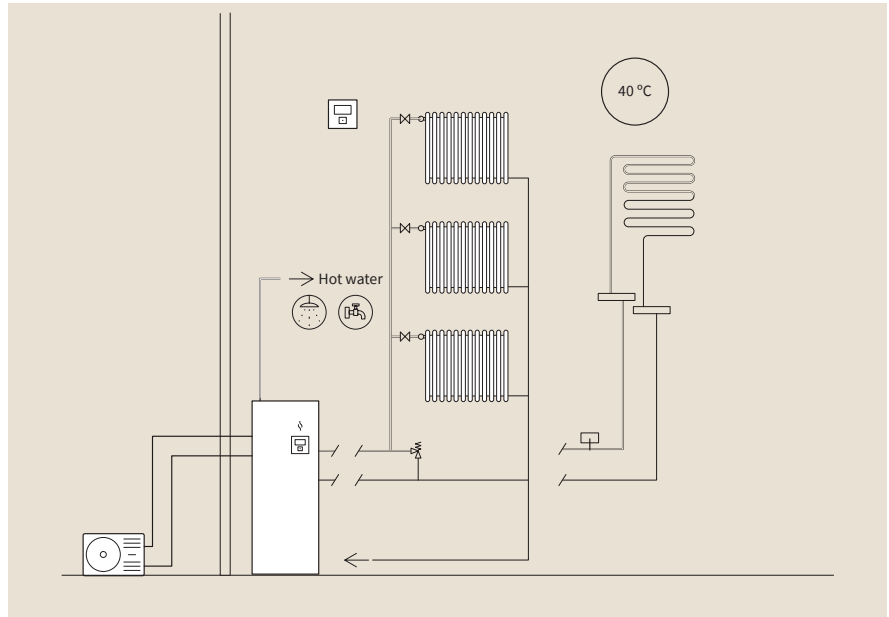

Radiator and underfloor heating at different temperatures; two zones + hot water by built-in tank.

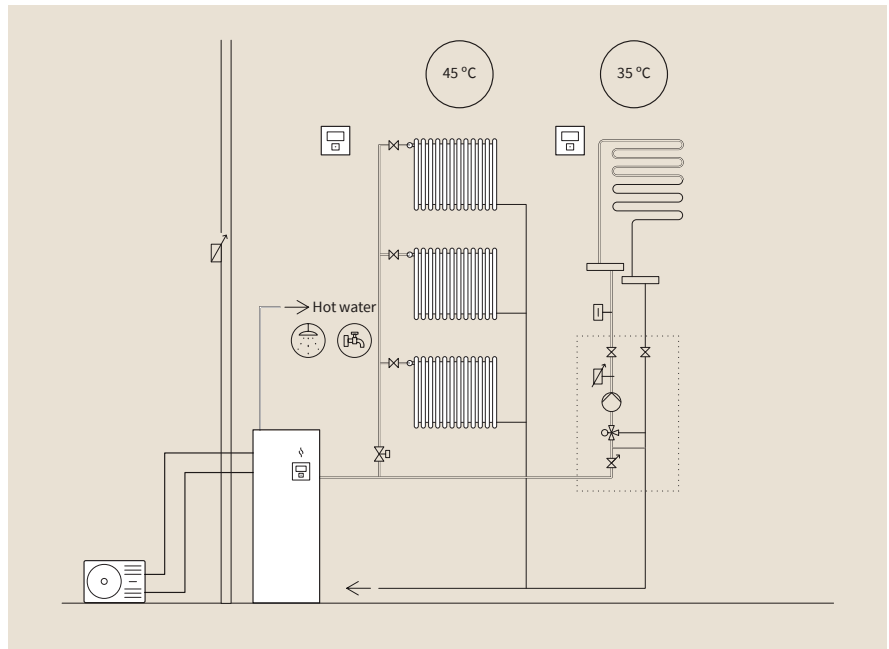

# Yutaki S80

Water temperature up to 80 °C for heating and hot water without an electric heater

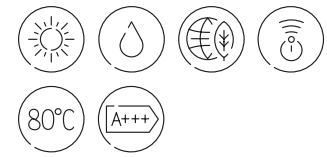

## Maximum efficiency with smart cascade cycle

Yutaki S80 uses two refrigerants: R410A and R134a. Thanks to the unique **Smart Cascade cycle**, the equipment automatically adjusts operation according to heating requirements. When the heating requirement is lower (water temperature up to 53 °C), it only uses the R410A refrigerant; when this requirement increases (water temperature up to 80 °C), it activates the second cycle of R134a refrigerant. Consumption is under control and comfort is guaranteed at all times. (Fig. 1)

## Adapted to each installation

The Yutaki S80 is available in two models, adapting to any needs which may arise: one for heating, and one for heating and hot water. There are two tanks, with 200 and 260-litre capacity, that can be installed as a built-in unit on or next to the indoor unit. (Fig. 2) \*

## Maximum heating capacity

It can heat water **up to 80°C** using renewable energy, even at extreme temperatures down to -25°C.

## Easy installation and maintenance

Its design allows easy access to the water and refrigerant connections, which are fitted in the top of the indoor unit and at the back of the tank unit.

Fig. 1: Smart Cascade cycle configuration

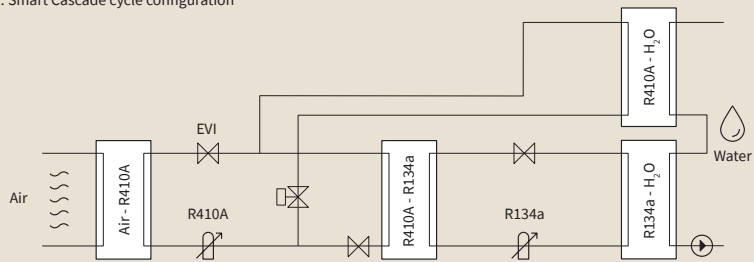
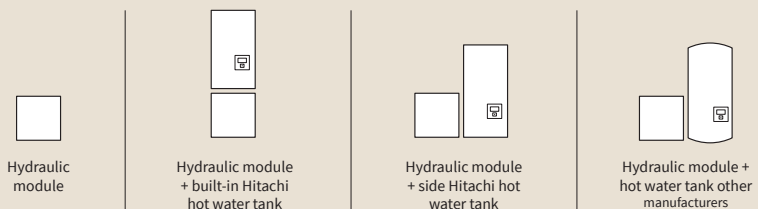
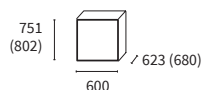

Fig. 2



### Indoor units



RWH-4.0VNFE  
RWH-5.0VNFE  
RWH-6.0VNFE

RWH-4.0VNFWE  
RWH-5.0VNFWE  
RWH-6.0VNFWE

### Outdoor units

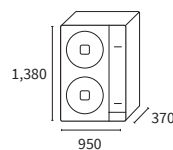

RAS-4WH(V)NPE  
RAS-5WH(V)NPE  
RAS-6WH(V)NPE

\* Two tank options not available in the UK

## Yutaki S80

System			Yutaki S80 4	Yutaki S80 5	Yutaki S80 6
Capacity	Heating (Min/Nom/Max)	kW	4.30/11.00/15.20	4.80/14.00/16.70	5.50/16.00/17.80
Consumption	Heating (Nom)	kW	2.12	2.90	3.43
Electrical power			1 ~230V 50Hz	1 ~230V 50Hz	1 ~230V 50Hz
			3N ~400V 50 Hz	3N ~400V 50 Hz	3N ~400V 50 Hz
COP	Nominal		5.00	4.71	4.57
Energy rating at 35°C			A+++	A++	A++
Seasonal efficiency at 35°C, SCOP / ηs	Medium climate		4.75/187	4.43/174	3.88/152
Energy rating at 55°C			A++	A++	A++
Seasonal efficiency at 55°C, SCOP / ηs			3.63/142	3.35/131	3.23/126
Outdoor operating temperatures	Heating (DB)	°C	-25 to 25	-25 to 25	-25 to 25
	Hot water (DB)	°C	-25 to 35	-25 to 35	-25 to 35
Water production temperatures	Heating	°C	20 to 80	20 to 80	20 to 80
	Hot water	°C	30 to 75	30 to 75	30 to 75
Refrigerant pipe diameter	Liquid-gas	inches	3/8-5/8	3/8-5/8	3/8-5/8
Water pipe diameter	Input-output	inches	1-1/4 - 1-1/4	1-1/4 - 1-1/4	1-1/4 - 1-1/4
Hot water pipe diameter	Input-output	inches	3/4-3/4	3/4-3/4	3/4-3/4
<b>Indoor unit (without tank)</b>			<b>RWH-4.0VNFPE</b>	<b>RWH-5.0VNFPE</b>	<b>RWH-6.0VNFPE</b>
<b>Indoor unit (with hot water tank)</b>			<b>RWH-4.0VNFWE</b>	<b>RWH-5.0VNFWE</b>	<b>RWH-6.0VNFWE</b>
Minimum water volume of the installation		l	40	50	50
Water flow	(Min/Nom/Max)	m3/h	1.00 - 1.26 - 2.80	1.10 - 1.64 - 3.20	1.20 - 1.83 - 3.20
Sound power		dB(A)	57	57	58
Refrigerant			R-134A	R-134A	R-134A
Refrigerant charge		kg	1.90	1.90	1.90
Compressor			Scroll DC Inverter	Scroll DC Inverter	Scroll DC Inverter
Dimensions model S80 (H (with connections) x W x D)		mm	751(802)x600x623	751(802)x600x623	751(802)x600x623
Dimensions model S80 COMBI (H x W x D (with connections))		mm	751x600x623(680)	751x600x623(680)	751x600x623(680)
Model weight without tank	Single-phase	kg	125	129	129
	Three-phase		127	136	136
Model weight with tank	Single-phase	kg	135	139	139
	Three-phase		137	146	146
Maximum current	Single-phase		36	40	43
	Three-phase		22	22	22
<b>Outdoor unit</b>			<b>RAS-4WH(V)NPE</b>	<b>RAS-5WH(V)NPE</b>	<b>RAS-6WH(V)NPE</b>
Air flow		m3/h	4,800	5,400	6,000
Sound pressure		dB(A)	49	50	50
Sound power		dB(A)	61	63	64
Minimum pipe length		m	5	5	5
Maximum pipe length		m	75	75	75
Maximum height difference (highest OU/lowest OU)		m	30/20	30/20	30/20
Compressor			Scroll DC Inverter	Scroll DC Inverter	Scroll DC Inverter
Refrigerant			R410A	R410A	R410A
Refrigerant charge (length without additional charge)		kg (m)	3.3 (15)	3.4 (15)	3.4 (15)
Additional refrigerant charge		g/m	60	60	60
Dimensions (H x W x D)		mm	1,380x950x370	1,380x950x370	1,380x950x370
Weight		kg	103	103	103
Maximum current	Single-phase		20	25	25
	Three-phase		14	14	16

## Compatible controls and accessories:



Remote control  
PC-ARFHE

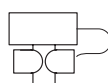

3-way valve  
ATW-3WV-01

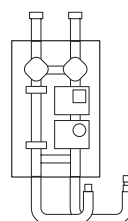

2nd temperature kit  
ATW-2TK-07  
For wall-mounting

## Others:

- Heating element. WEH-6E.
- Water temperature sensor for Cylinders & Buffer tanks ATW-WTS-02Y

# Internal design

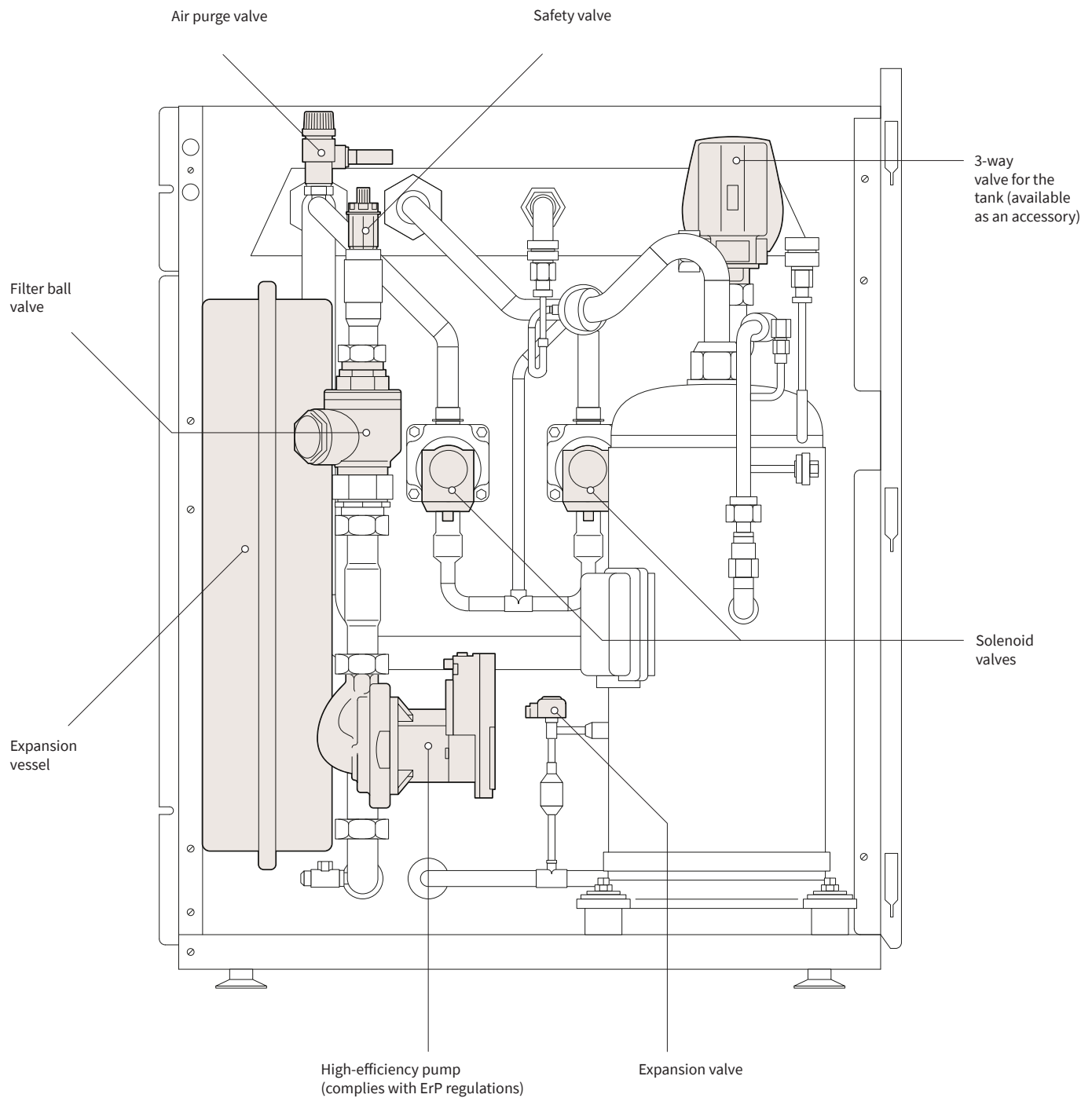

Its flexible design allows different installation possibilities and flexible pipe connection.

- Hydraulic module.
- Hydraulic module + built-in Hitachi hot water tank (not available in the UK).
- Hydraulic module + Hitachi hot water tank on one side (not available in the UK).
- Hydraulic module + third-party hot water tank.

# Configurations

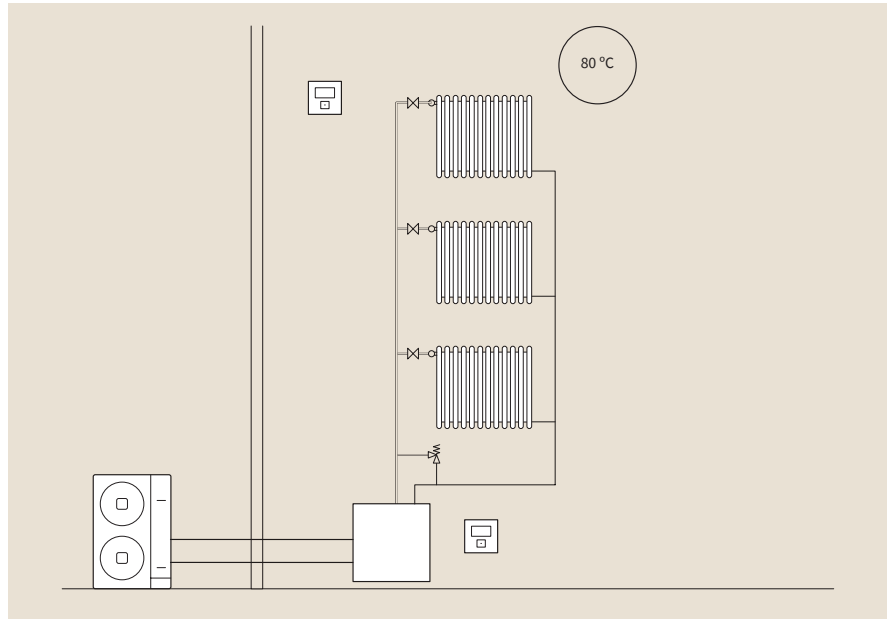

Heating, one circuit.

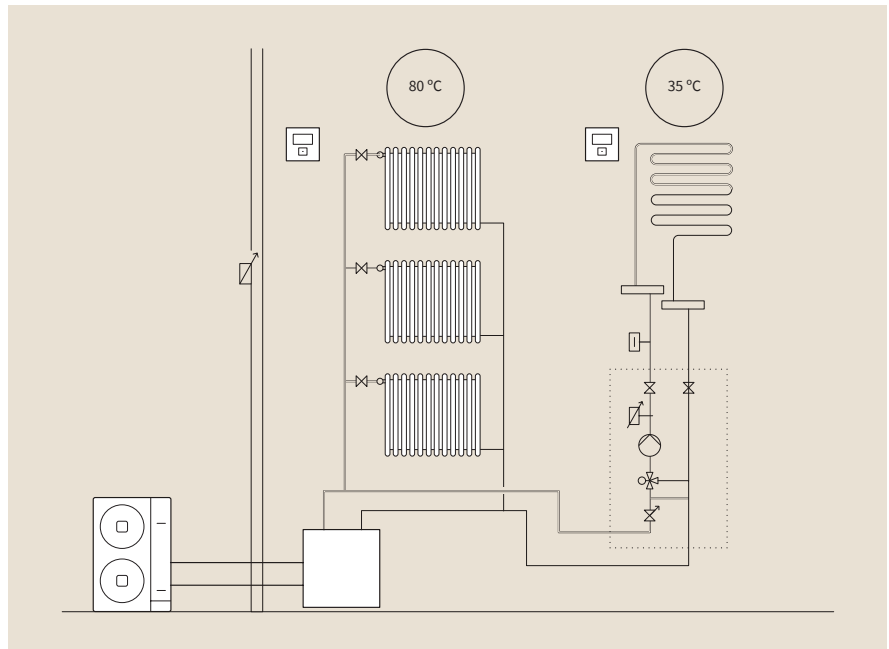

Heating, radiators and underfloor heating at different temperatures; two zones.

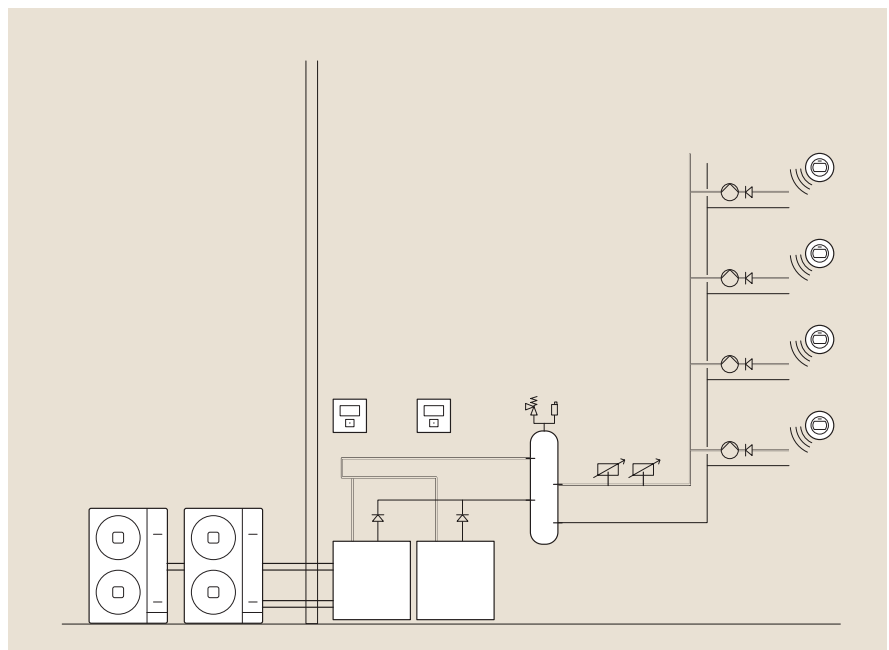

Heating, cascade operation.

# Yutaki M

Compact unit for heating, hot water and cooling without refrigeration connections

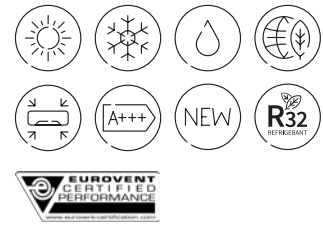

## Perfect for small spaces

The Hitachi monobloc system is designed for installation in any type of property, especially homes with limited space.

Being a compact system with a single unit installed outdoors means the available space indoors remains unchanged.

## Easy to install

The monobloc system ensures all functions are achieved with a single outdoor unit, bringing significant cost savings. Furthermore, installation time is much shorter since practically no pipes are required, there are no cooling connections, and the product is pre-charged at the factory.

## Heating and cooling in a single system all year round

By combining the Yutaki M and the **Cooling Kit**, the accessory used to reverse heat pump operation ensures maximum comfort can be enjoyed all year round. The system therefore offers heating in winter and cooling in summer, all with straightforward installation.

## Easy, smart control

The control with LCD screen can be used for daily and weekly programming, managing water production temperature, operating modes, etc.

(Fig. 1)

Fig. 1



PC-ARFHE control

### Outdoor units

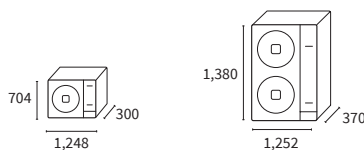

RASM-2VRE  
RASM-3VRE

RASM-4(V)NE  
RASM-5(V)NE  
RASM-6(V)NE

## Yutaki M

Name of the system			Yutaki M 2	Yutaki M 3	Yutaki M 4	Yutaki M 5	Yutaki M 6
Outdoor unit			RASM-2VRE	RASM-3VRE	RASM-4(V)NE	RASM-5(V)NE	RASM-6(V)NE
Capacity	Heating (Min/Nom/Max)	kW	1.85/4.30/6.50	2.1/8.00/11.00	4.30/11.00/15.20	4.80/14.00/16.70	5.50/16.00/17.80
	Cooling (Nom/Max)	kW	4.00/5.00	6.50/7.00	7.20/11.80	9.50/12.60	10.50/13.70
Consumption	Heating (Nom)	kW	0.82	1.74	2.20	2.97	3.50
	Cooling (Nom)	kW	1.00	1.94	2.18	2.68	3.17
Electrical power	Single-phase		1 ~230V 50Hz	1 ~230V 50Hz	1 ~230V 50Hz	1 ~230V 50Hz	1 ~230V 50Hz
	Three-phase		-	-	3N ~400V 50 Hz	3N ~400V 50 Hz	3N ~400V 50 Hz
COP (Water 35°C, Ambient 7°C)	Nominal		5.25	4.60	5.00	4.71	4.57
EER (Water 7°C, Ambient 35°C)	Nominal		4.00	3.35	3.54	3.54	3.31
Energy rating at 35°C			A+++	A+++	A+++	A+++	A++
Seasonal efficiency at 35°C, SCOP / ηs			4.93/181	4.25/177	4.75/187	4.45/175	3.90/153
Energy rating at 55°C			A++	A++	A++	A++	A++
Seasonal efficiency at 55°C, SCOP / ηs	Medium climate		3.58/133	3.25/125	3.48/136	3.40/133	3.30/125
ESEER			3.36	3.26	3.33	3.29	2.84
SEER / ηs	Single-phase		4.11/162	3.95/155	4.93/194	4.83/190	4.70/185
	Three-phase		-	-	5.05/199	4.92/194	4.78/188
Outdoor operating temperatures	Heating (DB)	°C	-20 to 25	-20 to 25	-25 to 25	-25 to 25	-25 to 25
	Hot water (DB)	°C	-20 to 35	-20 to 35	-25 to 35	-25 to 35	-25 to 35
	Cooling (DB)	°C	10 to 46	10 to 46	10 to 46	10 to 46	10 to 46
Water production temperatures	Heating	°C	20 to 60	20 to 60	20 to 60	20 to 60	20 to 60
	Hot water	°C	30 to 75	30 to 75	30 to 75	30 to 75	30 to 75
	Cooling	°C	5 to 22	5 to 22	5 to 22	5 to 22	5 to 22
Maximum current	Single-phase		12.7	17.2	30.8	30.8	30.8
	Three-phase		-	-	14.3	14.3	16.3
Water pipe diameter	Input-output	inches	1-1	1-1	1-1/4 - 1-1/4	1-1/4 - 1-1/4	1-1/4 - 1-1/4
Minimum water volume of the installation		l	28	28	38	46	55
Water flow	(Min/Nom/Max)	m3/h	0.50 - 0.77 - 1.90	0.60 - 1.29 - 2.10	1.00 - 1.89 - 2.80	1.10 - 2.41 - 3.00	1.20 - 2.75 - 3.00
Air flow		m3/h	2,526	2,982	4,800	5,400	6,000
Sound power		dB(A)	61	69	64	65	69
Compressor			Scroll DC Inverter	Rotary DC Inverter	Scroll DC Inverter	Scroll DC Inverter	Scroll DC Inverter
Refrigerant			R32	R32	R410A	R410A	R410A
Refrigerant charge		kg (m)	1.20	1.30	2.80	3.10	3.10
Dimensions (H x W x D)		mm	704 x 1,248 x 300	704 x 1,248 x 300	1,380x1,252x370	1,380x1,252x370	1,380x1,252x370
Weight	Single-phase	kg	76	78	131	133	133
	Three-phase		-	-	130	132	132

## Compatible controls and accessories:



Remote control  
PC-ARFHE

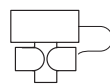

3-way valve  
ATW-3WV-01

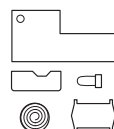

Cooling Kit  
ATW-CKM-01  
Can be used to switch machine operation to cold.

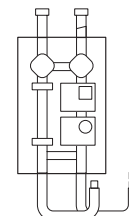

2nd temperature kit  
ATW-2TK-07  
For wall-mounting

# Internal design

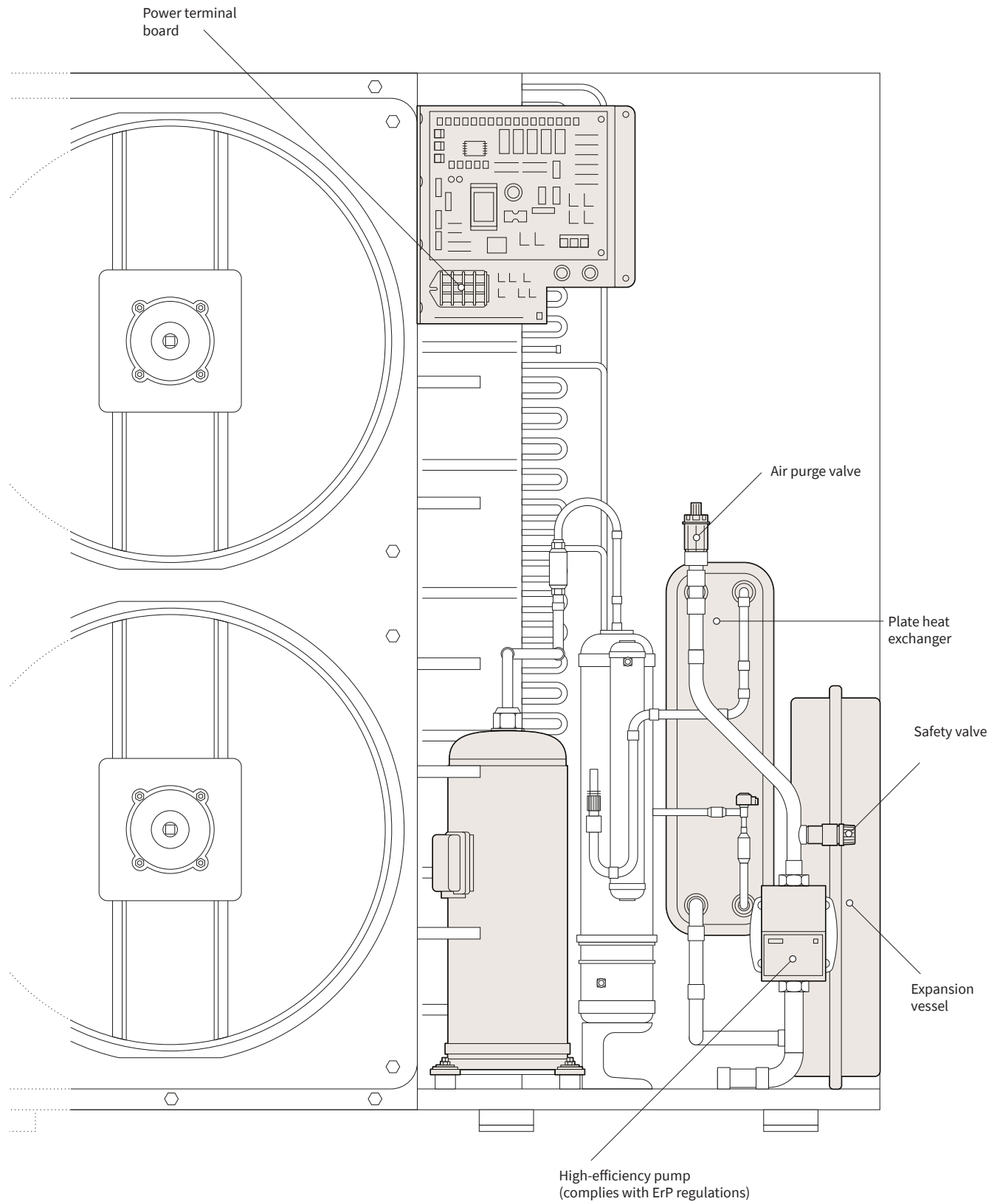



# Configurations

Radiator and underfloor heating at the same temperature; one zone + hot water by external tank.

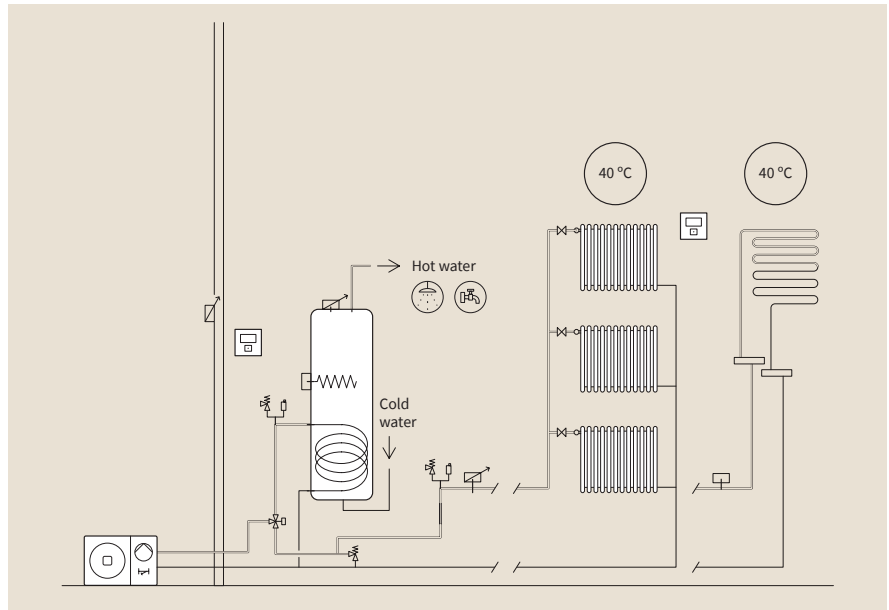

Radiator and underfloor heating at different temperatures; two zones + hot water by external tank.

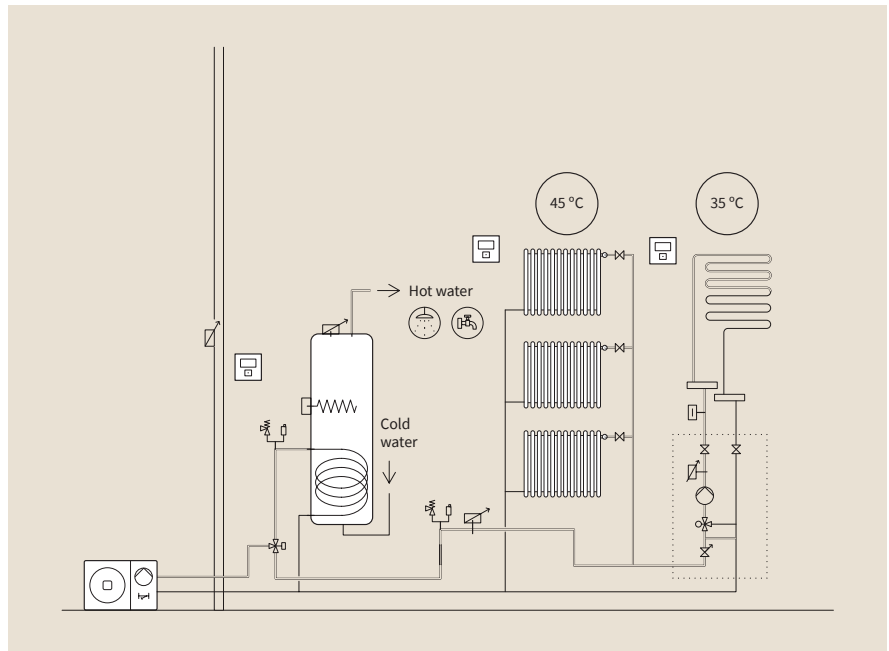



# Yutaki T

The simplest and most economical way to produce hot water



## Maximum comfort, minimum consumption

The unit absorbs heat from the outdoor air, and transfers it to the tank to heat the water up to 55 °C. This achieves **savings of 70%** compared to traditional heaters.

## Greater durability

Yutaki tanks are now coated with duplex stainless steel, a material that offers greater resistance to high temperatures and corrosion.

## More ecological

By using renewable energy to heat the water, it does not emit CO<sub>2</sub>, and allows smart management of operation thanks to the weekly programmable clock.

## Bespoke tank

The Yutaki T range is made up of two models, 190 and 270 litre-capacity, tailored to the needs of each home. The compact 190 litre model can be installed in standard 600 x 600 mm cabinets. It is now also 10 kilos lighter and has a refrigerant coil on the outside, thus increasing the volume of refrigerant.

## Control operation from anywhere

The smart function allows operation to be programmed in advance, bringing significant savings in consumption. It can also be connected to MODBUS for home automation.

## Error identifier

The equipment has a self-diagnostic system, allowing errors to be identified easily thanks to the flashing LED on the indoor and outdoor units.

## Yutaki T configuration

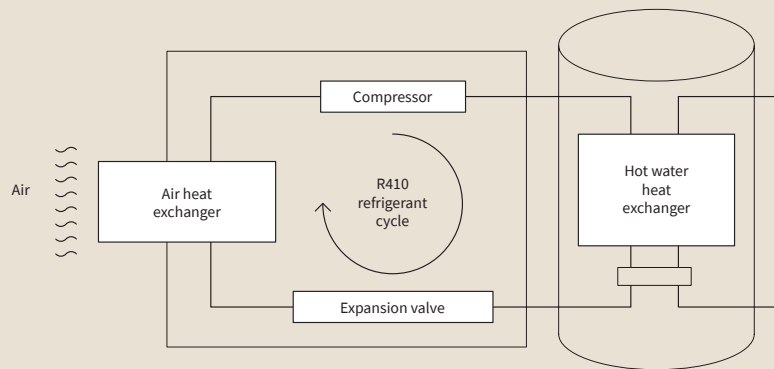

Hot water tank

Outdoor units

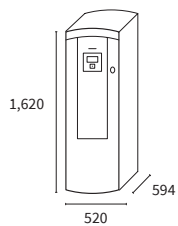

TAW-190NHB  
TAW-270NHB

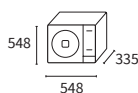

RAW-35NHB

\* Product range is not currently available in the UK.

# Yutaki T

Hot water tank			TAW-190NHB	TAW-270NHB
Capacity		l	190	270
Hot water energy rating			A+	A+
Seasonal efficiency hot water, COP DHW /ηs	Medium climate		3.10/123	3.20/125
Material			Duplex stainless steel	Duplex stainless steel
Declared charge profile			L	XL
Energy consumed in standby mode		kWh	24.90	20.00
Maximum volume of usable water (At 40°C)		l	256	356
Heating time		h:min	3:15	3:35
Maximum water temp. (with heating element)		°C	55 (75)	55 (75)
Electrical power			1 ~230V 50Hz	1 ~230V 50Hz
Electrical power	Liquid-gas	inches	1/4-3/8	1/4-3/8
Hot water pipe diameter	Input-output	inches	3/4-3/4	3/4-3/4
Dimensions (H x W x D)		mm	1,620x520x594	1,620x600x674
Weight		Kg	49	54
Outdoor unit			RAW-35NHB	RAW-35NHB
Air flow		m3/h	1,620	1,620
Sound power		dB(A)	63	63
Minimum pipe length		m	5	5
Maximum pipe length		m	20	20
Maximum height difference-highest OU		m	10	10
Outdoor operating temperatures	Hot water (DB)	°C	-15 to 37	-15 to 37
Compressor			Rotary	Rotary
Refrigerant			R410A	R410A
Refrigerant charge (length without additional charge)		kg (m)	1.2 (20)	1.2 (20)
Additional refrigerant charge		g/m	not required	not required
Dimensions (H x W x D)		mm	548x841x335	548x841x335
Weight		kg	33	33
Electrical power			1 ~230V 50Hz	1 ~230V 50Hz

## Internal design

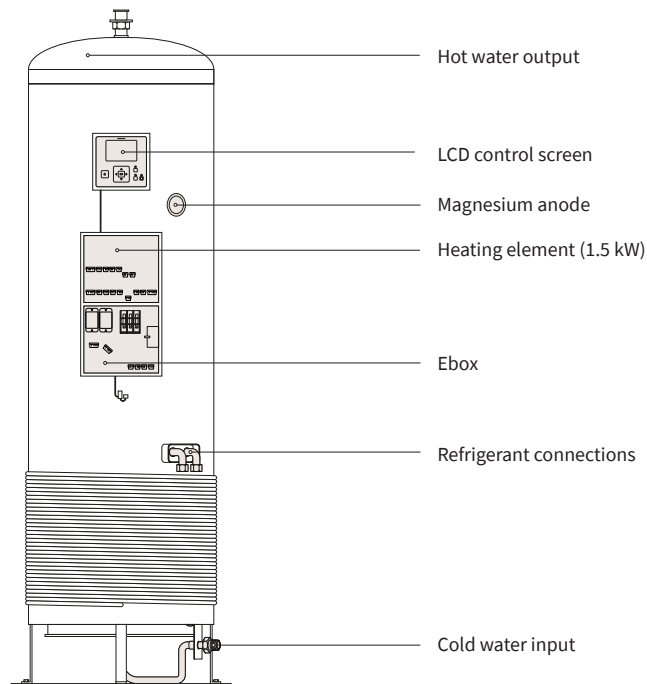

Hot water tank shown is not currently available in the UK

## Compatible controls and accessories:



Hi-Kumo

# Controls



## Wireless thermostat ON/OFF

ATW-RTU-04

- Includes receiver.
- ON/OFF function.
- Easy to install.

Compatibility: Entire Yutaki range.



## Smart wireless thermostat

ATW-RTU-07

- Includes receiver.
- Multifunction.
- Easy to install.

Compatibility: Entire Yutaki range.

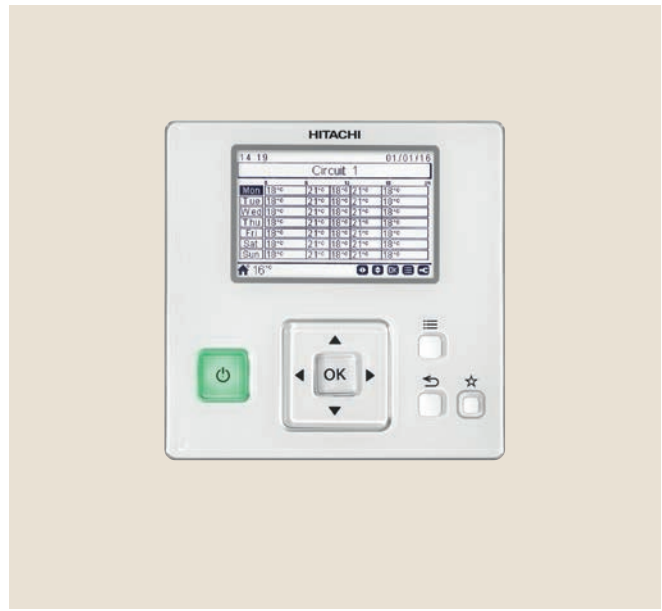

## Wired control

PC-ARFH1E

- Weekly programming.
- Multifunction: modes, temperatures.
- Eco mode.
- Configure, set and display operating parameters.
- Several languages.

- Can work as a thermostat.
- On-screen error codes.

Compatibility: Entire Yutaki range.



## Wireless thermostat for second circuit

ATW-RTU-06

- Multifunction.
- Easy to install.
- To control the temperature of a second circuit.

Compatibility: Entire Yutaki range.



## KNX Interface

ATW-KNX-02

- Centralises the control.
- Allows the Yutaki range to be integrated in KNX home automation systems.

Compatibility: Entire Yutaki range.



## Modbus for Yutaki

ATW-MBS-02

- Centralises the control.
- Allows the Yutaki range to be integrated in Modbus systems.

Compatibility: Entire Yutaki range.

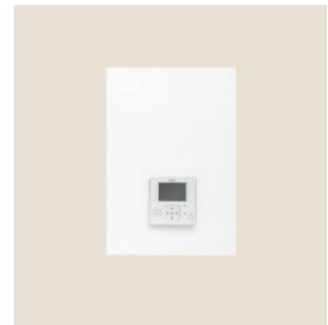

## Cascade control

ATW-YCC-01

- Suitable for high power installations.
- Centralised control of up to 8 Yutaki units.
- Different control options: cascade, rotary, smart defrost...

Compatibility: The entire Yutaki range except for Yutaki T.



**Wi-Fi adapter for Hi-Kumo app**

ATW-TAG-02

- Connect the Yutaki range using the Hi-Kumo app in order to manage it from any mobile device.
- Requires Hi-Box AHP-SMB-01.



**Hi-Box Yutaki**

AHP-SMB-01

- Accessory for the ATW-TAG-02 Wi-Fi adapter.
- Ensures compatibility with the Hi-Kumo app, in order to manage the Yutaki system from any mobile device.

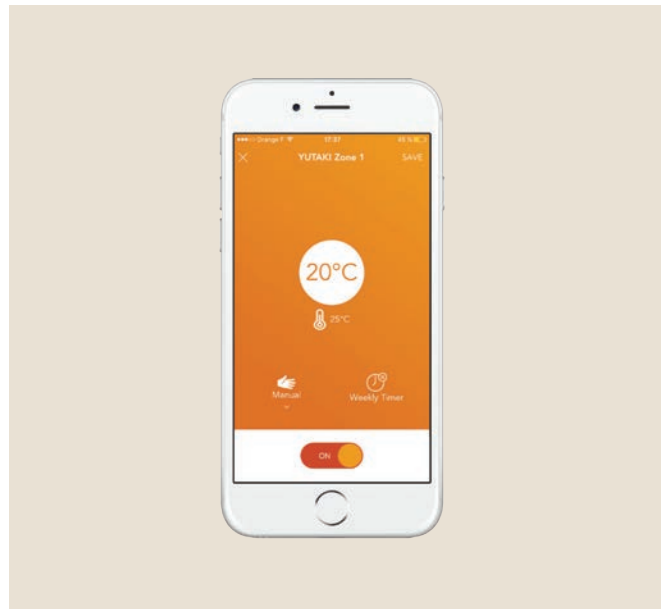

**How to enjoy Hi-Kumo**

1. Connect the Hi-Box to the router and the adapter to the Yutaki.
2. Download the app to your smartphone, tablet or computer.
3. Configure by simply searching for connected units and pairing them with the app.

# Accessories

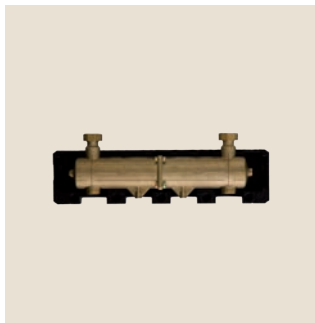

**Hydraulic separator**

ATW-HSK-01

- Non-corrosive (brass).
- 4 connection paths.
- With insulation.

Compatibility: Entire Yutaki range.



**Second temperature kit**

ATW-2TK-06

- Incorporated into 200 L hot water tank.

Compatibility: Yutaki S Combi with 200 L hot water tank.

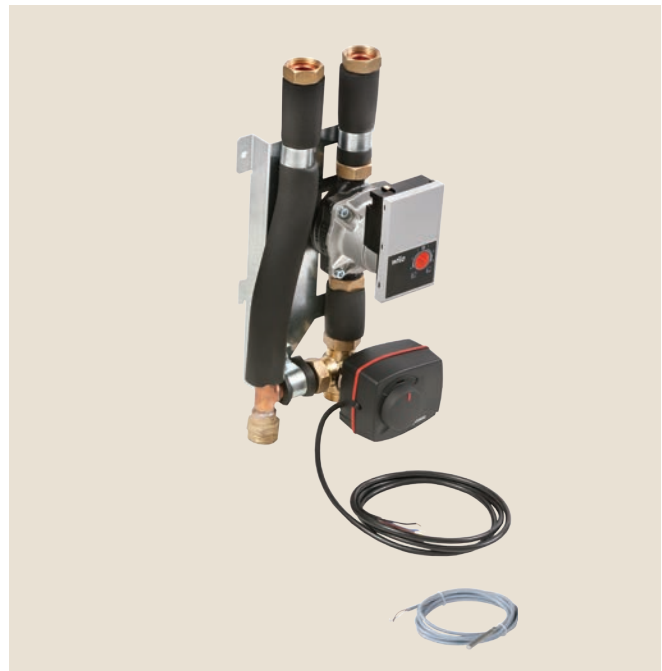

**Second temperature kit**

ATW-2TK-07

- Wall-mounted model.

Compatibility: Entire Yutaki range.

# Accessories



## Safety aquastat

ATW-AQT-01

- Recommended for underfloor heating applications.

Compatibility: Entire Yutaki range.



## 3-way valve

ATW-3WV-01

- Valve to allow operation in heating/hot water.

Compatibility: Entire Yutaki range.



## Proportional discharge valve

ATW-DPOV-01

- Proportional for variable flow installations.
- Included as standard in UK version tanks.

Compatibility: Entire Yutaki range.



## Second outdoor ambient temperature sensor

ATW-2OS-02

- Used to measure outside temperatures in the area where the outdoor unit is installed.

Compatibility: Entire Yutaki range.



## Wired wall-mounted sensor for indoor ambient temperature

ATW-ITS-01

Compatibility: Entire Yutaki range.



## Universal water temperature sensor

ATW-WTS-02Y

Compatibility: Entire Yutaki range.



## Backup heating element

WEH-6E

- 6 kW single/three phase.
- 3 x 2 kW stages.
- Built-in power relay.
- Steel body with external insulation.

Compatibility: Yutaki S80, Yutaki M.



## Unit controller cover

ATW-FCP-01

- Used to cover the gap left in the indoor unit when removing the programmer control and using it as a thermostat in any area.

Compatibility: Entire Yutaki range.



**Mirror box**  
ATW-YMM-01

– Simplifies installation when the Yutaki M is far from the property, avoiding the need to install large cable runs, using just two communication cables.

Compatibility: Yutaki M.



**Auxiliary output signal box**  
ATW-AOS-02

– Relay box for additional output signals.

Compatibility: Entire Yutaki range.



**Yutaki Range Cooling Kit**  
ATW-CKS-01/ATW-CKS-02/ATW-CKS-03/ATW-CKSC-01/ATW-CKM-01

– Used to switch the Yutaki range to work in both heat and cold.

ATW-CKS-01 (Yukaki S 2-3HP):  
ATW-CKS-02 (Yukaki S 4-6HP):  
ATW-CKS-03 (Yukaki S 8-10HP):  
ATW-CKSC-01 (Yukaki S Combi):  
ATW-CKM-01 (Yukaki M):  
Compatibility: The entire range except for Yutaki S80.



**Domestic hot water tank 200/300 L**  
DHWT-200/300 S-3.0H2E

Compatibility: Yutaki S, Yutaki S80, Yutaki M.

Hitachi tanks not currently available in the UK. G3 compliant Kingspan DHW cylinders are optional - speak to your Hitachi area sales manager or distributor for details.

## Hot water tanks

			DHWT200S-3.0H2E	DHWT300S-3.0H2E
Water accumulator	Volume	L	200	300
	Maximum temperature	°C	75	75
	Maximum pressure	bar	10	10
Water heat exchanger	Maximum coil temperature	°C	99	99
	Maximum coil pressure	bar	10	10
	Exchanger surface	m <sup>2</sup>	1.4	1.8
Type of insulation	Polyurethane	mm	50	50
Auxiliary heating element	Power	kW	3	3
Hydraulic connection	In DHW	inches	3/4 (f)	3/4 (f)
	Out DHW	inches	3/4 (f)	3/4 (f)
	Recirculation DHW	inches	3/4 (f)	3/4 (f)
	In coil water	inches	3/4 (f)	3/4 (f)
	Out coil water	inches	3/4 (f)	3/4 (f)
Accessories	Thermometer		Yes	Yes
	Safety thermostat		Yes	Yes



**Domestic hot water tank 200 and 260 L**  
DHWS200/260 S-2.7H2E

Compatibility: Yutaki S80.

			DHWS200S-2.7H2E	DHWS260S-2.7H2E
Power			1 ~ 230 V 50 Hz	1 ~ 230 V 50 Hz
Dimensions	Separate tank height (Built-in tank height)	mm	1282 (1980) *	1591 (2289) *
	Width	mm	600	600
	Depth (with connections)	mm	648 (675)	648 (675)
Weight		kg	62	81
Net capacity		L	200	260
Maximum operating temperature			75	75
Pipe diameter	Water input	inches	G 3/4 male	G 3/4 male
	Water output	inches	G 3/4 male	G 3/4 male
Wired control			PC-ARFHE	PC-ARFHE

Hot water tank shown is not currently available in the UK

# New R32 models



## Yutaki S RWM-2.0~3.0NRE

2.0 | 2.5 | 3.0 HP

Environmentally friendly refrigerant within a versatile heat pump range

### Widest range on the market:

– From 4.3 to 24kW and three new R32 models

### Top class performances:

– Best COP of the market up to 5.25

### High seasonal efficiency:

– A+++ for R32 models



**R32**  
REFRIGERANT

## Yutaki S Combi RWD-2.0~3.0NRW(S)E-(200/260)S(-K)

2.0 | 2.5 | 3.0 HP

The all-in-one compact product and best seller of the heating range

### Best in class performances for new housing market:

– With three new R32 models

### High seasonal efficiency:

– A+++ for R32 models

### Operating range improved for R32 models

### Specific models:

– Solar version, standard version

### Advanced controls:

– Common to all Yutaki models



**R32**  
REFRIGERANT

## Yutaki M RASM-2~3VRE

2.0 | 3.0 HP

Plug and play solution requiring no indoor space

### Fully re-designed:

– New cabinet for R32 models

### High seasonal efficiency:

– A+++ for R32 models

### Operating range improved for R32 models

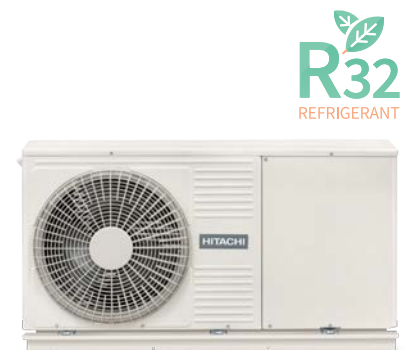

**R32**  
REFRIGERANT



# Hi-Kumo Pro

Web based platform for remote maintenance allowing to:

- Consult remotely the operational data of an Hitachi product
- Diagnosis a product online in case of failure

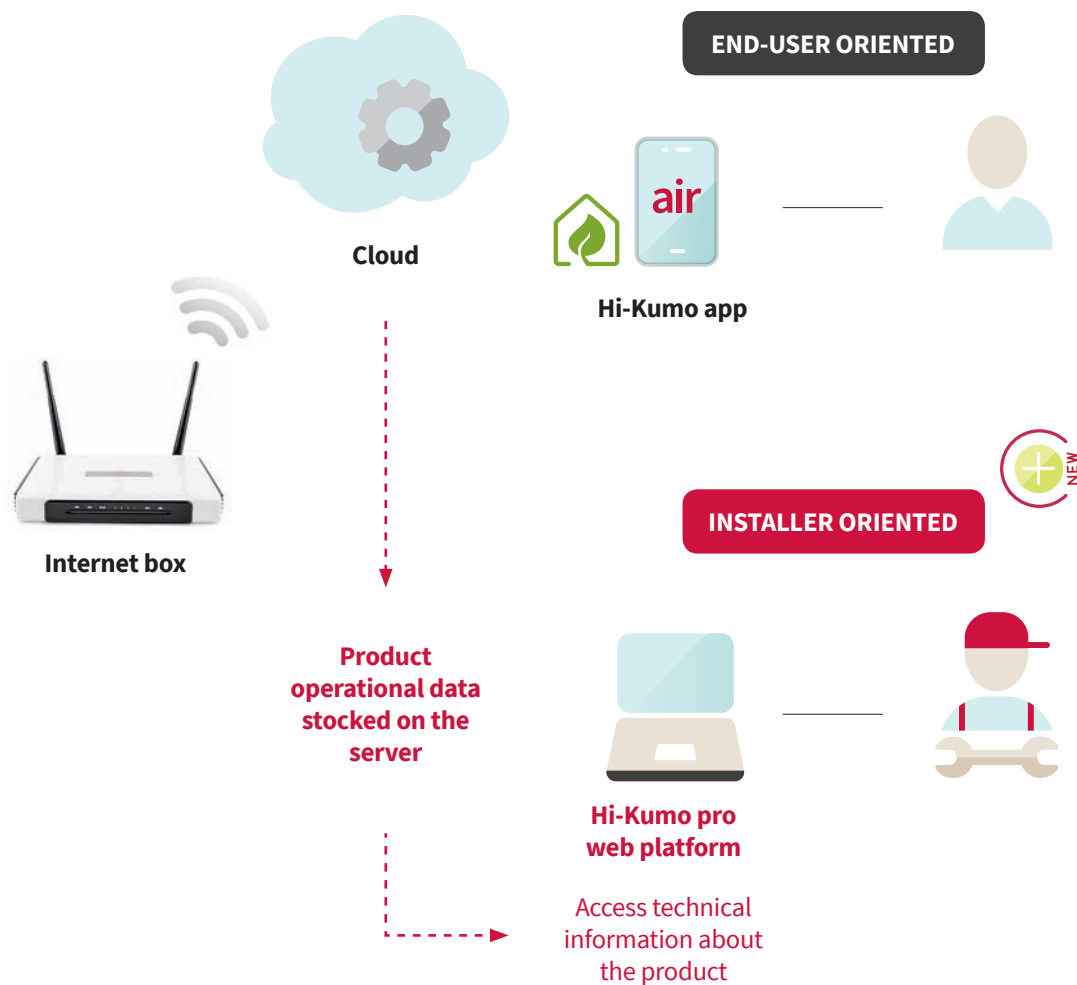

The first diagnostic can be done remotely ▶▶▶ Reduce costs

Direct access to **alarm code description**

Direct access to **instantaneous data**

Direct access to product **operational data** history

Quick access to **command buttons**

# IRE

## Regulations & incentives

Air to water heat pumps have become very popular in new build properties. This is because of stricter building regulations that discourage the use of fossil fuel boilers and encourage the take up of renewable energy heat solutions such as air to water heat pumps.



### New Government Grants

Up to  
**€3,500.00**  
government grant

With the introduction of a government grant of up to €3,500 (Introduced from April 2018) which is to replace inefficient fossil fuel boilers, it is clear that the direction of how to heat homes in Ireland is changing to a more renewable heat solution.

The Yutaki range complies with Part L building regulations for heating and for hot water solutions, the Yutaki S Combi has been tested to EN 16147 as a packaged solution and therefore passes regulations for heating and hot water.



Yutaki also complies with the Energy Related Products (ErP) directive. For more information please contact us.

**Call us on:** + 44 (0)203 901 0912 - Business hours: Mon - Fri 9am - 5pm, or  
**Email:** [aircon.ireland@jci-hitachi.com](mailto:aircon.ireland@jci-hitachi.com)

For more information on Yutaki, please visit [www.hitachi-hvac.co.uk](http://www.hitachi-hvac.co.uk) or for any schematics, please visit [www.yutaki-applications.com](http://www.yutaki-applications.com) and for product selection software, please visit [www.hitachi-hitoolkit.com](http://www.hitachi-hitoolkit.com)

All information correct at time of printing.

# UK

## Regulations & incentives

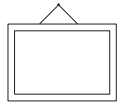

### Renewable Heat Incentive (RHI):

The government launched the Domestic RHI scheme on 9th April 2014. In summary, the scheme was set up to displace existing fossil fuel boilers with a renewable energy heat source such as air to water heat pumps like Yutaki.

Since its inception, the tariff for air to water heat pumps has increased meaning for each kW/hr that the Yutaki unit generates, the owner of the unit gets paid a “deemed” amount each quarter for a duration of seven years which is administered by Ofgem.

The process starts with the obtaining of an Energy Performance Certificate (EPC) which determines the total heat demand for the property. This figure is what is used to calculate the RHI payment and this is why it is “deemed”, unless for a more complicated installation such as a bivalent or hybrid system where the heat from the heat pump needs to be measured.

Total RHI payment over 7 years  
**£8,429.94**  
 assuming 1% inflation

The efficiency of the heat pump affects the amount paid. Please see example below of a standard property:

<b>Total Heat Demand</b>	14,805 kW/hrs
<b>Heat Pump installed</b>	RASM4.0VNE (11kW Yutaki M)
<b>Design Flow Temperature</b>	45°C
<b>Tariff</b>	10.49p/kW/hr



To ensure qualification of the RHI scheme, the product and the installer need to be Microgeneration Certification Scheme (MCS) approved. The entire Yutaki range is MCS approved, so it qualifies for the RHI incentive.



Yutaki also complies with the Energy Related Products (ErP) directive. For more information please contact us.

**Call us on:** + 44 (0)203 901 0912 - Business hours: Mon - Fri 9am - 5pm, or  
**Email:** [aircon.uk@jci-hitachi.com](mailto:aircon.uk@jci-hitachi.com)

For more information on Yutaki, please visit [www.hitachi-hvac.co.uk](http://www.hitachi-hvac.co.uk) or for any schematics, please visit [www.yutaki-applications.com](http://www.yutaki-applications.com) and for product selection software, please visit [www.hitachi-hitoolkit.com](http://www.hitachi-hitoolkit.com)

All information correct at time of printing.



## Hitachi Air Conditioning Europe SAS

Building 7, Foundation Park  
Roxborough Way  
Maidenhead  
Berkshire  
SL6 3UD  
United Kingdom

Email: [aircon.UK@jci-hitachi.com](mailto:aircon.UK@jci-hitachi.com)

Tel.: 020 3901 0912

### HITACHI. CERTIFIED QUALITY



[hitachi-hvac.co.uk](http://hitachi-hvac.co.uk)

The specifications of this catalogue may change without prior notice to allow Hitachi Cooling & Heating to incorporate the latest innovations for its customers. The information contained in this catalogue is merely informative. Hitachi Cooling & Heating declines any responsibility in the broadest sense, for damage, direct or indirect, arising from the use and / or interpretation of the recommendations in this catalogue.